



**Gesellschaft für Anlagen-
und Reaktorsicherheit
(GRS) mbH**

Assessment of the long-term safety of repositories

Scientific basis



**Gesellschaft für Anlagen-
und Reaktorsicherheit
(GRS) mbH**

Assessment of the long-term safety of repositories

Scientific basis

Ulrich Noseck
Dirk Becker
Christine Fahrenholz
Eckhard Fein
Judith Flügge
Klaus-Peter Kröhn
Jörg Mönig
Ingo Müller-Lyda
Tilman Rothfuchs
André Rübel
Jens Wolf

December 2008

Remark:

This report, with the German title „Wissenschaftliche Grundlagen zum Nachweis der Langzeitsicherheit von Endlagern (Kurztitel WiGru)“, was prepared under the contract No. 02 E 9954 with the Federal Ministry of Economics and Technology (BMWi).

The work was conducted by the Gesellschaft für Anlagen- und Reaktorsicherheit (GRS) mbH.

The authors are responsible for the content of this report.

**GRS - 237
ISBN 978-3-939355-11-3**

Keywords:

performance assessment, radionuclide transport, repository, safety case, safety indicator

Preface

The assessment of the long-term safety of a repository for radioactive or hazardous waste requires a comprehensive system understanding and capable and qualified numerical tools. All relevant processes which contribute to mobilisation and release of contaminants from the repository, transport through the host rock and adjacent rock formations as well as exposition in the biosphere have to be implemented in the programme package. The objective of the project “Scientific basis for the assessment of the long-term safety of repositories”, identification number 02 E 9954, was to follow national and international developments in this area, to evaluate research projects, which contribute to knowledge, model approaches and data, and to perform specific investigations to improve the methodologies of the long-term safety assessment.

This project, founded by the German Federal Ministry of Economics and Technology (BMWi), was performed in the period from 1st November 2004 to 31st July 2008. The results of the key topics investigated within the project are published in the following reports:

GRS-report 222: About the role of vapour transport during bentonite resaturation

GRS-report 238: Elemente eines Safety Case zur Realisierung eines Endlagers in Deutschland

GRS-report 239: Chemical effects in the near field of a HLW repository in rock salt

GRS-report 240: Safety and Performance indicators for repositories in clay and salt formations

GRS-report 241: Impact of climate change on far-field and biosphere processes for HLW repositories in rock salt

GRS-report 242: Gase in Endlagern im Salz

The results of the whole project are summarised in the overall final report:

GRS-report 237: Scientific basis for the assessment of the long-term safety of repositories

Contents

1	Introduction.....	1
2	Methodologies and the safety case.....	3
2.1	International status of the safety case.....	3
2.2	Safety and Performance indicators	9
2.2.1	Safety indicators	11
2.2.1.1	Safety indicators in salt formations	12
2.2.1.2	Safety indicators in clay formations.....	13
2.2.2	Performance indicators.....	14
2.2.2.1	Performance indicators in salt formations	14
2.2.2.2	Performance indicators in clay formations.....	17
2.3	German Safety Requirements.....	18
2.4	Natural Analogues	19
2.4.1	Natural analogues for the long-term scale.....	22
2.4.2	Analogues for the early post-closure phase	25
2.5	Scenario development	27
2.5.1	Human action scenarios from international studies	27
2.5.2	The French Dossier 2005 Argile	28
2.5.3	The Swiss Opalinus Clay Study	29
2.5.4	The Swedish SR–Can Study	30
2.5.4.1	Human intrusion - the deep borehole scenario.....	30
2.5.4.2	Human action scenarios - excavation of a rock cavity or a tunnel	33
2.5.5	The Belgian SAFIR 2 Study	34
2.5.5.1	The exploitation drilling scenario.....	35
2.5.5.2	The Exploratory drilling scenario.....	37
2.5.6	The BfS-Study on Conceptual and safety-related issues regarding the disposal of radioactive wastes	37
2.5.7	Results from the German scenario working group	41

3	International developments	45
3.1	OECD/NEA RWMC	45
3.1.1	Recent international developments	45
3.1.1.1	Research and development	45
3.1.2	Recent Documents	47
3.1.3	Country Reports.....	48
3.2	IGSC.....	48
3.2.1	Core Activities.....	48
3.2.2	Technical Activities	49
3.2.3	Co-operative Projects	50
3.2.4	Future Work.....	51
3.3	AMIGO	55
3.3.1	Building confidence using multiple lines of evidence.....	56
3.3.2	Communication and management	57
3.3.3	Handling of uncertainty	58
3.3.4	Iteration between safety strategy, design and site characterisation.....	59
3.4	NEA-Working Group Timing of High-level Waste Disposal	60
3.5	NEA Sorption project	65
3.6	Clay-Club.....	66
3.7	FUNMIG	70
4	Selected topics	75
4.1	Safety analyses for Clay formations.....	75
4.1.1	Gas generation and transport	75
4.1.1.1	Gas generation	76
4.1.1.2	Gas transport in clay formations	78
4.1.1.3	Gas transport in the engineered barrier system	95
4.1.1.4	Conclusions	98
4.1.2	Excavation disturbed zone.....	100
4.1.2.1	Definitions.....	100
4.1.2.2	Creating of an EDZ.....	101
4.1.2.3	Evolution of the EDZ.....	115

4.1.2.4	Performance assessment aspects	121
4.1.2.5	Summary and Conclusions	123
4.2	Geochemical effects	126
4.2.1	Treatment of C-14 in spent fuel performance assessment	126
4.2.2	Impact of uncertainties in geochemical effects on long-term safety assessment	133
4.3	Gas workshop.....	138
4.3.1	Gas generation	139
4.3.2	Potential disturbances of the barrier integrity	140
4.3.3	Potential disturbances of the integrity of seals	140
4.3.4	Transport of gases in the repository mine	141
4.3.5	Impact of gases on the chemical milieu of the near-field.....	142
4.3.6	Transport of gases in the far field.....	142
4.4	Impact of climatic changes.....	143
4.5	New aspects of bentonite saturation – EBS Taskforce.....	152
4.5.1	Task Force on EBS.....	152
4.5.1.1	THM-modelling of bentonite re-saturation	153
4.5.1.2	Modelling gas flow through fully saturated bentonite.....	155
4.5.2	Advancement of the vapour flow model	156
4.5.2.1	Verification of the vapour flow model of GRS.....	156
4.5.2.2	Steady-state conditions.....	161
4.5.2.3	Possible further investigations	163
5	Summary	165
6	References	171
	List of Figures.....	185
	List of Tables	190

1 Introduction

The assessment of the long-term safety of a repository for radioactive waste requires a comprehensive system understanding and a qualified and powerful programme package. The models of this integrated tool need to consider the relevant processes, which play a role for mobilisation and release of radionuclides from the near field of a repository, for transport through the host rock and adjacent formations and for the exposition in the biosphere.

During the last ten years on the international level the concept of the safety case has been developed. According to NEA a safety case is the synthesis of evidence, analyses and arguments that quantify and substantiate a claim that the repository will be safe after closure and beyond the time when active control of the facility can be relied on /NEA 04a/. One important aspect of the safety case is that the robustness of the long-term safety assessment is strengthened by the use of multiple lines of evidence leading to complementary also qualitative safety arguments that can compensate for shortcomings in any single argument. Therefore, an important aspect of the project was to follow the international developments and to analyse and document the elements of a safety case, to comprise arguments to be used as multiple lines of reasoning, like information from natural analogues, and investigation of safety and performance indicators in addition to dose.

Beside salt formations, where the main focus of research for deep disposal of nuclear waste repositories has been in Germany, also clay formations are currently considered as a potential repository for high level waste. New programmes for an integrated safety assessment of a HLW repository in indurated clay have been developed recently and a first safety assessment study was performed /RUE 07/. For a complete safety case for such a repository additional processes and scenarios like gas transport or impact of an excavation disturbed zone on the radionuclide release and transport have to be considered.

The R&D work within this project has contributed to increase the system understanding for performing a long-term safety assessment and building a safety case for a radioactive waste repository.

In particular, the project focussed on the following selected topics:

- Based on international developments in particular on recently developed safety cases from other countries all elements of a safety case have been compiled and illustrated. It has been discussed, which elements are available for a safety case for a potential German repository in rock salt.
- For repositories in rock salt and clay formations several safety and performance indicators have been proposed and tested by re-calculation of selected scenarios of recent safety assessment studies for HLW repositories in both formations.
- National and international R&D work with respect to specific processes in clay formations, like gas transport or properties and behaviour of the excavation disturbed zone have been compiled and evaluated. The aim was to state the current knowledge and to propose how these processes might be tackled in an integrated safety assessment for a HLW repository in a clay formation.
- The work on the development of an alternative model to describe the bentonite re-saturation was continued. Emphasis was put on the treatment of non-isothermal processes, as they are expected in a repository. Test cases from the EBS task-force were simulated and results discussed on the periodic meetings.
- Uncertainties in geochemical effects for a repository in salt formations have been evaluated. In particular the impact of new source terms for vitrified high level waste and spent fuel as well as solubility limits of selected radionuclides on the radionuclide release and potential radiation exposure have been analysed.
- The impact of future changes in climatic conditions on flow and transport processes in the overburden of a repository in rock salt and on the boundary conditions and exposition pathways in the biosphere was investigated.

2 Methodologies and the safety case

On the international level the concept of the safety case was developed and already applied within the repository programmes of some countries during the last decade.

2.1 International status of the safety case

Within this study the work performed by international organisations OECD/NEA and IAEA as well as safety cases from other countries have been compiled and evaluated with regard to elements, components and further potential aspects for realisation of a HLW repository in rock salt in Germany. In the following some major aspects are summarised; a detailed description can be found in /MUE 08/.

According to the IAEA and NEA “the safety case is an integration of arguments and evidence that describe, quantify and substantiate the safety and the level of confidence in the safety, of the geological facility” /IAE 03/, /NEA 04a/. More advanced is the definition in /IAE 06/. “The safety case substantiates the safety, and contributes to confidence in the safety, of the geological disposal facility. The safety case is an essential input to all the important decisions concerning the facility. It includes the output of safety assessments (see below), together with additional information, including supporting evidence and reasoning on the robustness and reliability of the facility, its design, the design logic, and the quality of safety assessments and underlying assumptions. The safety case may also include more general arguments relating to the need for the disposal of radioactive waste, and information to put the results of the safety assessments into perspective. Any unresolved issues at any step in the development, operation and closure of the facility will be acknowledged in the safety case and guidance for work to resolve these issues will be provided.” Accordingly, the safety case also comprises all safety relevant aspects of the operational phase.

Fig. 1 summarises schematically the content and structure of the safety case. It consists of the safety case for the operational phase and the post-closure phase. Only the latter one was considered in detail within this work. The safety case for the post closure phase can be structured in safety assessments and multiple lines of arguments/multiple lines of evidence. The central component of the safety assessments is the long-term safety assessment, which results need to be underpinned in the safety case with statements on the robustness and reliability.

Beside this, other specific assessments, like the demonstration that criticality cannot occur in the repository, belong to the safety assessments. This definition of the safety case forms the basis of the work performed within this task. The work was restricted on the post-closure safety case.

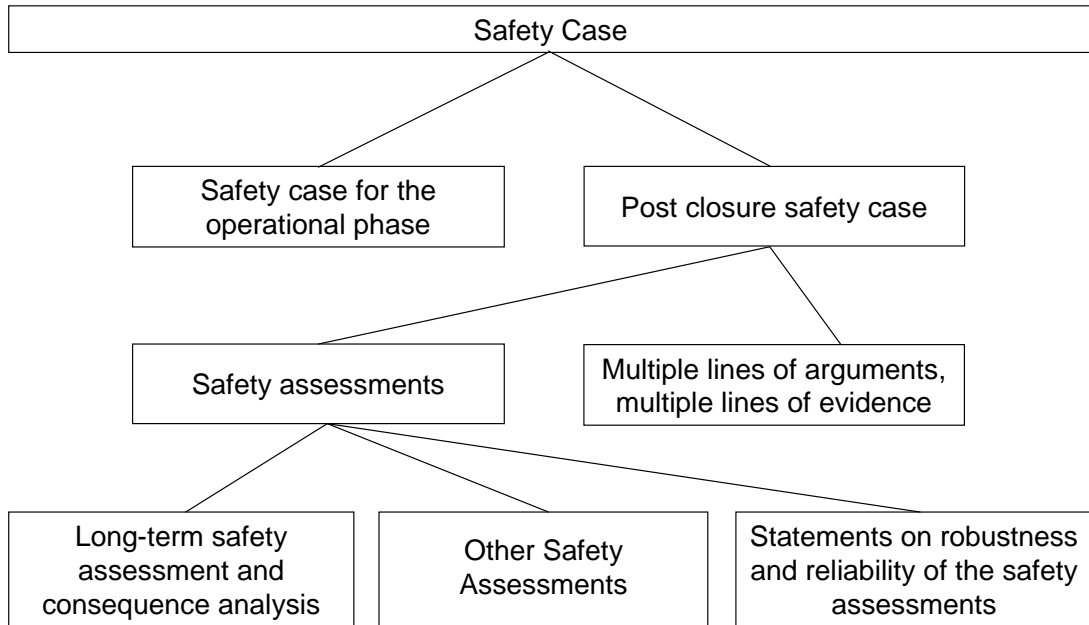

Fig. 1 Correlation of safety case, safety assessments, long-term safety assessment and additional elements of the safety case.

According to NEA the presentation of the safety case for the implementing process of a repository should consist of a structured set of documents, containing five elements with a number of associated components /NEA 04a/. The elements, components and associated aspects are listed in Tab. 1. It should be considered that, depending on the status of the safety case, several components might only briefly or generically be described.

Tab. 1 Elements (E), components (K) and potential associated aspects of a safety case for a geological repository (after /NEA 08b/)

E₁		“Purpose and context”: Description of the purpose (normally a decision or a license) and context (e.g. construction of an exploration mine)
	K_{1.1}	The objective or objectives, to be achieved by the safety case
	K_{1.2}	All measures necessary for achievement of the objectives and implementation
	K_{1.3}	All advantages and disadvantages resulting from the project
	K_{1.4}	Current status of the project and further project works, facilitated by a positive decision
E₂		“Safety strategy”
	K_{2.1}	<i>Management strategy:</i> Overall strategy of the various activities required for repository planning, implementation and closure, including siting and design, safety assessment, site and waste form characterisation and R&D. <ul style="list-style-type: none"> - Development of a safety culture by the implementer - Efficiency of integration of information and knowledge coming from the different fields of the programme (site characterisation, design, R&D, assessments, waste characterisation, etc.) - Preservation of information and data - Rationale behind the step-wise approach - To what extent is flexibility built into the overall project plan - Implementation of a quality assurance (QA) system at the implementer and all other contributing organisations - Measures for selection of external experts to ensure suitable qualification and responsibility for the decisions they made - Application of the concept of best available techniques (BAT) - Zusammenhang mit Abfallcharakterisierung und Annahmebedingungen
	K_{2.2}	<i>Siting and design strategy:</i> Commitment, how an appropriate site is selected according to the selection criteria and development of practical engineering solutions, consistent with the characteristics of the selected site and the waste forms. <ul style="list-style-type: none"> - Description of established / developed site selection criteria, guidelines and procedures to ensure that the repository system is robust in terms of long-term safety - Other siting and design principles that are relevant for the safety case, e.g. with respect to retrievability or monitoring - Description of waste conditioning, waste acceptance and disposal conditions

	K _{2.3}	<p><i>Assessment strategy:</i></p> <ol style="list-style-type: none"> 1. Definition of the assessments to be performed, the approach to evaluate evidence and how potential evolutions of the system have to be analysed; 2. Identification and evaluation of uncertainties and approach to reduce their relevance (Reduction of lack of knowledge by initiation of research projects, by site selection or by siting and design, and construction investment) <ul style="list-style-type: none"> - Strategy for the management and treatment of uncertainty in the assessments, evtl. treatment of different timescales - Application of probabilistic or deterministic approaches for the long-term safety assessment - Criteria or procedures for exclusion of FEPs or parameter combinations in scenario development - Scenario „Human Intrusion“: Selection and analysis, exclusion of the risk of the intruder, reason for separate treatment - Rationale for the use of conservative model assumptions or pessimistic parameters to uncertainties - Sensitivity analyses - Alternative conceptual models - „Stylised Approaches“ - What-if?-scenarios - Rationale behind cut-off times for calculations of dose and/or risk, overall timescale of concern in developing the safety case - Strategy for inclusion of possibly contradictory opinions of technical experts
E ₃		“Assessment basis”
	K _{3.1}	<p>System concept: Description of the disposal system, its components and their safety functions</p> <ul style="list-style-type: none"> - Role and relevance to safety of each component of the disposal system, Distinction between multi-barrier principle or safety functions - Multiple lines of arguments for the adequacy of scientific understanding of the key features of the disposal system
	K _{3.2}	<p><i>Scientific and technical information and understanding :</i></p> <p>presentation of all safety relevant scientific and technical data</p> <ul style="list-style-type: none"> - Parameter values, its uncertainties and variation over time. - Evidence that the information base is consistent - Measures to ensure that all relevant scientific information is taken into account and no significant FEPs have been overlooked

	K _{3.3}	<p><i>Methods, -models, computer codes and databases for the analysis of the system performance</i></p> <ul style="list-style-type: none"> - Process for handling of scientific understanding to obtain accurate models and databases that will support the safety case - Source of the waste/radionuclide inventory, underlying assumptions and uncertainties - Types of evidence that support the applicability of models and associated databases (laboratory and field measurements, observations at various scales, natural analogues) - Utilization of data, results and technical guidance from international sources (e.g. FEPs and thermodynamic database) or other national programmes - Impact of the duration and nature of the construction and operational period on the post-closure safety assessment - What roles do detailed mechanistic models of specific processes or combinations of processes play in the safety case (e.g. models for gas formation, convergence, surface complexation)
E ₄		“Evidence, analyses and arguments”
	K _{4.1}	<p><i>General evidence for the strength of geological disposal as a waste management option</i></p> <ul style="list-style-type: none"> - Description of the isolation potential of respective rock formations - Observations of natural systems - Evaluation of alternative waste management options like transmutation or permanent interim storage at surface facilities
	K _{4.2}	<i>Evidence of the intrinsic quality of the site and design</i>
	K _{4.3}	<p>„<i>Consequence analysis</i>” as part of the conventional long-term safety analysis, where the impact on the subject of protection for the considered scenarios is quantified and compared with the acceptance level.</p> <ul style="list-style-type: none"> - Description of scenarios, probabilistic realisations or assessment cases giving rise to doses and/or risks above acceptance limits and arguments to counter these unfavourable findings - Evaluation of reliability and plausibility of the results of key assessment calculations
	K _{4.4}	<p>Increase of „<i>robustness</i>”</p> <ul style="list-style-type: none"> - Description of alternative safety and performance indicators complementary to dose and risk and measures which they can be compared to judge safety - Additional complementary evidence and lines of arguments to support the final conclusions or recommendations of the safety case

	K_{4.5}	Arguments for the adequacy of the strategy to manage <ul style="list-style-type: none"> - uncertainties - open questions
E₅		“Synthesis of the safety case”
	K_{5.1}	<i>Description of key findings and statements</i> <ul style="list-style-type: none"> - Description, how all relevant data and information have been considered, all models have been adequately tested and a rationale assessment procedure has been followed; - Consideration of limitations of currently available evidence, arguments and analyses and highlighting the principle grounds for the judgement that the development of the disposal system can successfully be finalised - Description and rationale of necessary investigations and operations for the next step in the repository programme
	K_{5.2}	“Statement of confidence” as explicit statement of the implementer <ul style="list-style-type: none"> - in adequate confidence in the possibility of achieving a safe repository, - that the repository will fulfill all safety requirements and - that the objective of construction of a safe repository can be achieved and the applied license or decision is justified

Each of these components and aspects is described in detail in /MUE 08/ and various examples from national studies of other countries with advanced programmes – especially from recent studies from NAGRA, Andra, SKB, and POSIVA – have been used to illustrate it.

Finally, elements and components of a safety case for the implementation of a HLW repository in rock salt have been compiled. This compilation is not complete and has to be considered as a first step. A more comprehensive evaluation is currently performed within the R&D project ISIBEL /BUH 08a/. Major emphasis was put in those components which can be used as multiple lines of reasoning for the long-term safety of the repository. In particular those arguments, which underpin the understanding of the key properties of the repository system, have been discussed. For the repository in rock salt a key property is the viscoplastic behaviour of rock salt and the accompanying convergence, which leads to the closure of voids and other potential flow pathways for fluids in the normal evolution. Accordingly, multiple lines of arguments contributing to a deeper understanding of these for the isolation of the waste necessary properties and supporting the integrity of the salt dome over geological time frames have to be used in the safety case. Here, several observations from natural systems or technical analogues are available. A selection of such arguments is described in section 2.4.

The robustness of results from consequence calculations for altered evolution scenarios might be increased by the application of complementary safety indicators to the dose and performance indicators. First experiences for the application of both kind of indicators for a repository in rock salt are now available /WOL 08/ and are summarised in chapter 2.2.

2.2 Safety and Performance indicators

As discussed above, one type of evidence and arguments in support of a safety case is the use of safety indicators complementary to dose and risk. Such complementary indicators can avoid to some extent the difficulties faced in evaluating and interpreting doses and risks. In particular the individual human behaviour as well as near-surface processes, which are the basis for calculation of dose and risk, are difficult to predict over long time scales. In contrast the possible evolutions of a well-chosen host rock can be bounded with reasonable confidence over much longer time scales, i.e. about one million years into the future. Hence, there is a trend in some recent safety cases towards evaluating, safety indicators in addition to dose and risk, like radiotoxicity fluxes from the geosphere, which do not rely on description of human behaviour and can support the statement of low consequences of any radionuclide release to the surface environment and increase the robustness of the safety case, e.g. /NAG 02a/.

The use of complementary safety indicators has also been widely discussed in international fora and projects, e.g. /IAE 94/, /IAE 03/, /BEC 03b/. It should be noted, that the terminology used with regard to indicators is not consistent among national programmes. Here it is referred to definitions of the SPIN and PAMINA project. In the frame of the SPIN project safety and performance indicators for radioactive waste repositories in crystalline formations were identified and their applicability tested by calculations for recent safety assessments /BEC 03b/.

Safety indicators provide conclusions about the safety of the total repository system, while performance indicators contribute to analysis of the performance of single barriers or sub-systems. The aim of the work presented here was to identify suitable safety and performance indicators for repositories in salt and clay formations. It is described in detail in /WOL 08/. First sets of three safety and three performance indicators for both host rocks have been derived and were successfully applied to

recent long-term safety calculations for high level waste repositories in salt /BUH 08a/ and clay /RUE 07/.

The three safety indicators considered are (i) the effective dose rate [Sv/a], (ii) the radiotoxicity concentration in the biosphere water [Sv/m³] and (iii) the radiotoxicity flux from the geosphere (overlying rock) [Sv/a]. For each safety indicator appropriate reference values were derived by determining natural background values and considering a safety margin by constraining the reference value to about one third of the natural background value. For the effective dose rate and the radiotoxicity concentration in the biosphere water two global reference values have been determined. The radiotoxicity flux from the geosphere required a local site-specific reference value. The general philosophy of this procedure was to keep the reference values comparatively low in order to enhance the confidence in the safety statement given by the corresponding safety indicator. For both case studies the following reference values were applied.

- for the effective dose rate: $1 \cdot 10^{-4}$ Sv/a,
- for the radiotoxicity concentration in the biosphere water: $2 \cdot 10^{-6}$ Sv/m³
- for the radiotoxicity flux from the geosphere: 0.1 Sv/a.

Additionally to the three safety indicators three performance indicators are identified and assessed for the repositories in salt and in clay. For the calculation of the performance indicators the repository system was divided into several compartments. The selection of the compartments depends on the host rock type and in particular on the repository concept and has a strong impact on the results.

The following performance indicators are considered (i) radiotoxicity inventory in different compartments [Sv], (ii) radiotoxicity fluxes from compartments [Sv/a] and (iii) integrated radiotoxicity fluxes from compartments [Sv].

For testing of the safety and performance indicators for a repository in rock salt two scenarios have been regarded:

- the combined failure of shaft and drift seals (so called first scenario) and
- brine inclusions inside the repository (so called second scenario).

For application to the repository in a clay formation the reference scenario was applied /RUE 07/.

In the following sections the results for the safety indicators and performance indicators are summarised. In both sections general results are discussed first, followed by the description of host rock specific results.

2.2.1 Safety indicators

The main advantage of a safety indicator is that this type of indicator is an objective measure for the safety of the whole repository system. A safety indicator allows a comparison with other repository systems.

Due to the independently derived corresponding reference values the three safety indicators provide three different safety statements. These safety statements are:

1. *Individual dose rate*: Human health is not jeopardised by radionuclides released from the repository. All biological effects to a human individual, i.e. the incorporation of radionuclides by humans via different exposition pathways remain so small that they have no impact on human health.
2. *Radiotoxicity concentration in the biosphere water*: The ingestion of the biosphere water that is contaminated with the radionuclide flux from the repository is as harmful as the ingestion of average drinking water provided in Germany (regarding the impact of radionuclides).
3. *Radiotoxicity flux from the geosphere (overlying rock)*: The radiotoxicity flux from the repository system to the groundwater is in the same order of magnitude as the present natural radiotoxicity flux in the groundwater.

The combination of the three indicators gives a strong argument for or against the safety of a repository system. The distinctive uncertainties of every single indicator are thus less important for the overall safety assessment.

2.2.1.1 Safety indicators in salt formations

The safety indicators are very close to the reference value in the first scenario “Failure of shaft and drift seals“, only the effective dose rate shows a small margin of about one order of magnitude (Fig. 2). Summarized, the investigation of the three safety indicators increases the confidence in the safety assessment.

For the second scenario the margin between the reference value and the calculated value is almost five orders of magnitude. For this scenario all three safety indicators match very well for both the temporal evolution and the absolute value. This provides a well-founded safety statement for the second scenario.

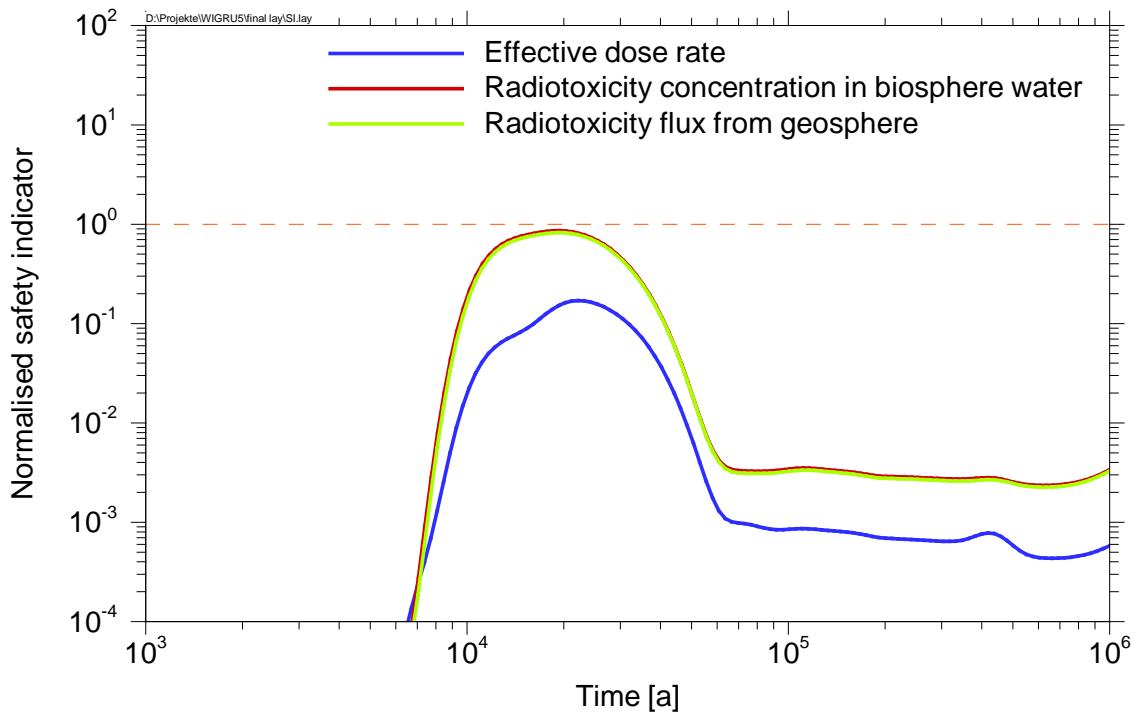

Fig. 2 Normalised safety indicators for repository in rock salt. Scenario: „Failure of shaft and drift seals“; normalized safety indicator of 1: reference value

This study is the first detailed calculation of a set of different safety indicators for a repository for HLW in a salt formation in Germany. The applied repository concept has a complex structure and reflects the current state of the art /BUH 08b/. It could be shown that the necessary tools for the calculation and evaluation of the proposed safety indicators are already available. In a next step a systematic sensitivity analysis should be performed for the different safety indicators. Since safety indicators in salt are always based on release scenarios, the determination of the scenario probabilities

is a decisive step in assessing the results. If scenario probabilities are available a further type of indicators, risk indicators, could be added to the safety assessment of repository systems.

2.2.1.2 Safety indicators in clay formations

The three safety indicators have also been successfully applied to long-term safety calculations for a repository in clay. The temporal evolution of the curves for the indicators shows a very similar shape (Fig. 3). The differences between the three curves are due to differences in weighing of the radionuclides C-14 and I-129 by the dose coefficients compared to the dose conversion factors. A very simple model was applied in this study regarding only the near field and the host rock formation, but no transport in other formations as adjacent low permeable formations or the aquifers in the overburden. This fact is the reason for the similar shape of the curves. A different shape of the three indicators curves would only be expected if an additional retention in the far field were considered in the model.

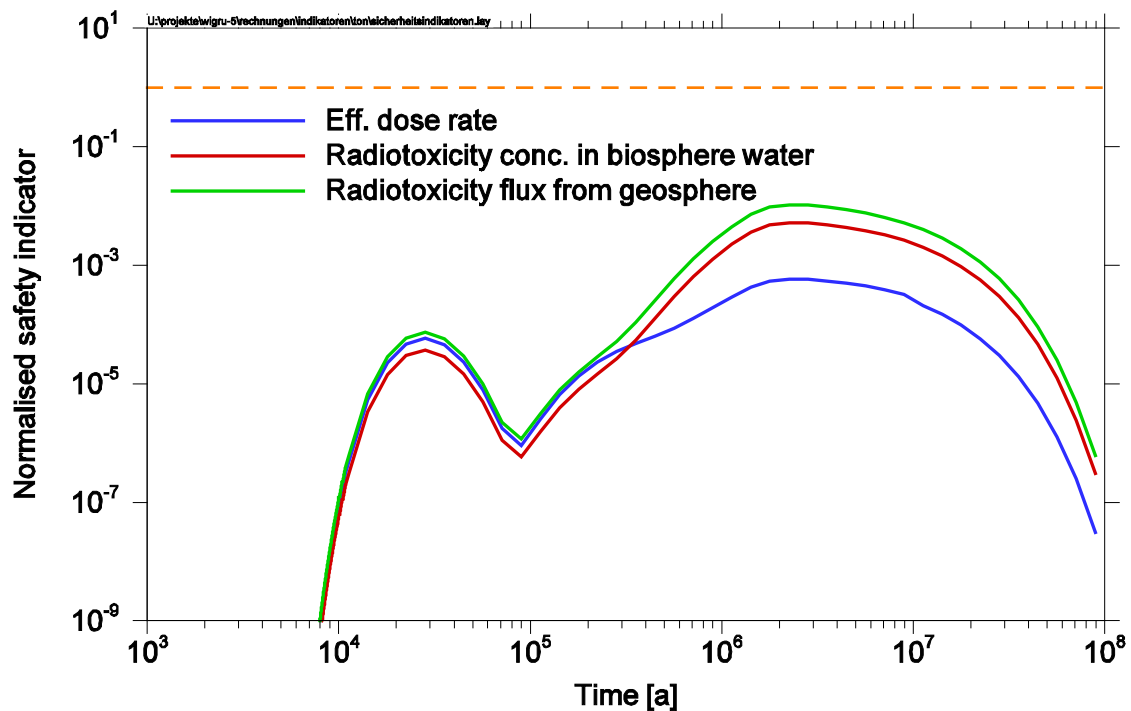

Fig. 3 Normalised safety indicators for the reference case for a repository in clay; normalized safety indicator of 1: reference value

The values of the three indicators relative to their respective reference value are also in the same range. Since the reference values were determined independently, all three indicators confirm about the same degree of safety for the different safety statements. Further testing of the safety indicators for a repository in clay formations with additional low permeable adjacent formations such as the lower Cretaceous Clay in Northern Germany will be performed in the future to better identify the use of and the differences between the three indicators.

2.2.2 Performance indicators

One important shortcoming of safety indicators is that they do not indicate which parts of the repository system (barriers or compartments) contribute to which extent to the overall safety. For that purpose performance indicators are applied in order to give further arguments regarding the safety of a repository system. Performance indicators aim at providing a measure of the level of quality, reliability or effectiveness of a given compartment of the whole system. In general performance indicators provide valuable additional information to the safety indicators. They are an important element in the decision-making process and they facilitate communication to the regulator and the public. They give additional valuable information on the repository system and thus increase the system understanding and they play an important role for the optimisation of the repository concept.

In contrast to the safety indicators the performance indicators are dependent on the repository concept. Especially the selection of compartments has a strong influence on the results.

2.2.2.1 Performance indicators in salt formations

The results show that a set of performance indicators is needed to get a better understanding for the important processes in a complex repository system in a rock salt formation. In general, the radiotoxicity inventories in the selected compartments and the corresponding fluxes between these compartments are good indicators for the evolution of the contaminant transport through the repository system. A partitioning of the repository into compartments was carried out in order to take into account the different sections. This partitioning helps for understanding of the investigated system. But the inventories and fluxes inside the repository need a lot of interpretation and

explanation and require a good knowledge about the repository system. For the compartments representing the structure of a repository (e.g. Fig. 4 and Fig. 5) it is difficult to interpret the radiotoxicity inventories, since flows inside and between the different compartments can compensate each other.

The most illustrative performance indicator is the integrated radiotoxicity flux from different compartments. If this indicator is compared with the initially emplaced radiotoxicity inventory, the performance of each compartment can be demonstrated in an illustrative way. An example is given in Fig. 4 and Fig. 5 for both scenarios; SF1 and SF2 represent different compartments containing spent fuel.

The total reduction of the radiotoxicity in the whole repository system is about nine orders of magnitude for the first scenario of the combined failure of shaft and drift seals and 13 orders of magnitude for the second scenario of brine inclusions inside the repository. In the second scenario the brine from the inclusions is immediately in contact with the waste of compartment 2, identified by instantaneous radiotoxicity flux of SF2 (Fig. 5). Thus, in this scenario the mobilisation of radionuclides is much higher and the radiotoxicity flux from the waste compartments is two orders of magnitude higher. But due to the intact geotechnical barriers the volume of brine inside the repository is small and the brine flow out of the inventory compartments is very low resulting in a reduced transport of radionuclides. As a consequence the radiotoxicity flux from the repository is much smaller compared to the first scenario. Compared to the geotechnical barriers the effect of the overlying rock is quite marginal, for the sum of all radionuclides the reduction factor is in both scenarios below 0.5.

Very useful is the additional analysis of single radionuclides. By comparing radionuclides with different characteristics (e.g. different solubility limits or sorption coefficients) additional processes or effects in the repository system can be studied and explained.

The proposed indicators fulfil the goal of providing a measure of the level of quality, reliability and effectiveness of a certain compartment in the presented repository system. They could be used to optimise the system, e.g. to change the arrangement of the different waste sections in the repository. If the repository system is changed, it could be necessary to test further indicators and add them to the proposed set.

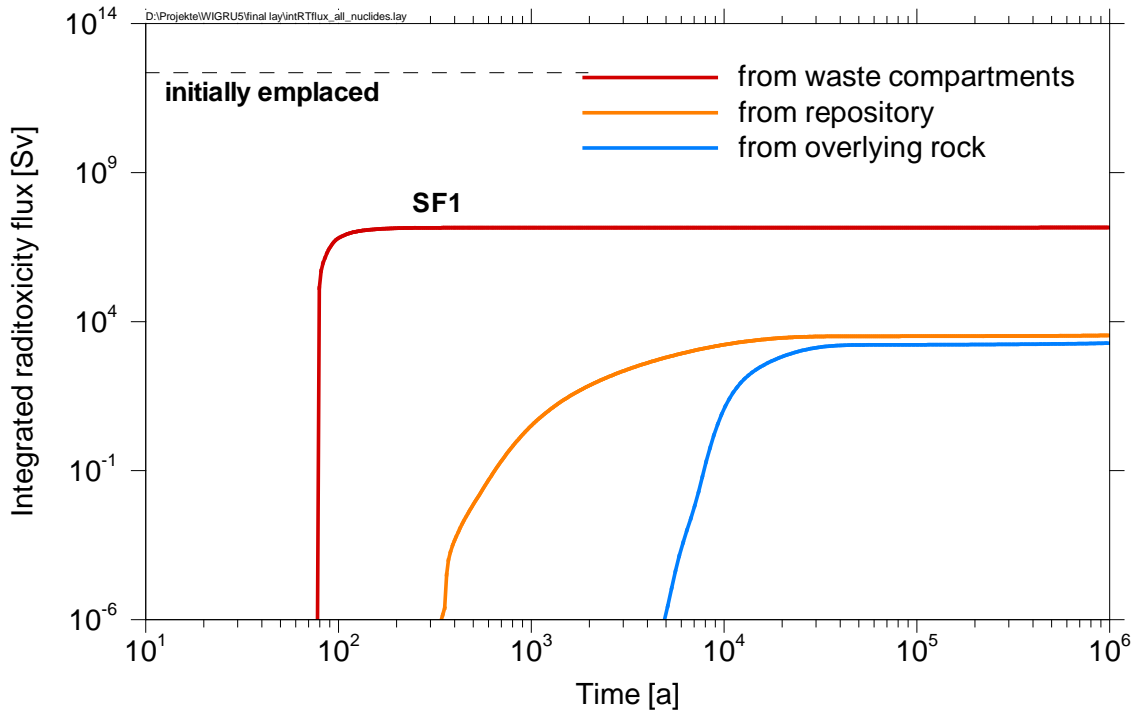

Fig. 4 Integrated radiotoxicity flux from different compartments for all radionuclides with initially employed radiotoxicity inventory for the combined failure of shaft and drift seals scenario

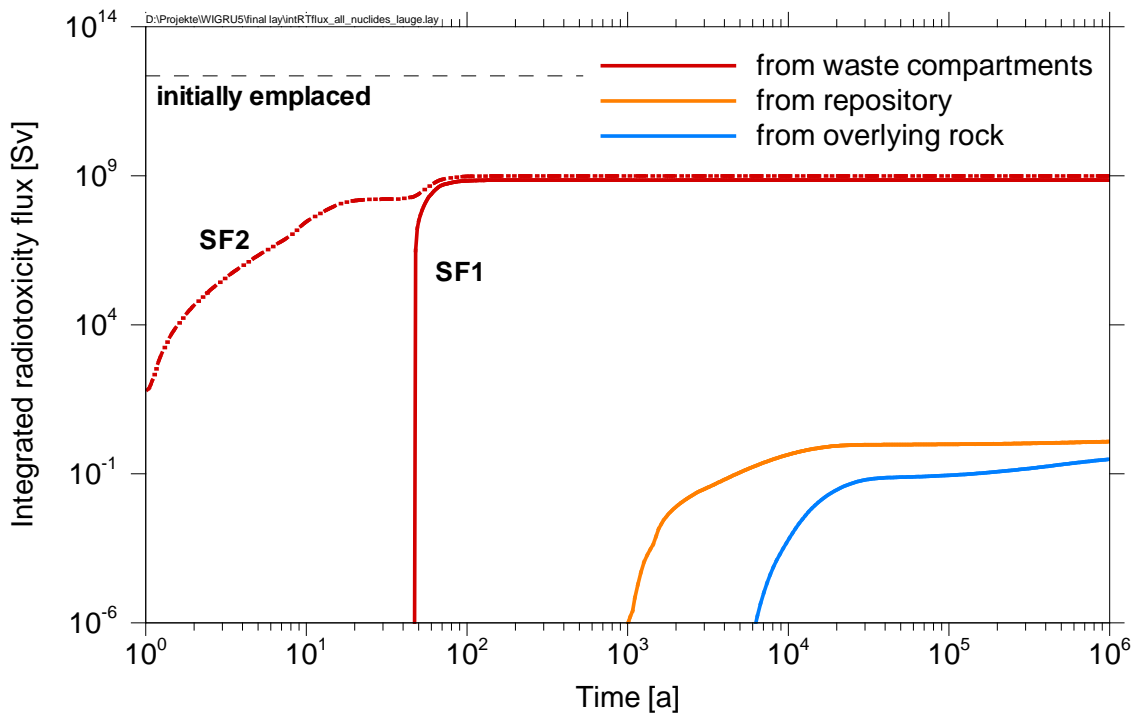

Fig. 5 Integrated radiotoxicity flux from different compartments for all radionuclides with initially employed radiotoxicity inventory for the brine inclusion scenario

2.2.2.2 Performance indicators in clay formations

Three performance indicators have also been successfully tested for a repository in clay. The different compartments are container (waste matrix and precipitate), clay formation and biosphere. Due to the simplicity of the model used in this calculations that accounts for one compartment only in which the radionuclide transport is taking place, all three performance indicators more or less give the same information in contrast to the more complex repository system in rock salt. Therefore the results are summarised in the following for the first indicator only.

The performance indicator examining the inventory in the different compartments has shown that the retention of the major fraction of the radiotoxicity inventory is achieved by fixation in the waste matrix for nearly one million of years. The retention of the radionuclides releasing from the waste matrix is achieved by sorption in the clay barriers, while precipitation of radionuclides seems to play a minor role for the overall retention. To better distinguish between the role of the compartments matrix and precipitate for the retention of the radionuclides it would be helpful to study the radiotoxicity fluxes from the matrix to the precipitate / container water and from the precipitate / container water to the near-field bentonite pore water.

A further differentiation in which part of the clay barrier system the radionuclides are retained - engineered bentonite barrier or host rock - could not be achieved by the performance indicators since only one compartment was taken into account. The reason for both deficiencies is that the current version of the CLAYPOS software is not able to give the inventories and fluxes for different compartments of the clay barrier system independently. This however will be very helpful, in particular to examine multi formation clay barrier systems as they are found in Northern Germany.

Further development of the CLAYPOS module in a future project will therefore include the calculation and output of the (i) inventories in all compartments of the clay barrier system (bentonite, host rock, adjacent formations), (ii) radiotoxicity fluxes from all compartments of the clay barrier system and (iii) radiotoxicity fluxes from the matrix. Further testing and developments of the use of safety and performance indicators for repositories in clay and the further development of the CLAYPOS module will be performed in the European project PAMINA.

2.3 German Safety Requirements

The safety criteria for the disposal of radioactive waste in a mine were issued in 1983. These safety criteria were tailored for a licensing situation at the end of a Plan Approval Procedure (“Planfeststellung”). The Plan Approval Procedure is required by the Atomic Energy Act for federal installations for the safekeeping and final disposal of radioactive waste. It is, in principle, a one-step procedure which might last for the whole duration of a project. A stepwise approach is not explicitly implemented. The Plan Approval Procedure has a so-called “concentrating effect” for several fields of law.

During the last years, the management of radioactive waste in Germany was under review since the German Government pursued the policy to develop a new waste management plan. One of the centerpieces was a revision of the safety criteria. This revision was carried out by GRS on behalf of the Federal Ministry of Environment, Reactor Safety and Nature Conservation (BMU) /BAL 08/.

The approach is based on demonstrating the confinement of radionuclides in the repository area. Calculated radionuclide concentrations in the accessible environment are seen as most important safety indicators which allow assessing the confinement capability of the repository system.

A small working group was installed in 2006 with representatives from several German and Swiss institutions. Members of the working group came from regulators as well as implementers and technical support organizations. The group met regularly in 2006 to discuss the development of guidelines for the new safety criteria. The discussion focused on the adequacy of different indicators for assessing the confinement of the radionuclides for different host rock situations and for different evolution scenarios of the repository system. Also, suitable procedures for calculating these indicators were examined.

During this process, on order of the BMU, the perspective was broadened into developing new safety criteria with the following two objectives:

- It was intended to update technical criteria according to the state-of-the-art as described in /NEA 04a/ as well as in the Safety Requirements WS-R-4 /IAE 06/.
- It was also desired to implement a stepwise approach where, at well defined decision points, a safety case will be compiled based on the knowledge achieved so far. This safety case shall be utilised to support decisions concerning the further process.

Subsequently, a draft version of new German safety requirements was published by GRS in 2007. This draft included some of the work that the working group had carried out. The draft German safety requirements were extensively discussed in several national expert groups, including the two BMU advisory groups German Reactor Safety Commission and the Radiation Safety Commission, which published a joint statement /RSK 08/. The legislative process of preparing and adopting new safety requirements is still in progress.

2.4 Natural Analogues

As already discussed in chapter 2.1 results from calculations performed with numerical models are subject to different kind of uncertainties which have to be addressed in the safety case. Thus in a safety case the conclusions drawn from numerical calculations need to be supported by additional arguments [NEA 04]. Information from natural analogues represents one important category of supporting arguments.

Their role in the safety case depends to some extent on the time period which they cover. Especially industrial or archaeological analogues can help to understand and underpin short-term processes in the repository. However, the main benefit of natural analogues in a safety case is to increase the understanding of long-term processes.

Representative analogue studies performed with regard to support a safety case for a repository for HLW in rock salt have been compiled and presented at the NEA Symposium for the Safety Case /NEA 08a/ and at the 9th meeting of the Natural Analogue Working Group (NAWG) in Munich in August 2007 /NOS 08a/. Here the major aspects from these papers are shortly summarised.

For repository concepts for high-level waste in rock salt the geological barrier is of utmost importance, since the normal evolution is expected to lead to a complete and permanent confinement of the radioactive waste in the host rock by convergence of voids. Therefore, beside the fact that more than 250 Million years after diagenesis of the evaporates a large number of salt domes exist in the North German Plain, specific arguments from analogues underpinning that the salt dome can be stable and integer over geological time frames are crucial for the safety case. In case of an early brine intrusion, which is much less likely, a number of additional processes need to be regarded in the long-term safety assessment. All relevant processes need to be implemented in the models. Natural analogues can also contribute to understanding of these processes and qualification of the respective models.

Fig. 6 shows how the key processes for safety assessment can be classified according to their time of occurrence. In the so called normal evolution scenario, shown left, the key processes can be divided into two groups. At early times processes leading to a reduction of voids, decrease of permeability of seals, and healing of excavation disturbed zones play the key role. They are mainly influenced by the temperature field in the repository area which exhibits significantly increased temperatures over a few thousand years. At extremely long time scales beyond 1 Million years, uplift and subsrosion are the key processes.

In Fig. 6 on the right the key processes for a scenario with early brine intrusion are shown. At early times temperature increase, reduction of voids and brine intrusion are the dominating processes in the system. In this scenario back pressure of fluids prolongs the process of reduction of voids by convergence. After access of brine to the emplacement area the corrosion of the container plays an important role and mobilisation of radionuclides from the waste starts after container failure. After the emplacement boreholes and/or drifts have been completely filled with brine, advective radionuclide transport, e.g. caused by further compaction of the brine filled voids, occurs. After release out of the salt dome radionuclide migration and dispersion play a role. Highest radionuclide peaks usually occur at early times when the flow rate of the brine out of the salt dome is highest.

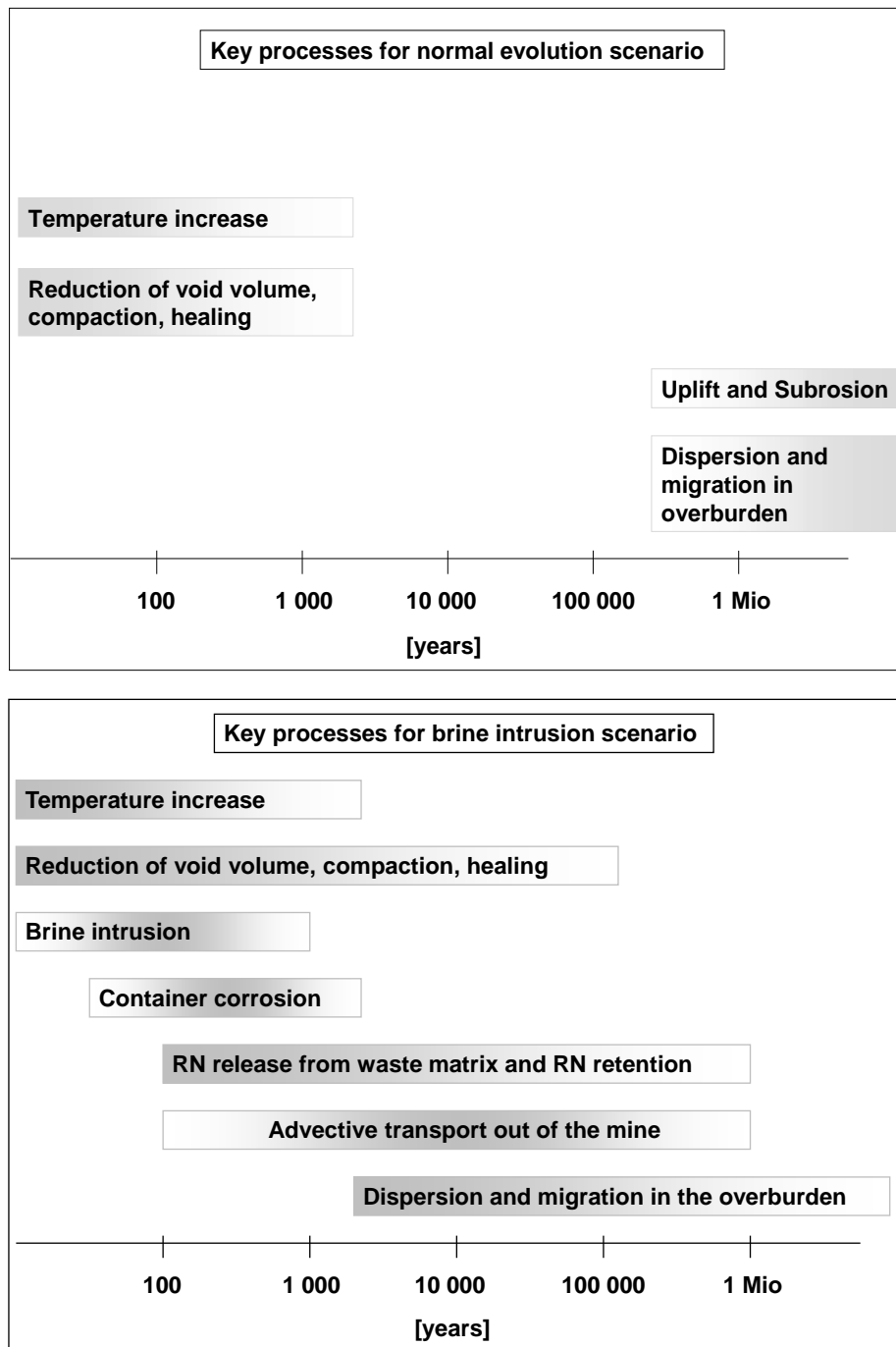

Fig. 6 Key processes for the normal evolution (top) and for a brine intrusion scenario (bottom) for a HLW-repository in rock salt. The colour of the bars indicates the importance of the process at a distinct time: grey = high; white = low

2.4.1 Natural analogues for the long-term scale

One important aspect in the safety case is the use of geological analogues to illustrate time frames of geological changes, i.e. to show the time scales geological systems have been stable. In particular the geological history of the host formation is of interest.

The formation of salt domes in Northern Germany occurred during Zechstein age about 250 Million years ago, when during a long warm period by evaporation of shallow sea water sedimentation of a large amount of salt minerals occurred. By this process salt formations of up to 1,000 m thickness were built, which have been covered by a sequence of strata during Trias, Jurassic, Cretaceous, Tertiary and Quaternary. Because of the pressure of the overlying layers with higher density compared to rock salt, the tectonic alteration of the overlying layers and viscoplastic properties of rock salt some masses of salt moved into upper levels of the crust and finally formed salt domes. As a result in northern part of middle Europe a large number of salt formations exist in a belt between 57° and 52° northern latitude from the North Sea to Poland.

The compilation of the large number of existing salt domes - more than 200 in Northern Germany - can be used as argument, that salt masses, which are soluble in water, have been undergone deformation and halokinesis but not significantly altered by subsidence. Even during times where glacial and interglacial periods occurred and periodically covered the area, where the salt formations are located, by some 100 m thick ice covers (s. Fig. 7) exposing the formations to high mechanical stress and causing inflow of a high amount of freshwater into the overburden.

Concerning the integrity of the salt dome on the one hand arguments demonstrating that external fluids from adjacent or overlying strata did not migrate into the inner of the salt dome, i.e. no fluid pathways exist in the formation are of great importance. On the other hand it is important to show that processes like subsidence do not affect the repository within early time scales, when radiotoxicity of the waste is still high.

By subsidence dissolution of salt occurs from top of the salt dome. The highly soluble minerals like halite and salt are removed and less soluble minerals like gypsum layers remain, i.e. the age of the layers decreases with depth. These remaining layers form the so-called cap rock of a salt dome. The existence of cap rocks above salt domes demonstrates that subsidence is a process of the normal evolution of a salt dome, which

has to be addressed in the safety case. Information about the impact of subsrosion can be obtained by natural observations.

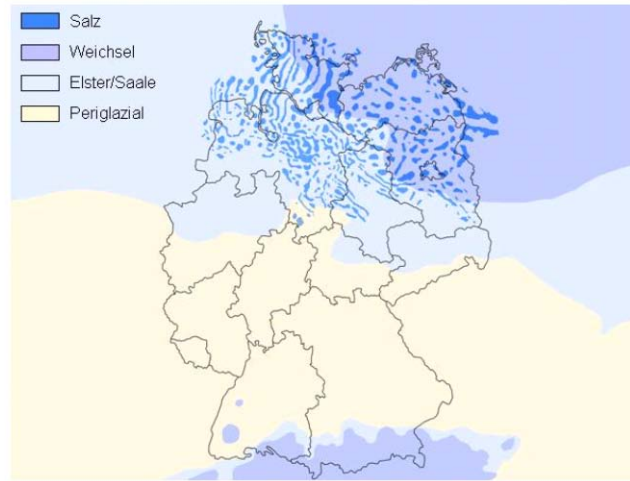

Fig. 7 Location of salt domes in Northern Germany and extension of ice covers during the last glacials

In an analogue study at the Gorleben site by the German Geological Survey a detailed investigation of the cap-rock material by analysis of cores from 49 boreholes was performed /JAR 94/. In Fig. 8 the typical stratigraphy of the cap rock on top of the Gorleben salt dome is shown. The cap rock consists of five different layers. As described above, the oldest cap rock layer is top flaser and nodular gypsum layer. The layer with the so-called cap rock breccia is exceptional, since it was not formed by the subsrosion process. The distribution of the cap rock breccia and its composition are clear evidence that it was formed in the period of Elsterian glaciation 500 000 to 300 000 years ago, simultaneously to the so-called “Gorleben Trough” due to the great load of the ice masses along the trough by which material not originating from the upper Permian was pressed into the trough.

The dating of the cap rock breccia allowed the determination of subsrosion rates by investigation of the banded gypsum. From analyses of the thickness of the banded gypsum in 49 boreholes taking into account the different content of low soluble material in the salt of each bore core subsrosion rates have been derived. The results show, that the subsrosion process is slow with rates of few 10 $\mu\text{m/a}$, i.e. few tens of meters per one million years. Considering the depth of the repository of app. 600 m below the top of

the salt dome, a very slow subsidence and also a very small uplift of the salt dome of only a few tens of meters in one million years /ZIR 91/ this will be seen as a strong argument that the salt dome will provide an appropriate isolating rock zone within the next million years.

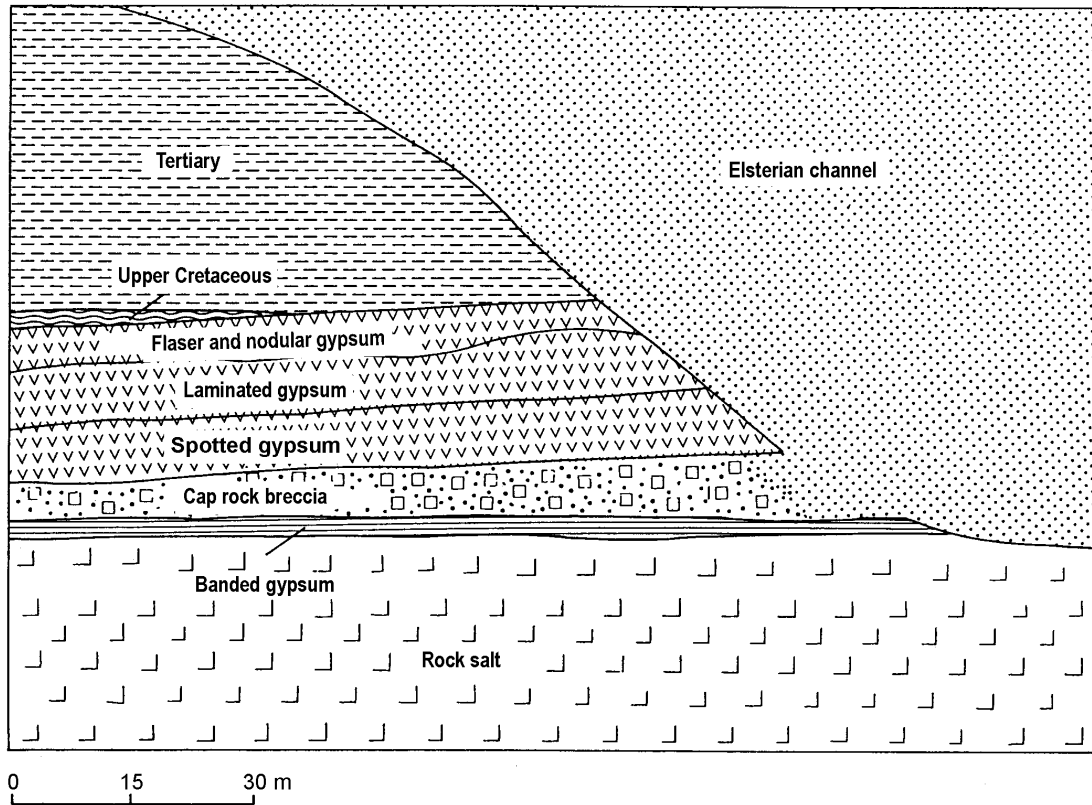

Fig. 8 Stratigraphic layers on top of the Gorleben salt dome with cap rock breccia /BOR 86/

Further arguments for the integrity of salt domes over such long time scales are obtained from analogue studies like the characterisation of brines in fluid inclusions showing that at depths higher than 800 m their composition was not altered by formation water of the surrounding rock or the overburden during the last 250 million years; the modern knowledge was summarized actually by /HER 07/. In agreement, brines enclosing inside the unstressed salt formation are characterized by element contents and isotope signatures of Permian age brines /SIE 01/. Additionally, in not tectonically stressed salt formations the element content and isotope signatures of gases in fluid inclusions show that even gas migration after formation of the layers is not significantly /MEN 05/, /SIE 07/. Some of these issues are discussed in more detail in /NOS 08a/.

2.4.2 Analogues for the early post-closure phase

In order to describe processes in the early post-closure phase of a repository technical analogue can be used, which are based upon observations in the more than 100 years old history of salt mining. Such observations show, that the sealing of an excavation disturbed zone (EDZ) around a seal leads to a significant permeability reduction within time scales depending on boundary conditions as depth and temperature. This analogue underpins results from rock-mechanical calculations, where after relatively short time periods of few tens of years in those rock areas, where seals have been installed, low permeabilities in the order of magnitude as those of undisturbed rock salt are reached.

Fig. 9 show the permeability distribution of the EDZ around a bulkhead and lined drift, which were mined in 1911 in 800 m depth in the Asse mine. The 25 m long section of the bulkhead drift was equipped with a liner of cast steel tubings in 1914, and the void between the liner and the drift surface was backfilled with concrete. This drift can be regarded as an industrial analogue with regard to the temporal evolution of an EDZ around a sealed drift. Around the drifts an EDZ of about two meters thickness exists with permeabilities increasing above values of 10^{-16} m^2 (Fig. 10, blue line). Around the lined part of the drifts all permeabilities are less than 10^{-18} m^2 . At 1.2 m depth the permeability is about two orders of magnitude and at 0.5 m depth more than four orders of magnitude below the values observed for the open drift.

This study shows the worth of an industrial analogue, where the time frame is precisely known. It also shows, that in order to confirm the constitutive models used to describe the EDZ evolution with time more effort is needed. Additional in-situ measurements, preferably around excavations of different age and, wherever possible, in the surroundings of plugs placed long times ago, would be very helpful. However, the analogue will be applied to check models are suitable for calculation of self-sealing of an EDZ in rock salt. In particular, it can be tested whether an extrapolation from short-term laboratory and field experiments to longer timescales of several decades is possible. Since much higher temperatures as in the Asse mine will occur in the repository in early post-closure phase, the sealing process will be faster. Therefore, the analogue also gives confidence, that the importance of an EDZ for performance assessment is restricted, i.e. considerable effects are only expected for the first decades of the post-closure period.

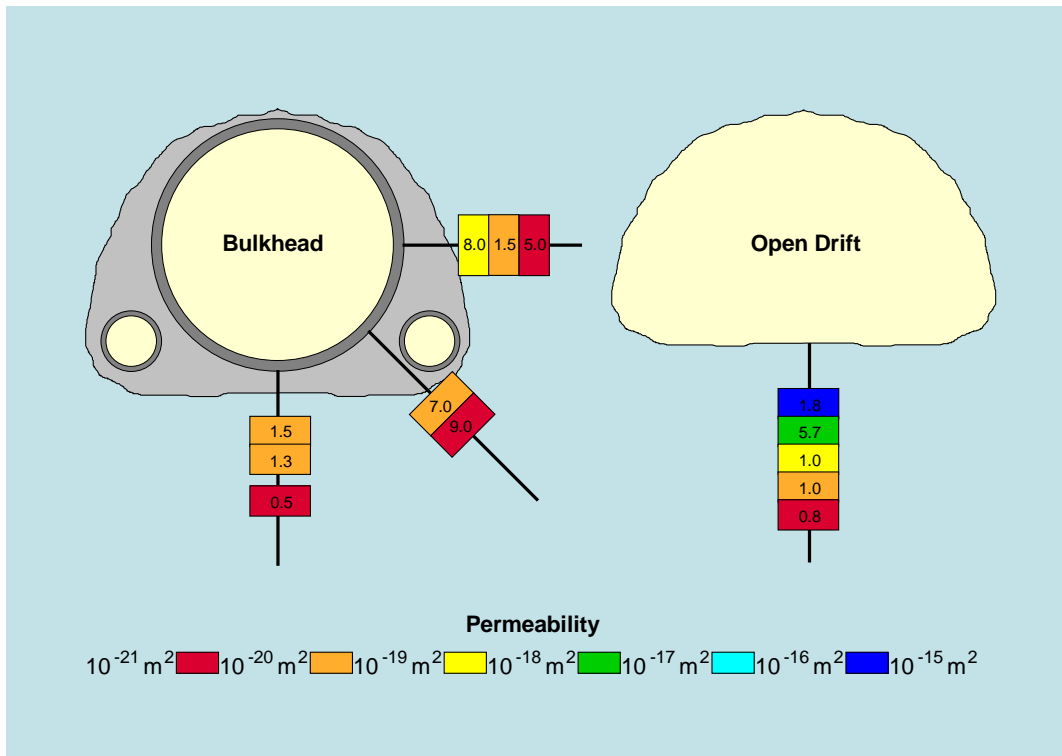

Fig. 9 Permeability of an excavation disturbed zone around a lined and an open bulkhead drift constructed 1911 in the Asse mine /WIE 04/.

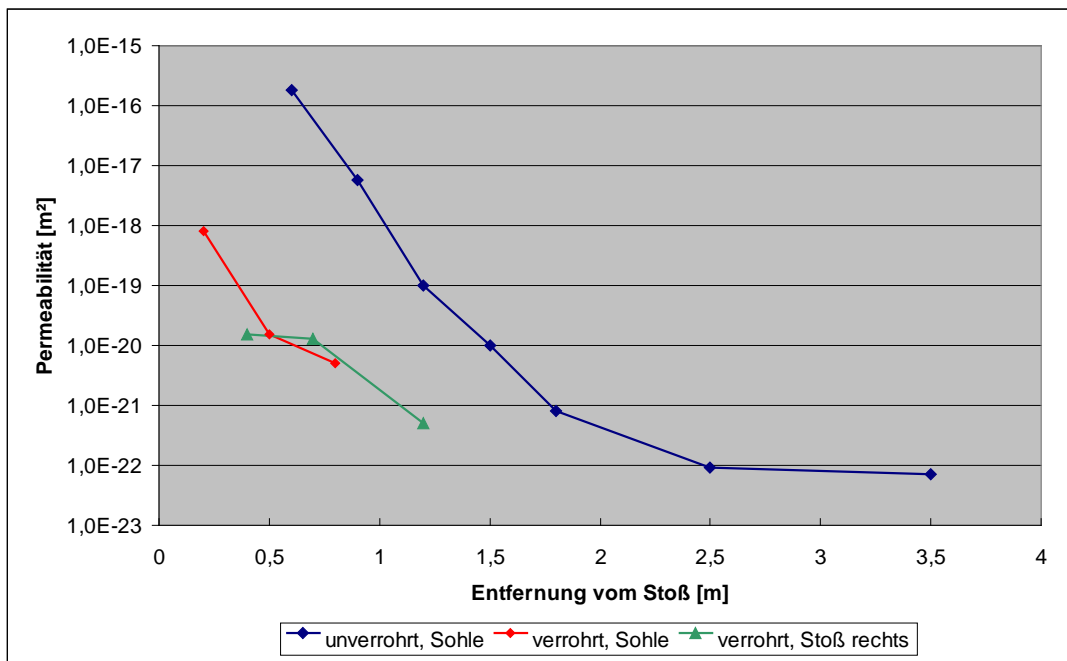

Fig. 10 Permeability versus distance from the rim of an excavation disturbed zone around a lined and open bulkhead drift in the Asse mine /WIE 04/.

These results are quite similar in comparison to in-situ experiments on open and filled drifts in other salt mines /HÄF 01/, /HÄF 04/, which also show that around the drifts an EDZ of up to two meters thickness with permeabilities between 10^{-15} m^2 and 10^{-17} m^2 exists. At more than two meters depth the permeability seems to be more than five orders of magnitude below the values observed for the EDZ near drift surface. But these investigations did not yield results on correlations between the permeability of the EDZ and the distance to the drift surface and also the time of drifting.

2.5 Scenario development

2.5.1 Human action scenarios from international studies

On the international level, most studies or safety cases for HLW-repositories consider the consequences of human intrusion scenarios. The human intrusion scenarios form a subgroup of the altered evolution scenarios considered in long-term safety analyses. Human intrusion scenarios comprise those future human actions which lead to a direct penetration of a repository. These may either cause direct releases into the biosphere or impair the barrier system of the repository or its safety functions. From the human intrusion scenarios, usually those initiated by a deliberate intrusion are not included as they are considered to be unavoidable and the radiological implications are the responsibility of the intruder.

Human actions with no direct penetration of the repository or the waste canisters form a different type of human action scenarios. These scenarios comprise those human actions which disturb the groundwater flow regime in the repository system leading to an increase of radiation exposures in the biosphere.

Depending on the national safety requirements or the implementer's strategy to demonstrate the long-term safety of a HLW-repository, the consequences for one or several different human intrusion scenarios are calculated, either as radiological doses or risks (the latter mostly in combination with an estimate of the incidence rate of the scenario). In the following, examples from some international studies will be considered as examples to these types of Human intrusion scenarios.

2.5.2 The French Dossier 2005 Argile

The Andra who is the organisation charged with the implementation of a French HLW repository presented in 2005 a comprehensive safety case showing the feasibility of a repository in a clay formation located in the Meuse and Haute Marne departments in North-eastern France. The evaluation of the repository safety /AND 05/ aimed to show compliance with the French Basic Safety Requirement (RFS III.2.f) With regard to human intrusion, two types of situations were examined:

- Situations resulting from the unearthing of cores, debris or cuttings and contaminated rock from a borehole. In these situations the radiological impact is immediately caused by an external irradiation exposure of the workers causing the intrusion.
- Situations resulting from the abandonment of one or more boreholes may be creating a partial or total shortcut of the host rock formation depending on their localisation with regard to the structures. In these situations, the potential radiological impact is delayed, when a part of the radionuclides initially contained in the waste has migrated from the package to the biosphere via the borehole. The persons potentially exposed in the medium or long term are individuals belonging to a hypothetical critical group. The calculated dose is the individual dose.

In the Dossier, the preliminary analysis of different possible cases considered a limited number of pertinent situations related to potential borehole situations. As instigating event an exploration borehole sunk 500 years after closure is assumed, when the memory of repository will be lost. It is further presumed that the event will take place after exactly 500 years (with maximum mobilised radiological inventory) and that the borehole will be permanent; these is improbable for one borehole, but will give the impact which can result from several successive drillings in nearby zones. For each repository zone containing different waste types a “reference” position close to the packages, in a structure whose diameter was sufficiently large for realistic interception, was defined for the borehole. Tab. 2 illustrates some results from the dose calculation for the abandoned borehole scenario.

Tab. 2 Scenario: Abandoned Borehole Penetration of the Repository; Peak doses and main contributors for different waste types /AND 05/

Reference package	Peak dose [mSv/year]	Date of peak dose [years]	Contributing radionuclides
B1x (non-organic packages, release no gaseous hydrogen)	0.012	770	Cl-36, Mo-93
B2 (bituminised sludge)	0.00022	12,000	Cl-36, I-129
C2 Glass	0.00065	25,000	Cl-36, I-129
C4 Glass	0.00053	23,000	Cl-36, I-129
CU1 Spent fuel	0.0072	42,000	I-129
CU2 Spent fuel	0.0012	43,000	I-129

2.5.3 The Swiss Opalinus Clay Study

According to the Swiss safety criteria HSK-R-21, the assessment of intentional human intrusion into the repository – f.e. to recover the waste – is explicitly excluded and measures should be taken to minimise the risk of inadvertent human intrusions /HSK 93/. Should intrusion nevertheless occur the repository should be designed in such a manner that degradation of performance after intrusion is limited. NAGRA as the implementer of the Swiss HLW repository presented a safety case to show the feasibility of a HLW-repository in the Opalinus Clay formation of Northern Switzerland. The NAGRA strategy includes the following measures /NAG 02a/:

- **Preservation of information** – Measures will be taken to ensure that information regarding the purpose, location, design and contents of the repository are preserved.
- **Avoidance of resource conflicts** – A site will be selected so that any foreseeable resource conflict is avoided and so that there will be no conflict with future infrastructure projects that can be conceived nowadays.
- **Compartmentalisation** – A repository design, where in the case of intrusion only a small part of the repository is affected.
- **Solidification** of the wastes ensures that only a limited fraction of radionuclides released from the waste form can be transported to the surface instantaneously.

The definition of human intrusion scenarios and the calculation of the radiological consequences will be performed within the following stage of the safety case.

2.5.4 The Swedish SR–Can Study

The Swedish Safety Criteria /SKI 02/ require that additionally to the normal evolution scenario also less probable scenarios have to be evaluated; scenarios that take into account the impact of future human activities such as damage inflicted on barriers are one part. Damage to humans intruding into the repository is categorized to the residual scenarios, which are selected and studied independently of probabilities in order to illustrate the significance of individual barriers and barrier functions.

SKB as the Implementer of the Swedish HLW repository presented a safety case to show the feasibility of a repository for the Forsmark and Laxemar site /SKB 06/. This SR-Can study is a follow-up of the Site-97-Study, which include the first descriptions of human intrusion scenarios for a repository in Granite. The study considers three scenarios of future human intrusion or actions, respectively, to meet the regulatory requirements. It is important to note that scenarios relating to future human actions should not be included in the risk calculation according to SSI general guidance.

2.5.4.1 Human intrusion - the deep borehole scenario

It is assumed that a waste canister has been penetrated by core drilling. The borehole part above the penetrated canister is assumed to be grouted. In the grouted part of the buffer the capabilities to prevent advective transport, self seal and prevent colloid transport are not maintained but backfill and buffer are assumed to retain their safety functions otherwise. The water into the cuttings of the drilling will be brought to the surface and spread on the ground on a circular area. Assumptions for the consequence analysis were:

- The canister is penetrated.
- The grouted borehole has left an open pipe between canister and surface.
- There may have been a drop in density in the buffer and backfill.
- There is no delay for the radionuclide transport in the geosphere.
- The instant release fraction of the inventory, as well as the radionuclides in the cuttings are brought to the surface and spread on the ground.

For the quantitative assessment of radionuclide release and the dose consequences of a penetrated canister, radiation exposures to a family settling on the site are considered. The dose originates from two sources: (1) The abandoned borehole used as a well by the family and (2) the cuttings containing the instant release fraction and the fuel particles spread on the ground. In both cases the engineered barriers have lost safety functions and the geosphere some of the retarding capability. The important parameters in the assessment are

- *Time of drilling* will determine the radionuclide inventory left in the canister.
- *Time of settlement* on the site using the borehole as a well and the contaminated soil for cultivation determine the content of radionuclides in the well and on the ground.
- *Amount of fuel brought to the surface* will determine the dose from the cuttings spread on the ground.
- *Instant release fraction* of radionuclides are not embedded in the fuel matrix will be immediately released.
- *Fuel alteration rate* will directly determine the release of most radionuclides under most circumstances.
- *Water flow through deposition hole* will determine the release rate of radionuclides.

Fig. 11 shows the calculated doses from the use of drinking and irrigation water from the borehole as a function of the time of drilling, Fig. 12 the doses resulting from the contamination of the ground for an adult in the first year of settlement spending one hour daily at the contaminated land area which is used for domestic farming.

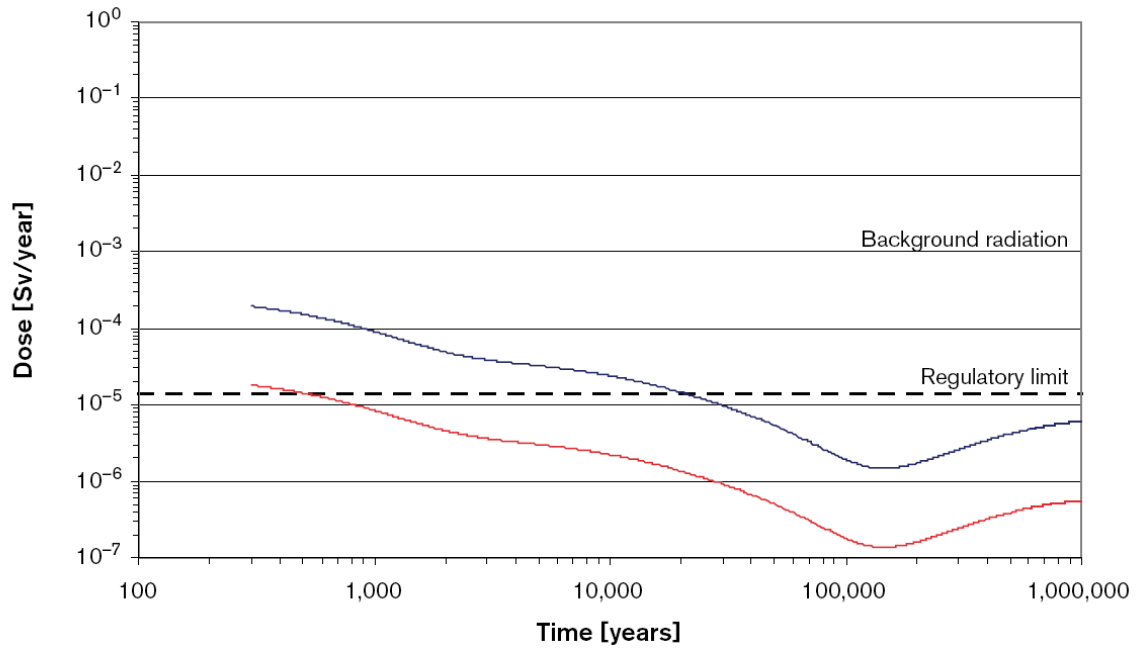

Fig. 11 Effective doses by using the borehole as a well for drinking water and irrigation at Forsmark site (red line) and at Laxemar site (blue line) /SKB 06/.

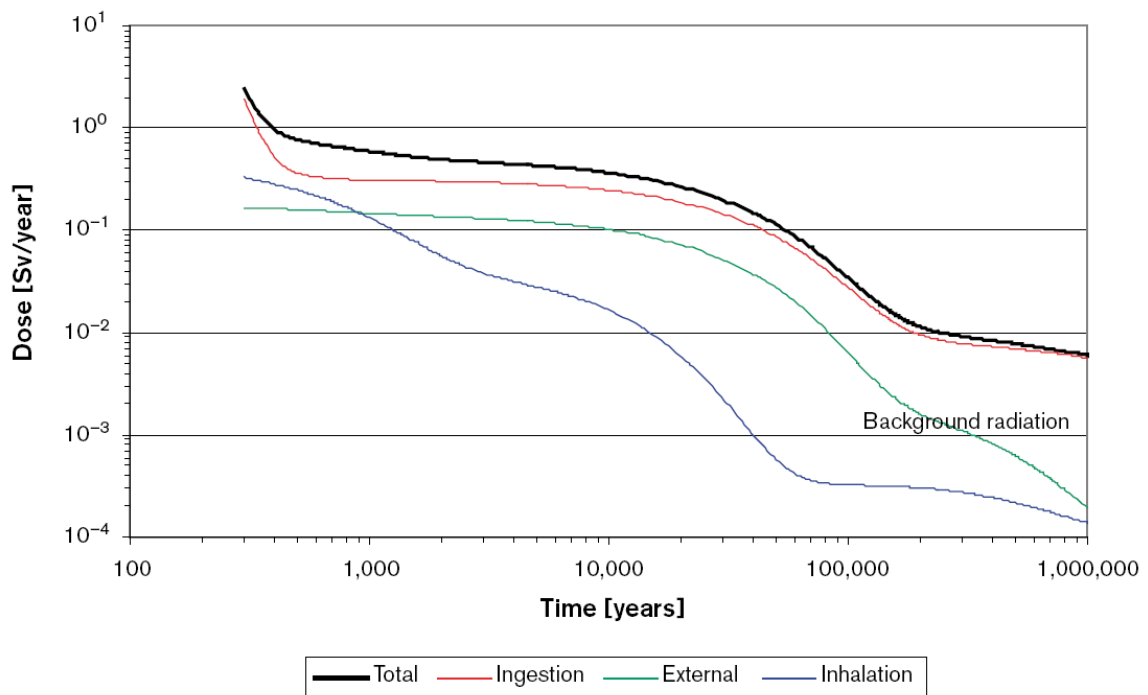

Fig. 12 Effective doses by cuttings spread on the ground /SKB 06/.

SKB interpretation of these results is as follows: if the borehole is used as a well for drinking and irrigation, the annual effective doses to representative members of critical groups will exceed the individual limit for members of the public but not the annual effective dose from the background radiation. The doses are an order of magnitude smaller at Forsmark site than at Laxemar site due to the greater capacity of the well and related dilution. Assuming the site-specific mean capacities of wells, at Forsmark the dose limit is only exceeded if the intrusion occurs during the first 500 years after closure, whereas, at Laxemar, the dose limit is exceeded if the intrusion occurs within the first 21,000 years after closure of the repository. If the instant release fraction and crushed material from the fuel elements is brought to the surface, the land is used for cultivation the same year as the intrusion occurs and a person spends time in the contaminated area, annual absorbed and effective doses may be very high. In the example the exposed person may be severely injured. In the first 400 years after closure the dose from the cuttings left on the ground will be more than 1 Sv/a.

2.5.4.2 Human action scenarios - excavation of a rock cavity or a tunnel

Additionally to the deep borehole scenario the scenario was analysed, where a rock cavity or a tunnel was constructed just above the repository whose purpose and location was forgotten. This scenario does not imply a direct intrusion into the repository but during operation of the tunnel the hydraulic gradients in its vicinity are directly affected. If the impact on the hydrologic conditions will be substantial the chemical conditions could be indirectly affected.

As covering and most plausible scenario for the conditions prevailing at the candidate sites, an open tunnel construction in a depth of 50 m below the ground surface with a cross section of 100 m² extending over the whole repository footprint along the centre line of the deposition areas was assumed. Other facilities at deeper levels or higher volume and thus higher potential impact on the repository development, as mines, hard rock laboratories and deep geological repositories for radioactive material were considered but judged unrealistic at or close to the repository site.

The analyses of the consequences of a rock cavity or tunnel in the vicinity of the repository are based on the analysis of the open repositories at Forsmark site and at Laxemar site /SVE 05/, /SVE 06/. These analyses lead to the conclusions that any impact of a tunnel at shallow depth above the repository is very limited. For the

Forsmark site, where the upper part of the bedrock (about 200 m) is much more conductive than the lower part at 400 m depth, no influence of an open tunnel construction in a 50 m depth below the ground surface on the repository for spent nuclear fuel can be expected. It was shown that the pressure disturbance of the open repository at 400 m depth is hardly noticed at 50 m depth. The high conductivity in the upper part of the bedrock at this site reduces the constructability of underground cavities and requires extensive grouting. It is unlikely that any repository type of construction would be undertaken in such rock. Additional argument is that in the existing nearby LLW repository (SFR) at a depth of about 50 m below sea level no inflow from below but rather inflow from above, i.e. inflow of sea water has been observed. Thus, a tunnel at 50 m depth or any other shallow sub-surface facility in Forsmark site should imply no consequences for the repository at 400 m depth.

For the Laxemar site the effects will also be very small if the observed decrease of hydraulic conductivity with depth will turn out to be representative for the real site conditions. Furthermore, the existence of highly conductive deformation zones close to the repository implies that very limited up-coning was observed. Thus, it cannot be expected that an open tunnel at 50 m depth should lead to up-coning at 500 m depth. While these preliminary hypotheses still have to be verified by means of numerical simulations, it can already be stated that the possible flow increase at repository level due to the open tunnel is well below, which are implied by the analyzed glacial conditions and likely also well within the ranges covered by the variants analysed for temperate climate conditions.

Additionally, the consequences of the mine in the vicinity of the Forsmark site were assessed. At this site with felsitic and metavolcanic rocks a potential for iron oxide mineralization has been identified. The mineral deposits have been assessed to be of no economic value. Nevertheless, if this judgement may be reconsidered in the future, the exploitation of such a mineralization is addressed in the SR-Can study. It was shown by a number of arguments that this rather site-specific scenario would not impact the safety functions of the repository.

2.5.5 The Belgian SAFIR 2 Study

The Belgian SAFIR 2 study is a safety case showing the feasibility of a HLW repository in the Boom Clay formation at Mol site /OND 01/. In this study, among the altered

evolution scenarios two human intrusion scenarios were considered: the “Exploitation drilling scenario” and the “Exploratory drilling scenario”. The selection of the scenarios is influenced by site specific conditions, mainly by the plasticity of the boom clay formation and the hydraulic conductivity of the surrounding aquifers.

2.5.5.1 The exploitation drilling scenario

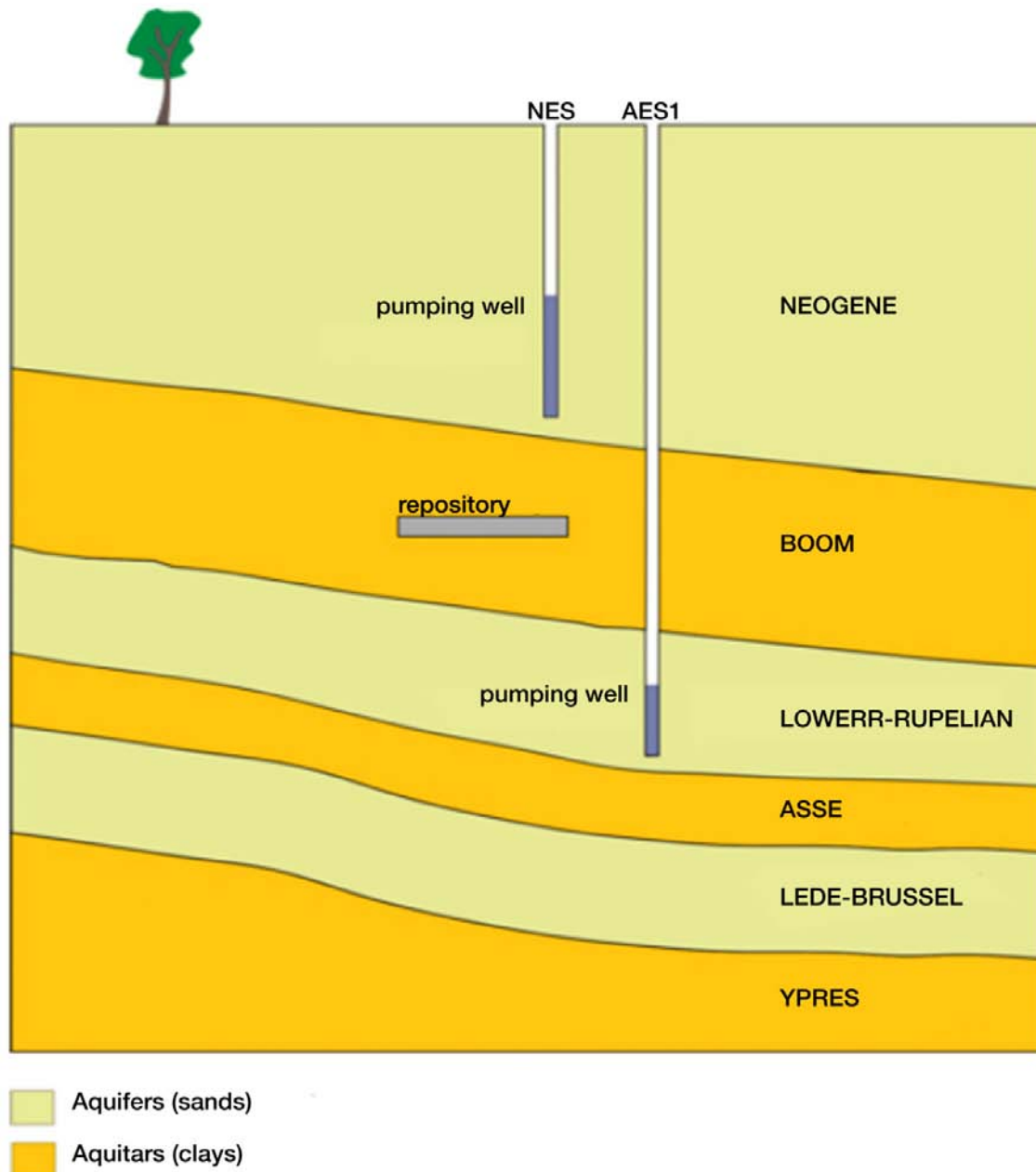

Fig. 13 Schematic representation of the ‘exploitation drilling’ scenario (AES1) and the normal evolution scenario (NES) with a pumping well.

Since the migration of radionuclides through the Boom Clay is mainly controlled by diffusion and the repository will also be located at middle of the Boom Clay layer, the quantities of radionuclides entering the underlying and the overlying aquifer are almost the same. Simulations of the groundwater flow with the regional hydrogeological model indicate that the Darcy velocity in the underlying Lower Rupelian aquifer is only about 0.02 m/a. This aquifer is from some thirty metres thickness, so there will be minimal dilution of radionuclides. Simple estimations shown that radionuclide concentrations higher by a factor of 1,000 can develop in the underlying Lower Rupelian aquifer compared to the overlying Neogene aquifer (Fig. 14). If the pumping rate is the same as in the normal evolution scenario for a well in the Neogene Sands and the same dose conversion factors are used, the dose would be 1,000 times higher, i.e. the maximum dose for a member of the reference group would be in the order of several mSv/a. The probability of occurrence of this scenario is limited by the low hydraulic conductivity of these sands and the composition of the groundwater.

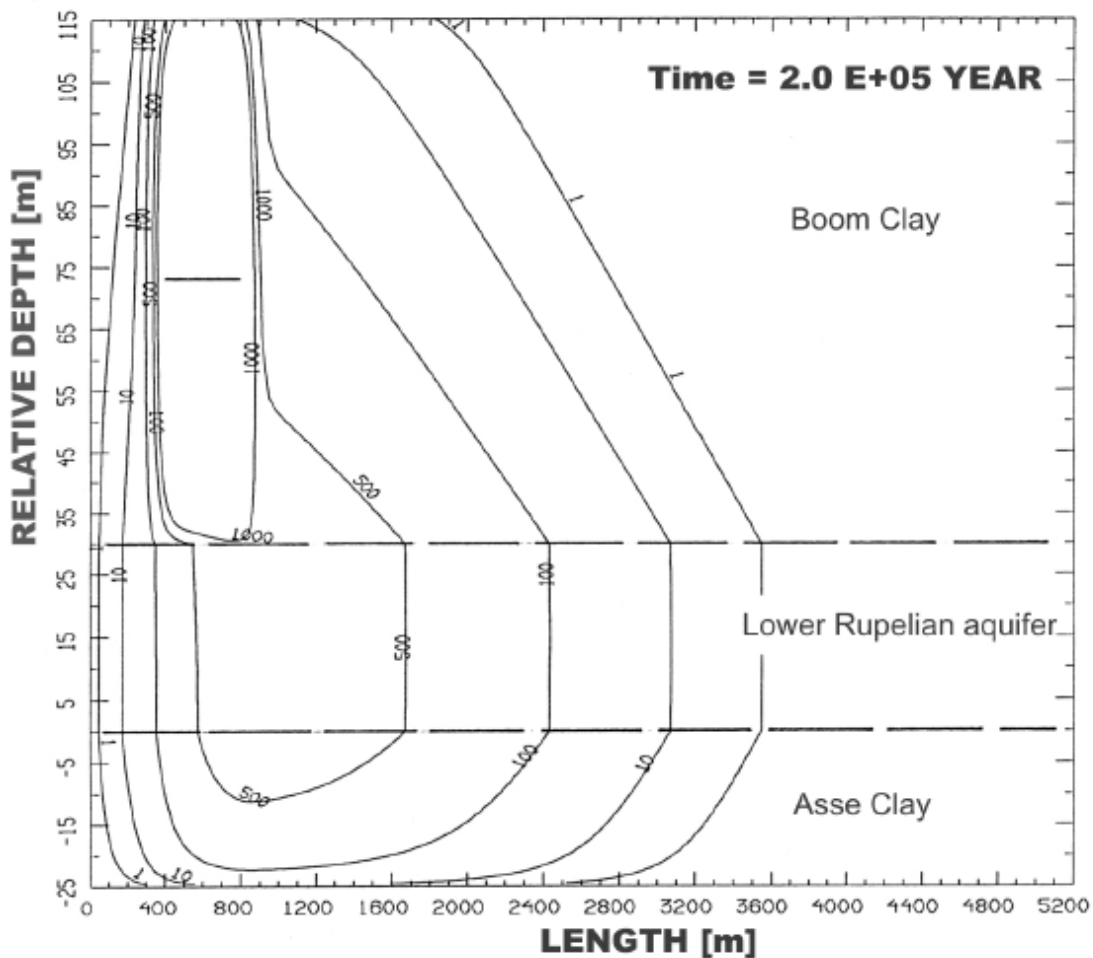

Fig. 14 Radionuclide activity concentrations (Bq/m³) within the Lower Rupelian aquifer, the boom Clay and the adjacent Neogene aquifer /OND 01/

2.5.5.2 The Exploratory drilling scenario

In earlier stages of the safety case the scenario “Examination of a borehole core” was investigated. In the scenario a core from a borehole drilled through the repository containing radioactive waste is collected and a person who is unaware that the core contains such hazardous material will analyse the material in a laboratory. The person will be exposed by external radiation and by inhalation of particles suspended in the atmosphere because of sampling. However, later it has been internationally accepted that this borehole core scenario is irrelevant for the assessment of a disposal system. It was explained by the facts that the activity released in such a scenario will be independent of the choices of disposal site and engineered barriers and the impossibility of estimating the likelihood of human intrusion. Furthermore, it is not realistic to suppose that total protection of each individual human being over many thousands of years can never be guaranteed. ONDRAF/NIRAS decided to omit the scenario and replaced this by another scenario, which is better suited to assess the robustness of a disposal system *after* an intrusion.

Actually, the Exploratory Drilling Scenario comprises the contamination of the Neogene Aquifer as a result of groundwater flow through an unsealed borehole. It is assumed that geological exploratory drilling takes place on the disposal site, a borehole pass through a disposal gallery and this borehole is not sealed. Groundwater would flow through the borehole and contact the waste. In the consequence, radionuclides will be transported upwards and contaminate the Neogene Aquifer. Owing to the plasticity of the Boom Clay the borehole will be sealed by convergence resulting in a limited period if groundwater flows through the borehole, which significantly mitigates the impact of this scenario. Calculations of the radiological impact for this scenario have not been performed so far.

2.5.6 The BfS-Study on Conceptual and safety-related issues regarding the disposal of radioactive wastes

Following the agreement between the German Federal Government and the energy supply companies of 2000 a total of 12 fundamental and safety-related issues relevant to all potential host rocks for a radioactive waste repository in Germany had to be investigated by different expert organisations on behalf of the Federal Agency BfS. One of these issues was related to the possible influences of human intrusions into a

repository and the consequences for the demonstration of its long-term safety. The results of this study were published in detail /COL 05/ and in short within the Synthesis Report of the BfS /BFS 05/.

The aim of this study was to produce a means to compare an aspect to be considered in a site selection process for a repository in Germany starting from a white map, only considering the existing geological and geographical boundary conditions and the waste amount that already exists or will be produced within the limits given by the phase-out decision. The cases of a repository only for heat-generating waste and for a repository for all types of radioactive waste were considered as variants.

The Investigations focused at different generic repository types with salt, clay, granite host rock and for a repository where the main geological barrier is formed by an overlying clay capping. For these cases, a set of six covering human intrusion scenarios which lead to an exposure of the public had been identified. Scenarios with intended intrusion or exposures of the intruder were ruled out from the outset. These reference scenarios are:

- *Mining into the contaminated host rock region:* Mining taking place in the surroundings of the repository and host rock material already contaminated is conveyed and deposited at a stockpile. The radionuclides are eluted by the rain and enter into near-surface groundwater, which is used by the population.
- *Drilling into a waste container:* An exploration drilling directly hits the waste and perforates a container. The groundwater flow through the borehole (which is assumed to be backfilled in the meantime) releases the radionuclides adhering at the borehole wall into the groundwater of a hydraulically coupled near-surface aquifer that is directly used by the population.
- *Drilling into the repository without hitting any waste:* An exploration drilling in the vicinity of the repository taps groundwater or brine in the repository region. Flow through the borehole (which is assumed to be backfilled in the meantime) releases contaminated groundwater or brine from the nearby regions of the borehole, which is transported along the borehole into the biosphere where it is used by the population.
- *Opening up of an underlying groundwater reservoir under overpressure by drilling:* An exploration drilling passes through the repository without hitting any waste and enters into an underlying groundwater reservoir under overpressure. The

groundwater raised by the overpressure entrains some contaminated brine from the repository region, seeps away at the surface and enters into a near-surface aquifer, from which water is extracted which is used by the population.

- *Opening up of a contaminated aquifer by drilling:* An exploration drilling for drinking water is put down to an aquifer located next to the repository into which radionuclides from the repository had entered. The contaminated drinking water is raised and is used by the population.
- *Solution mining of evaporite rocks:* In the repository region salt is produced by means of solution mining. Waste containers enter into the brine sump. After corrosion of the containers the radionuclides will be raised with the brine. Table salt will be produced from the contaminated brine which is eaten by the population.

In a semi-quantitative approach the probabilities of occurrence of the scenarios and their radiological consequences had been classified for each generic repository. For evaluation, the probabilities and the consequences were combined to a criterion defined as “relevance” which is a parameter which is similar, but not identical to the “radiological risk”. The results of the study are condensed in Tab. 3.

Comparing the relevance of the scenarios and the host rock types it can be stated that the relevance of the scenarios for repositories in salt and clay can be ranked into the categories “moderate” to “low” taking into account the assumed input data and boundary conditions (complete inclusion of the waste forms, repository design, etc.). Notwithstanding a relevance ranking from “moderate” to “high” was obtained for the scenario “Solution mining of evaporite rocks” for salt but only for the wastes with negligible heat generation.

For the permeable host rocks (granite and other host rocks under clay capping) relevances in the range from “moderate” to “very high” were determined for the six scenarios considered. As a result, the relevance of human action scenarios are generally higher for the permeable host rocks. From the impermeable host rocks (salt and clay) the salt overall showed slightly lower relevances (except for the solution mining scenario, which mainly results from the comparatively lower probabilities of occurrence).

Tab. 3 Comparative rating of the relevance of different human intrusion scenarios and geosystems (from /SKR 05/).

Categories in brackets apply for the case that pressurized gas is stored in the host rock after creation of secondary porosity

Geosystem	Salt Diapir	Salt bedded 800 m	Salt bedded 1.300 m	Claystone	Granite	Other Rocks with Clay Capping
Scenario 1. Mining within contaminated host rock						
total consequence	- (+++)	- (+++)	- (+++)	- (+)	+++	+++
probability of occurrence	- (+)	- (+)	- (+)	+	+	+
relevance	- (++)	- (++)	- (++)	- (+)	++	++
Scenario 2. Drilling into a waste container						
total consequence	++	++	++	++	++	++
probability of occurrence	+	+	+	++	++	+++
relevance	+ / ++	+ / ++	+ / ++	++	++	++ / +++
Scenario 3. Drilling into the repository without hitting waste						
total consequence	++	++	++	++	++	++
probability of occurrence	+	+	+	++	++	+++
relevance	+ / ++	+ / ++	+ / ++	++	++	++ / +++
Scenario 4. Drilling into a reservoir with overpressure						
total consequence	++	++	++	++	+++	++
probability of occurrence	+	+	+	++	++	+++
relevance	+ / ++	+ / ++	+ / ++	++	++	++ / +++
Scenario 5. Drilling into contaminated aquifer						
total consequence	-	- (++)	- (++)	-	++++	++++
probability of occurrence	-	- (+)	- (+)	++	+++	+++
relevance	-	- (+ / ++)	- (+ / ++)	-	+++ / ++++	+++ / ++++
Scenario 6. Solution Mining of evaporites						
total consequence	+++	+++	+++			
probability of occurrence	++	+++	+++	-	-	-
relevance	++ / +++	+++	+++	-	-	-

relevance: ++++ very high, +++ high, ++ moderate, + low, - no consequence(s)
caused by: **blue** – waste with negligible heat generation, **violet** – all waste categories

2.5.7 Results from the German scenario working group

The German scenario working group was established in 1997. Its main objectives are:

- Establishment of a common understanding with respect to various aspects that are of relevance for scenario development,
- Discussion of new international developments and trends,
- Development joint views and to publish them in position papers.

The members of the working group from Bundesamt für Strahlenschutz (BfS), Bundesanstalt für Geowissenschaften und Rohstoffe (BGR), Deutsche Gesellschaft zum Bau und Betrieb von Endlagern (DBE), Forschungszentrum Karlsruhe (FZK), Gesellschaft für Anlagen- und Reaktorsicherheit (GRS) mbH, Helmholtz-Zentrum München für Gesundheit und Umwelt (HMGU) and Technical University Clausthal (TUC), represent those German institutions which pool the respective expertise in scenario development.

After initial phase the working group was dormant, but resumed work in 2006. Since 2006 the main topic was the treatment of human intrusion in the safety case. Human intrusion scenarios describe evolutions of the disposal system if the barrier system of the repository is directly destroyed, at least partly, due to human actions. In the result the isolation of the waste is no longer ensured.

On the international level, human intrusion scenarios are considered in the safety assessment for deep geological repositories albeit not in a consistent manner. In some countries selected human intrusion scenarios are considered in the safety analysis, equivalent to other possible future evolutions. In other countries, human intrusion scenarios are considered in the safety case but separated from the other evolution scenarios. Also, various human intrusion scenarios are considered in the different nations. They differ significantly with respect to type and point in time of the initiating event, the exposition type and exposition pathway, the estimated probabilities of occurrence, the assessment of the consequences, and the group of affected persons. These differences result from the different disposal concepts, site-specific conditions and national regulations.

Against this background the scenario working group developed a joint position to treat human intrusion scenarios in future German safety assessments /ARB 08/. The major aspects of the position paper are outlined in the following:

It is the clear view of the working group, that human intrusion must be treated and appreciated within the safety case. Future human intrusion into the sealed repository with subsequent radiological consequences cannot be ruled out ultimately, even though disposal in deep geological strata aims at providing maximum protection of man and environment also for future generations and impedes substantially any access to the waste.

A detailed analysis of human intrusion into the geological repository on the basis of a systematic scenario development would require predicting future human actions and motives as well as the technological state of the art of future generations. The working group adopts the position that such a prediction is not possible. It follows, that future human intrusion cannot be treated within a systematic scenario development process. Therefore, human intrusion must be treated separately.

Human intrusion can be intended by future generations or it can occur unintentional. Intended human intrusion means that the society has knowledge about the existence of the repository and its associated risk potential. The responsibility for any intended human intrusion bears the acting society. According to the working group only unintentional human intrusion has to be considered in the safety case.

The working group adopts the position that the knowledge of the repository and its risk potential can be preserved for several hundred years and that it can be made available to any persons planning to dig in the deep underground. On the basis of experiences with mining archives that are still maintained in Germany, 500 years seems to be a plausible time period. Therefore, the working group recommended to assume any human intrusion only after 500 years.

During planning and construction of the repository suitable and reasonable measures should be taken, which prevent or impede any unintentional human intrusion and/or which reduce the associated consequences. However, these measures must not compromise the repository safety. According to the working group, the most effective measures to prevent human intrusion are to position the repository in deep geological strata and to foster as long as possible preservation of the knowledge about the

repository and its associated risk potential. This will restrict the potential for unintentional human intrusion and the resulting consequences.

In taking the decision to concentrate radioactive waste in a repository and to isolate it from the biosphere, inherently the possibility has to be accepted that in case of human intrusion into the repository permissible radiological limits will be exceeded. Owing to the inability to predict the necessary assumptions and boundary conditions, the consequences of any human intrusion cannot not be quantified plausibly. Therefore, the working group holds that it is not sensible to compare consequences from human intrusion scenarios with regulatory radiological limits.

Selected scenarios shall be used in order to assess measures which aim at reducing consequences from human intrusion. These scenarios must be based on actual repository design and site-specific conditions but need not to be conservative.

The working group recommended confining the spectrum of human intrusion scenarios, f.e. for salt as host rock to the sinking of an exploratory drilling, the construction of a mine and the preparation of a cavern. Finally the working group recommended that the regulator should establish the boundary conditions for the development of such scenarios.

3 International developments

3.1 OECD/NEA RWMC

Radioactive Waste Management Committee (RWMC) is an international committee made up of senior representatives from regulatory authorities, radioactive waste management agencies policy making bodies and research and development institutions. Its purpose is to foster international co-operation in the management of radioactive waste and radioactive materials amongst the OECD member countries. The main tasks of the RWMC are to constitute a forum for exchange of information and experience on waste management policies and practices in NEA Member countries to review the state-of-the-art in the field of radioactive waste and materials management and to conduct international peer review of national activities in the field of radioactive waste management like R&D programmes, safety assessments and specific regulations.

The NEA's 50th anniversary celebration took place in October 2008. The RWMC Bureau has been informed of plans for the development of documentation in support of the 50th Anniversary Celebration. The Bureau and the Committee will contribute to this including a statement on the final disposal of radioactive waste in geological formations entitled: "Where we stand on geological disposal by the time of the NEA's 50th anniversary".

3.1.1 Recent international developments

The OECD membership will continue to enlarge. New candidate countries include Russia, Slovenia, Israel, and Chile. These countries are on a path to accession within three to five years. Russia and Slovenia are observers already in OECD committees. Co-operation is being enhanced with South Africa and Brazil. Poland, an OECD member, was accepted to be involved in NEA activities as an ad-hoc participant. A Memorandum of Understanding and broad co-operation agreement are being explored with China.

3.1.1.1 Research and development

The Steering Committee has released a statement on Qualified Human Resources. Amongst the messages of this statement is the point that international research

programmes and co-operations represent a good avenue to address lack of resources. In this spirit, RWMC supports actually the three following international working groups:

- the Integrated Group of the Safety Case (IGSC)
- the Forum on Stakeholder Confidence (FSC)
- the Working Party on Decommissioning and Dismantling (WPDD).

During RWMC-41 it was stated that the RWMC has a vibrant and effective pool of human resources and expertise to call upon in these groups.

FSC

The Forum on Stakeholder Confidence (FSC) facilitates the sharing of experience in addressing the societal dimension of radioactive waste management and explores means of ensuring an effective dialogue with the public with a view to strengthening confidence in the decision-making processes regarding the siting and safety analysis of geological repositories.

The FSC convenes a series of alternating meetings and workshops. The annual meetings include topical sessions on specific issues of interest and are used for planning and to elaborate the lessons learnt from the workshops. National workshops, held annually parallel to the workshops, focus on stakeholder involvement in waste management issues in the host country. So far country workshops have been held in Finland (2001), Canada (2002), Belgium (2003), Germany (2004) and Spain (2005). The issues currently of interest to the FSC include the link between reversibility and retrievability (R&R) and stakeholder confidence, the changing dynamics of interactions among institutions, communications, tools and processes to help society manage RWM decisions and increasing the value of RWM facilities to local communities. During RWMC-41 it was confirmed that FSC modus operandi of annual meetings, combined with country workshops, continues to be effective.

It was remarked: before looking afar (chemo-toxic area) additional examples that are critically perceived by the public within the field of radioactive waste disposal should be considered and evaluated by the FSC. Modern study cases are the discussion of a study by ETH Zürich on “cracks” in clays and the actual situation of the Asse mine, Germany.

WPDD

The Working Party on Decommissioning and Dismantling (WPDD) brings together senior representatives of national organisations having overview of decommissioning and dismantling (D&D) issues as regulators, implementers, R&D experts or policy makers. WPDD is mandated to increase the outreach and efficiency of both RWMC and NEA decommissioning in OECD member states. In this regard, the strategy plan up to 2009 represents an important document which addresses among others international developments concerning the management and the improvement of decommissioning techniques.

During the RWMC-41 it was reported that regarding decommissioning technology and off-the-shelf technologies have been applied successfully but there is a need for R&D that could result in significant improvements to techniques and tooling leading to lower doses, less waste and greater efficiency. Waste management and harmonization of clearance criteria for materials continues to be a significant issue.

3.1.2 Recent Documents

Discussed at the RWMC meeting in March 2007 and proposed during the Berner conference in October 2007 RWMC has published a statement on geologic disposal entitled "Moving on with Geologic Disposal: An NEA/RWMC Collective Statement".

A proposal justifying the conclusion, that it is possible to perform the safe disposal of radioactive waste in geological formation, underwent a discussion during RWMC-41. The national delegates were in favour of the release of the statement, which is considered useful and timely, available in NEA/RWM(2008)5/REV1.

With "Recommendations of the International Commission on Radiological Protection (ICRP)", „Safety Fundamentals“of the IAEA and "Joint Convention on the Safety of Spent Fuel Management and on the Safety of Radioactive Waste Management“ international guidelines for the regulation and implementation of geological repositories on national basis have been worked out in the recent years. Future developments will increasingly benefit from internationally conducted research projects.

3.1.3 Country Reports

In 2007 a new guideline of the country reports has been made available by the RWMC Bureau. Intention was to streamline the provision of information and make it more readily available both to colleagues, specialists and the interested publics. Attention to RWMC-41, PTKA and GRS have provided a contribution to the German country report highlighting the main topics of BMWI's research programme from 2007 to 2010. In this contribution it is being reported that the work founded by BMWi will be focusing on "Disposal Concept and Subsystems" and "Data and Tools used in Safety Analyses" and again a safeguard related topic. The programme is rock type prioritized in the following order: rock salt, argillaceous rock and crystalline rock.

3.2 IGSC

The NEA/OECD working group "Integration Group for the Safety Case" (IGSC) is the most decisive committee dealing with new developments relating to the safety case on an international level and thus also with long-term safety analytical issues. The IGSC currently acts as the most important advisory board of the RWMC (see Chapter 3.1) on questions relating to final geological disposal of long-lived and high level radioactive wastes. The main emphasis of the IGSC activities are strategies and methods for characterizing and assessing repository locations as well as the further development of scientific foundations and methods of a "safety case". The work of the IGSC can be classified into three categories: core activities, technical activities and cooperative projects.

3.2.1 Core Activities

Projects relating directly to the "safety case" belong to core activities. They represent the central objective of the IGSC work and are essentially performed by the IGSC members themselves. The preparation of a status report, f.e. (NEA 2004), describing the fundamentals and the essential elements of a "safety case" with corresponding examples belong hereto. It is the objective of the INTESC initiative ("INTERNATIONAL Experience in developing Safety Cases") to analyse existing safety cases and those, which are currently being developed, and to document the experience made in the individual countries. The important concepts are to be identified. Additionally, it is to be revised if there is agreement and dissent among the participating organisations. The

progress made in the last decade is to be demonstrated in general. The long time period, which are to be considered for a safety case for the post-operational phase of a repository, represent a great challenge. Processes which are characterized by very different time scales take place. These processes, the corresponding uncertainties and the effects of the processes on the development of the repository system have to be identified, assessed and communicated in a safety case. In 2004 the IGSC have organized a workshop on this topic to revise different periods of time are dealt within safety analyses of the individual countries. As a result an initiative was founded with the objective to document the current state of the discussion in the individual countries. The significance of periods with respect to different aspects of a safety case were looked into, among other things with respect to regulatory aspects, features, events and processes (FEPs) and scenarios, the use of different model approaches, the treatment of uncertainties and the use of different safety indicators. The figure exemplary shows the uncertainties growing over time restrict the predictability of individual components of the repository. The development of a system from technical barriers and host rock, which can externally only be impaired by very slow geological changes or very unlikely influences like human impacts, can be forecasted over longer periods of time as the development of a hydrogeological system which is subject to shorter term influences like climate changes. Further core activities are currently carried out relating to the stability of the geosphere as well as on dealing with uncertainties in a safety case in general.

3.2.2 Technical Activities

The second category, the technical activities serve the purpose of improving the integration of the technical and scientific basis in a safety case. These activities are organised and closely monitored by the IGSC. The work of the last few years was determined by two longer projects: the role of the technical barriers in a safety case (EBS) and the AMIGO programme.

It was the objective of the EBS project to compile experiences of the individual countries to illuminate all aspects of the technical barrier systems in the context of a safety case. Four focus topics discussed on special workshops characterised the project. The first workshop "Requirements and Limitations in the Design of Technical Barrier Systems" took place in Turku, 2003. This workshop made recommendations to approach the development and design of technical barriers in repositories.

Management systems are very beneficial here. It was further discussed how the requirements of different stakeholders can be integrated into the decision making process. The second workshop to “Processes” took place in Las Vegas, 2004. It examined how relevant EBS processes can be identified, how they can be considered during development and design as well as in long-term safety analyses and in which form they can be illustrated systematically and transparently. The third workshop in La Coruña comprised all aspects of modelling. For description of processes in technical barriers there are already great experience and expertise in process modelling and modelling in integrated safety analyses. There is only limited demand for developing new codes. The treatment of uncertainties, especially the step from process modelling to modelling in integrated safety analyses, and “Up-Scaling” still represent a great challenge for which further research work is necessary. At the fourth workshop in Tokaj to “Design Confirmation and Demonstration” strategies, approaches and methods were illustrated which can support and demonstrate the suitability and operational reliability of technical barriers. A status report on the project is currently being prepared.

It is the objective of the AMIGO project (“Approaches and Methods for Integrating Geologic Information in the Safety Case”) to improve the understanding of geosphere behaviour as an important barrier of a repository system and to promote the communication between the participating countries. This activity is described in detail in section 0.

3.2.3 Co-operative Projects

The third category, the co-operative projects are highly specialized activities attended to by experts who do not belong to the IGSC and in which not necessarily all IGSC members are interested. The Thermodynamic Data Base (TDB) project, the Sorption project, the Clay Club, and the FEP Data Base belong hereto. The first two activities are described below.

The benefit of TDB project is the development and documentation of a comprehensive, consistent, quality assured thermodynamic database for elements which are important for a long term safety analysis. The TDB project already started in 1985. Meanwhile there is a comprehensive database for the elements uranium, americium, neptunium, plutonium, technetium, zirconium, nickel, selenium and zircon, which are documented in individual reports. Data of complex compounds with inorganic and simple organic

compounds, which can occur in a final disposal system, are contained herein. The database of inorganic complexes and compounds of thorium, iron, tin and molybdenum is in work. Results of this co-operation represent an important input for the development of the consistent German thermodynamic database THEREDA project /THE 07/. The modern Phase from 2008 up to 2012 will address items identified by a questionnaire to the 17 sponsoring organisations in 13 countries. Several Committee members commended the high quality products of this project.

3.2.4 Future Work

At present numerous activities of the IGSC work programme are being completed. For this reason a new programme determining the activities of the next four to five years was prepared in 2007. Important activities with regard to the German programme are:

One result of the EBS and AMIGO projects is the importance of an exchange platform in the form of workshops. In future topics relating to technical barriers and the geosphere shall be regarded in a more cross-linked way, i.e. the interdependencies of the two components. Current relevant topics are the effects of cementitious materials and gas migration in a final repository system.

A new working group shall compile and assess the developments of the methodologies in long-term safety analysis of the past 20 years. The last NEA status report on this topic dates back to the year 1991. Since that time the safety analysis procedures and methodologies have been further developed, in particular, the safety case concept has been evolved. The statements continue to apply, the methods have been developed further and also the extent, that these methods are concept-specific or universally applicable as well as the role of safety analyses in a safety case shall be worked out among other things. The results of international projects, like PAMINA as well as GEOSAF coordinated by the IAEA shall be also incorporated here.

During monitoring a large number of parameters in the final repository system under review is measured. Such activities can be carried out at all points in time during final repository development. At early stages such measurements primarily serve the purpose of determining basic data or securing site models. During final repository construction monitoring results can also be used for securing models, but in addition they can also be taken to review the influence of the construction work on the host rock formation. Monitoring during final repository operation can supply findings on the

stability of the technical constructions in the host rock formation. Finally monitoring can also be carried out in the post operational phase to demonstrate that the system behaves as expected. The IGSC plans to exchange and compile the experience of the individual member organisations on this topic, too. To initiate this exchange, a workshop with its main emphasis on technological aspects shall be carried out in 2009/2010.

The IGSC is also represented in a new OECD/NEA Expert Group on Assay Data on the concentration of isotopes in Spent Nuclear Fuel (EGADSNF) /RUJ 07/. The objective of this group is to compile data from post-irradiation examination in a comprehensive database and the identification of data gaps for most relevant radionuclides. Results from such a database provide a useful input for supporting the waste management in general and long-term safety assessments of repositories. However, prioritized lists of isotopes of interest and their accuracy of inventories for waste disposal are somewhat different from other projects, e.g. reactor safety. In the field of safety assessment of spent fuel and vitrified high-level waste repositories, long-lived fission products are very important radionuclides besides long-lived actinides. For the waste disposal safety assessment, the accuracy of the radionuclide inventories may not need to be precise compared with other project needs because of the large uncertainties inherent in dose calculation over long time frames. However, it would be sensible to achieve much better precision in this area and to confirm or improve the accuracy of inventories evaluation if more assay data are available for isotopes of interest in waste disposal safety assessment. is a compiled list of radionuclides of interest based on the information that interested IGSC member organizations provided. The list is based on results of dose impact analyses in waste disposal programmes of each country. The table includes information on the radionuclides of interest, relative order of importance and required measurement precision for each IGSC member organization /ISH 08/.

Tab. 4 Isotopes of primary interest for the disposal of spent fuel and high-level vitrified waste (shown with the symbol ■)

	NAGRA	ONDRAF ⁱ	NWMO ⁱⁱ	SKB ⁱⁱⁱ	RAWRA ^{iv}	GRS-Bs ^v			NUMO/ JAEA ^{vi}
						salt	granite	clay	
¹⁴ C	■		■	■	■	■ ^B	■ ^A	■ ^B	■
³⁶ Cl	■	■(20%)	■	■	■	■ ^B	■ ^A	■ ^A	■
⁴¹ Ca			■						
⁵⁹ Ni					■	■ ^B			
⁷⁹ Se	■	■(50%)	■(Fac.10)	■		■ ^A	■ ^B	■ ^A	■
⁹³ Zr			■		■				
^{93m} Nb									
⁹⁴ Nb							■ ^B		
⁹³ Mo							■ ^B		
⁹⁹ Tc		■(20%)	■(50%)		■	■ ^B			■
¹⁰⁷ Pd									
¹²⁶ Sn		■(20%)	■(Fac.3)	■	■	■ ^B	■ ^B		
^{126m} Sb					■				
¹²⁶ Sb					■				
¹²⁹ I	■	■(20%)	■(<50%)	■	■	■ ^A	■ ^A	■ ^A	■
¹³⁵ Cs					■	■ ^A	■ ^A		■
¹³⁷ Cs			■(<5%)						
¹⁵¹ Sm									
²¹⁰ Pb					■				
²²⁶ Ra					■	■ ^B	■ ^B		
²²⁷ Ac									
²²⁹ Th					■				
²³⁰ Th					■	■ ^C	■ ^C		
²³² Th									
²³¹ Pa					■				
²³³ U					■				
²³⁴ U						■ ^C	■ ^C		
²³⁵ U					■	■ ^B	■ ^C		
²³⁶ U					■	■ ^B	■ ^C		
²³⁸ U					■	■ ^C	■ ^C		
²³⁷ Np			■(<5%)	■		■ ^B	■ ^B		■
²³⁸ Pu									
²³⁹ Pu			■(5-10%)		■	■ ^C	■ ^C		
²⁴⁰ Pu			■(5-10%)			■ ^C	■ ^C		
²⁴¹ Pu			■(5-10%)	■		■ ^C	■ ^C		
²⁴² Pu					■				
²⁴¹ Am			■(<5%)		■	■ ^C	■ ^C		■
^{242m} Am									
²⁴³ Am					■				
²⁴⁵ Cm									■
²⁴⁶ Cm									
Mo _{Tot}			■						
Te _{Tot}			■						

-
- i Dominant radionuclides in case of spent fuel disposal in a clay layer within the Belgian radioactive waste disposal programme. The order of importance: $^{129}\text{I}, ^{79}\text{Se}, ^{126}\text{Sn} > ^{36}\text{Cl}, ^{99}\text{Tc}$. The desired accuracy of the measurements shown for each isotopes in the parentheses.
- ii Isotopes important to long-term safety assessment of used fuel. The number shown in the parentheses is reported accuracy based on a comparison between ORIGEN-S analysis and CANDU/PWR fuel assay data. Mo(total) and Te(total) are potential chemical risk contributors present as fission products. ^{137}Cs is important for scaling of difficult-to-measure species. More important species are: ^{129}I , ^{36}Cl , ^{14}C , ^{241}Pu , ^{241}Am (parents of Np^{237})
- iii The prioritized list of Isotopes of interest for spent fuel management at SKB. Note that also the contents of ^{238}U and ^{234}U and their daughter products are crucial for the results of the safety assessment. However, the inventories of the U isotopes follow trivially from the amount of spent fuel and its enrichment and the inventories of the daughter products then follow trivially and with negligible uncertainties from the Bateman equations. These nuclides are thus not listed as prioritized regarding the need to compile additional inventory data.
- iv The prioritized list of radionuclides for waste management and disposal based on reference geological repository project in RAWRA.
- v Isotopes of primary interest based on dose relevance of the radionuclides and derived from the results of previous long-term safety assessment studies for radioactive waste repositories of rock salt, granite and clay in particular for repository with spent fuel. The isotopes are divided into three categories:
- A: Most important isotopes. The accuracy of inventory should be no more than 10%.
- B: Important isotopes. The accuracy of inventory should be no more than 50%.
- C: Not directly dose relevant radionuclide but their inventory as other nuclides are important.
- vi Isotopes dominant to the estimated dose in the H12 safety analyses of HLW (vitrified waste) disposal, and in the safety analyses of TRU waste disposal.

3.3 AMIGO

Convincing safety cases require good general scientific understanding of the geosphere, its evolution and its interaction with the repository. The development of the safety case proceeds iteratively with site characterisation, and interdisciplinary communication is of key importance to the success of both. During the last decade considerable experience has been gained internationally with the collection, synthesis and presentation of multi-disciplinary geoscience data to describe existing site-specific conditions and the evolution and integrity of the far-field with high relevance to repository design and safety. In order to compile and evaluate the information and experience from the different countries the international project AMIGO “Approaches and Methods for Integrating Geological Information in the Safety Case” was established in 2003 by OECD/NEA. The objectives of the project were

- to understand the state of the art and identify means to improve the ways in which safety cases are supported by geological information,
- to contribute to the development of the methods for representing the geosphere in safety cases,
- to define terminology for communication and interaction between groups engaged in site characterisation and safety assessment in support of safety cases,
- to clarify the role and application of geoscientific information and evidence applied in safety cases,
- to clarify the relationship between and information requirements for site characterisation and safety assessment modelling, and
- to foster information exchange between international radioactive waste management geoscience programmes, and between academic, regulatory and implementing bodies.

Amigo was structured as a series of workshops. The first workshop was held at Yverdon-les-Bains, Switzerland in 2003 and was focused on “Building Confidence Using Multiple Lines of Evidence”. The second workshop took place in 2005 at Toronto, Canada, and was concerned with “Linkage of Geoscientific Arguments and Evidence in Supporting the Safety Case”. The third and last workshop “Approaches and Challenges

for the Use of Geological Information in the Safety Case” was held in 2008 at Nancy, France. Detailed information can be found in the proceedings from the workshops and the compendium /NEA 04b/, /NEA 07/. In addition to the workshops a questionnaire was circulated to AMIGO participants to capture elements of practical experience and to collect together current geoscience knowledge and reasoning that supports a safety case. The results of this initiative are documented in the AMIGO compendium /NEA 08d/. The German side participated with a common contribution of BfS, BGR and GRS. The main results of the whole AMIGO project are summarised in the following.

3.3.1 Building confidence using multiple lines of evidence

During the process of making a safety case multiple lines of evidence by underlying quantitative and qualitative arguments related to the long-term behaviour of the geosphere are used. In the AMIGO compendium over 30 examples from the different participants have been documented that cover experience and practice in sedimentary and crystalline settings. The topics are site-specific and wide ranging, and include groundwater age and residence times, long-term climate perturbations, sorption and matrix diffusion, diffusion dominant transport regimes, preferential groundwater pathways, depth of recharge penetration, geomechanical stability, self-sealing properties, seismicity, erosion and uplift. These examples reveal a commonality in international programs toward the combination of multi-disciplinary evidence to constrain or bound interpretation of geosphere behaviour and to better explain concepts of waste isolation and repository safety. The examples serve the safety case directly, for example by providing information or data for models used in quantitative evaluation of safety, or indirectly, for example by providing evidence to support model assumptions concerning issues such as site stability and integrity of very long time scales.

Usually key elements of the repository safety concept are supported not by a single geoscience observation, but by a number of observations from different disciplines that add to a single important conclusion. Examples are the evidence that a salt dome has been isolated from fluids for millions of years, that oxidizing waters from the surface have not reached repository depths in fractured crystalline rocks, or that radionuclide transport has remained diffusion-dominated, at time frames relevant to safety, in the Opalinus Clay and similar formations. Furthermore, experience has demonstrated that such arguments can provide a more intuitive basis to explain site-specific reasoning to

both scientific and non-technical audiences. The overall outcome has been an enhanced confidence in different safety cases.

One of the most important outcomes from geosynthesis at a potential repository site is information with regard to the past and future stability of the geosphere, for which paleohydrogeologic arguments are vital. It should be recognised that a safety case could be built and defended, if one can supply well-reasoned bounds on future evolution.

Sharing experiences from different programmes is a crucial form of peer review and will lead to improved geoscience arguments and may lead to international consensus on selected topics. In this respect geosciences programmes outside of the radioactive waste disposal such as petroleum industry and academia can be very valuable.

3.3.2 Communication and management

Geosynthesis is the integration of available geoscience information to construct a comprehensive understanding of the geosphere, often documented in a dedicated volume or part of a safety case. The information can be qualitative and quantitative, and typically is derived from many disciplines such as geochemistry, geophysics, hydrogeology, petrography, paleohydrogeology, isotope geochemistry, tectonics, structural geology, and climatology. The understanding leads to a “conceptual model” of the geosphere, and includes information on uncertainties – using different lines of reasoning to constrain possibilities. The model supplies the specialized information and data sets pertaining to the geosphere that are needed for the safety assessment and for the design of the engineered barriers

For the selection and application of information from site characterisation the communication between the participating groups is of utmost importance. Integration groups with geoscientists, engineers, PA modellers etc. are now part of most programmes. Managing integration involves a great deal of communication and coordination within an iterative process, requiring processes to accept input from various technical experts and integration through multi-disciplinary reviews and formal procedures for data management and acceptance. A common terminology used by the specialists involved is crucial for a successful integration. This “human-oriented” integration is followed by “code-oriented” integration, which has greater consistency if

different disciplines use the same core model and database. A co-ordinating group with interdisciplinary skills is needed to direct the integration.

Several important issues to be considered for the communication process – including communication with the public – have been identified within the AMIGO project:

- Different means of communication must be used, but the underlying information must be consistent and based on sound geoscientific understanding. For instance, good illustrations are effective communication tools but they must firmly be based on the science and consistent with related illustrations and figures.
- Good illustrations take time, energy, and clear mental processes to produce.
- Communication processes should involve media people and geoscientists and appropriate training of both groups is recommended. For many audiences, it may be more effective to improve the geoscientists' communication skills rather than to teach geoscience to a communication expert.
- The disposal development programme is a long process that will likely take many decades, from early conceptual studies to decommissioning and closure. Thus there is a need to reach young people, as they will be our decision-makers in the future.
- Communication between implementers and their regulators should start early in the process and might be best served by informal reviews that help to identify and then resolve important issues.
- An effective way to deal with non-unique interpretations is to address each major possibility formally in the safety case.
- A management strategy to deal with public controversy involves preparation of a public report by an independent expert.

3.3.3 Handling of uncertainty

Because of the complexity of several aspects and the inherent nature of the geosphere, the existence and remaining of uncertainties is unavoidable. Uncertainties exist in the raw “point” data, discipline-specific models and the integrated model. All uncertainties must be formally evaluated and documented, using processes such as responding to lists of focussed questions and discussions at interdisciplinary

workshops. Depending on the nature of the uncertainty in question, the result might be alternative conceptual models, probability density functions or other qualitative or quantitative descriptions. Uncertainty might be constrained using multiple lines of evidence and studies of past evolution of the site. Other important factors include feedback from safety assessment and engineering and regulatory context or guidelines.

The site descriptive model represents a current description of the site and there is a need to deal with integration and uncertainty issues that may arise as the system evolves in the future. It was observed that time evolution can be described using scenarios, which should be defined through an integrated, multi-disciplinary process, based on common assumptions, to ensure self-consistency in the scenario descriptions.

Uncertainties are site-specific and originate from the variability in hydromechanical, and geochemical properties and the presence of structural heterogeneities. Another origin of uncertainties is related to the very long time frames considered. It could be useful to split up the evolution in smaller time frames with changing significance and likelihood of different processes and events that need to be considered. The nature of the calculation should depend on the progress of the geological repository programme. In the first steps of the programme, when acquisition of knowledge is limited and based on general description of FEP or generic data, the deterministic approach, associated with conservative assumptions and parameters, seems to be the most relevant. This approach does not exclude the use of a probabilistic analysis to treat parameter variation. But, at this preliminary step, one limitation relies in possibly masking of the influence of parameter variation due to the use of conservatism. At a more evolved stage of the programme, when knowledge is improving (and allows iterative safety assessment between main phases of the programme, a more realistic performance assessment is necessary. Combined with this more realistic data and processes, the probabilistic approach appeared to be more relevant. But it should be underscored that the intensive use of probability density functions requires sufficient data collection.

3.3.4 Iteration between safety strategy, design and site characterisation

The iterative process of reviewing, aiming at ensuring the consistency between safety strategy, design, and site characterization is an efficient way of focusing R&D studies

on priorities. Examples are (1) the drill of boreholes in order to check the existence of fractures in the Callovo-Oxfordian formation, (2) the impact of gas production in salt rock, and (3) the improvement of the groundwater model in the Parisian basin by accounting salinity concentrations in the model. This reviewing cycle is first the responsibility of the implementer but it is also on the basis of periodic review and interactions between implementers and regulators. Different review cycles and R&D programmes are adapted to the different stages of a program with the view to structuring the communication of the geoscience understanding between the different parties. But in order to really improve the cycled review and dialogue between the implementer and the regulatory (or the technical support organization), there is a necessity for regulators and the technical support to develop their own scientific skills. In particular, development of independent experimental and modelling capabilities allows supporting requirements and assessing the approaches and R&D programme proposed by the operators.

3.4 NEA-Working Group Timing of High-level Waste Disposal

The NEA-committee for „Technical and Economic Studies on Nuclear Energy Development and the Fuel Cycle“ (NDC) decided to provide a comprehensive overview over the decision processes related to the disposal of high level radioactive waste in each member country. Within that frame, the particular aspect of the timing of the disposal of high-level waste has to be addressed to. Here, “timing” means the programme of successive actions to be undertaken with a view to stepwise licensing, construction, operating, and closing a final disposal facility for high-level waste.

For that an ad-hoc working group of experts was installed under the auspices of the NEA in which the GRS participated. Further participants were delegated from Belgium, the Czech Republic, Finland, France, Japan, South Korea as well as the European Commission and the IAEA. This working group produced a study aiming at identifying and assessing the impacts of technical, economic social and political factors on timing of HLW disposal programmes through analyses of several country cases /NEA 08c/.

The working group considered timing as an important issue for all countries with an existing nuclear power programme, whether or not it is intended that nuclear power should be phased out or expanded – the waste already exists and must be managed in

any case. It is equally important for countries planning to start a nuclear power programme.

On the international level, it is widely believed that long term management of high-level wastes should be based on deep geological disposal. On the one hand, considerations of security and inter-generational equity suggest that geological disposal should be implemented as soon as possible. On the other hand, many opponents argue that there has been insufficient demonstration of the long-term safety of deep geological disposal and also argue that there should be a moratorium on building new nuclear power plants (NPPs) until the issue of long-term management of HLW is resolved. These arguments have a powerful influence on public opinion towards both the construction of a waste repository and the building of new NPPs.

The study revealed a wide range of factors which affect the timing of HLW disposal. It examines how social acceptability, technical soundness, environmental responsibility and economic feasibility impact on the timing of HLW disposal and can be balanced in a national radioactive waste management strategy taking the social, political and economic environment into account. It shows examples of strategic responses to public concerns and requirements regarding a national radioactive waste management approach.

As a conclusion the study emphasises that regardless of whether national policies are to phase out or continue with nuclear power, repositories for the disposal of HLW will be needed to deal with existing wastes. If demand for nuclear power expands globally, even further efforts are needed to implement HLW disposal. A key challenge for the nuclear industry is timely implementation of final disposal, and at the same time achieving the necessary public acceptance through participation in an open and transparent decision-making process.

The analyses of public polls carried out within the EC lead to the conclusion that public concern with respect to radioactive waste disposal is a key factor in reducing public support for nuclear energy in general. One of the major factors dictating the long timescales for achieving final repositories is a lack of further improving public trust and confidence, and of public involvement in the selection of the proposed solutions. If governments wish nuclear energy to be part of their energy mix, their publics need to be much better informed with respect to the issues surrounding

radioactive waste management and disposal. As long as a significant fraction of the public continues to hold misconceptions on radioactive waste management, public opinion will continue to cause delays in HLW disposal programmes.

The analysis of the international projects to implement a high-level waste repository highlighted the importance of stakeholder issues at all levels, and that no longer the technical issues can be regarded as the dominating factors. A majority of the public, in countries with and without nuclear power, believe that there is currently no safe solution for radioactive waste disposal. This indicates that confidence in scientists and experts still has to be built and that further efforts in communication are required. It may also indicate that the public has high expectations from innovative techniques yet to be invented or developed.

The development of the technical and scientific case for a repository is obviously the other key area that demands a significant timescale. The safety case for a HLW repository is of the utmost importance and the needed research efforts are extensive and time consuming. Further, it must be assumed that in an open society the final selection of a disposal concept and of a site will be challenged by stakeholders from every possible angle. Strong arguments must be available to show that the optimal overall choice has been made from a safety point of view as well as from the technical, economic and social viewpoints. Extensive scientific and technical background material will give a solid basis for the arguments in this discussion. The trend is that the public dialogue and the decision-making process are becoming increasingly important and the time needed should be considered and not underestimated.

The expert group drew the following overarching conclusions /NEA 08c/:

- It seems to be a generally agreed principle amongst the industry, the public and politicians that each generation that benefits from nuclear power should honour its responsibilities and should deal with its radioactive waste in a manner that protects human health and the environment, now and in the future, without imposing undue burdens on future generations. This ethical principle of "intergenerational equity" is a driving force to avoid undue postponement of HLW disposal.
- There is a broad agreement among experts that deep geological disposal is technically feasible and constitutes a safe option for the relatively small volumes of HLW compared to other toxic waste types.

- Interim storage of HLW could continue for many more decades, provided that proper controls and supervision continue. However, this can only be an interim solution; at some point a final disposal solution must be implemented.
- The general political climate regarding nuclear issues, and political stability and continuity of decisions already made on principles and time schedules, will influence the views of the general public and its confidence in the decision-making process and thereby the timing of the implementation of HLW disposal.
- There is clear evidence that significant fractions of the public still have serious misconceptions with respect to the issues surrounding nuclear waste. The nuclear industry, together with governments in those countries who would like a component of nuclear power in their energy mix, has a responsibility for and a significant challenge in presenting its case to the public. A number of OECD governments (e.g. France, Germany, Japan, Republic of Korea, United Kingdom), are undertaking public consultation exercises as part a wider process of establishing a consensus.
- Opponents to nuclear energy often claim that further expansion of nuclear power would drastically increase the radioactive waste problem. Since the generated volumes are small and a timely implementation of HLW repositories will still be needed for already produced quantities of HLW, irrespective of any future expansion of nuclear power, this argumentation is considered spurious.
- If terrorist and proliferation risks are high on the political agenda these may act as new driving force in the implementation of HLW disposal systems.

The following issues are considered to be of highest importance for timing of HLW disposal /NEA 08c/:

- Most countries already have well developed waste management programmes with time schedules for disposal implementation. However, experience has shown that, in practice, the time schedules originally envisaged prove to be ambitious. This is driven by the twin factors of the scientific detail needed to prove the choice and the technical acceptability of a chosen site, and the time taken to gain public and political acceptability for the outcome choices.
- The availability of suitable host geological formations and the number of potential sites are generally good in most countries and are not a limiting factor for timing from a technical view point. Technically matured disposal systems, comprising

sites, civil works and waste packages, each contributing to the functions required to ensure short and long term safety, are developed in several countries and are generally not a limiting timing factor. However, the societal and political acceptance of these systems is currently the limiting factor for implementation in most countries.

- The clear commitment and support of successive governments towards a national radioactive waste management programme will help its timely implementation and are important factors in reaching a publicly acceptable disposal solution.
- Clear legislation and well-defined roles of the actors in the decision-making process at the local, regional and national levels are key factors in a successful and timely HLW disposal programme.
- The structure and transparency of the decision-making process and the level of and possibility for public participation are key issues for achieving public acceptance. Much progress has been made in developing stakeholder dialogue and transparent public consultation. This work is time consuming and has a large impact on the timing of HLW disposal.
- The level and availability of funds can influence the timing of HLW disposal. All countries considered have arrangements for collecting the appropriate funding from the waste producers to ensure this does not become a limitation.
- The availability of skilled staff should be planned over the implementation period to avoid unnecessary interruptions in what has become a very lengthy process in many countries.
- International cooperation can shorten the time needed in the implementation process by avoiding duplication of research and sharing lessons on stakeholder engagement.
- R&D on new technologies has the expected potential of significantly reducing the quantities of long-lived radioactive waste resulting in reduced volumes for disposal in a repository. It also holds appeal to people who are unconvinced by current proposals for deep geological disposal and are especially concerned about the long lived isotopes. This may be a driver for delay in progressing with a repository. R&D into partitioning and transmutation is not simply a response to public concern. It is part of a responsible and ethical approach towards good resource management, i.e. sorting, recovery, recycling and therefore resource saving.

However these technologies need significant development and time before they are deployable at a commercial scale. Geological disposal of currently vitrified wastes and of fission product wastes will still be needed, even in the event of successful commercial deployment of partitioning and transmutation technologies.

3.5 NEA Sorption project

Accordingly, the overriding objective of the NEA Sorption Project has been to demonstrate the potential of thermodynamic sorption models for improving confidence in the representation of radionuclide sorption in the context of radioactive waste disposal. This objective will be met if:

- It can be shown that the major physical-chemical mechanisms underlying the sorption of a radioelement on different types of solid materials are understood and how sorption intensity is affected by changes in geochemical conditions
- It can be demonstrated that, using models which reflect this understanding, it is possible to represent changes in K_d with reasonable accuracy as a function of variations in relevant system parameters (pH, ionic strength, CO₂ partial pressure, etc.).

To test different surface complex models with the help of benchmark calculations and to use these data for the mechanistic description of sorption for a broad range of geochemical conditions was the most important objective of the NEA Sorption Project Phase II. These activities represent the basis for reducing uncertainties for distribution coefficients and for increasing confidence in modelling sorption processes in long-term safety analyses. The thermodynamic sorption models tested in phase II were able to reproduce the trends, and in most cases the magnitude, of K_d in experimental data, over a very wide range of simple to complex mineral substrates and aqueous chemical conditions (pH, carbonate concentration, etc). The unique ability of the TSMs to explain and predict radionuclide sorption data under various chemical conditions was demonstrated. The final report was published in 2005 /NEA 05/.

To conclude the successful NEA Sorption Project Phase II, topics were identified which seemed sensible for further development on an international level. In particular, Phase II showed clearly that modelling personnel and their decisions and preferences have a major influence on model design and performance. Another important issue already

brought up in Phase I of the NEA Sorption Project is that much of the usefulness and credibility of TSMs depend on an internally consistent and transparent decision-making process during model development.

To address the needs identified in Phase II, it was proposed to develop and publish a guiding document regarding TSM development and use within the framework of PA/safety case building, where the critical issues are treated in a way that will facilitate communication with waste management organisations as well as regulatory authorities. After appraisal by the IGSC, Phase III of the NEA Sorption Project was started in 2007.

The guidelines will contain the following individual topics:

- general strategies and decisions during the development of thermodynamic sorption models,
- identification of decisive model parameters by sensitivity analyses and assessment of uncertainties,
- methods for determining fundamental model parameters,
- development of a scientific basis for application of TSM models and parameters to PA-relevant sorbents, and
- recommendations for best practice.

The project is envisaged to run over 30 months, i.e. a final report is expected for 2010/2011.

3.6 Clay-Club

A wide spectrum of argillaceous media are being considered in NEA member countries as potential host rocks for the final, safe, near-surface or at-depth disposal of radioactive waste, and/or as major constituents of repository systems in which waste will be emplaced. These media have a number of favourable generic properties, such as homogeneity, low groundwater flow, chemical buffering, a propensity for plastic deformation and self-healing of fractures by swelling, and a marked capacity to chemically and physically retard the migration of radionuclides.

In this context, the NEA established in 1990 a Working Group on Argillaceous Media, known informally as the "Clay Club".

The Clay Club examines those various argillaceous rocks that are being considered for the deep disposal of radioactive waste, ranging from soft clays to indurated shales. These rocks exhibit a wide spectrum of characteristics which make them useful as barriers to the movement of water and solutes and as repository construction materials. Studies include clay media characterisation and modelling.

Three key initiatives have now been completed:

- The Feature, Events, Processes catalogue: Argillaceous media (the FEPCAT report) is now available. The Clay Club acknowledges the limitation of the database in time: and in particular that the recently published reports are not formally included.
- A catalogue of characteristics. The catalogue consists of a brochure and a CD-ROM containing all data tables in Excel format.
- The self-healing study that aims to establish a state-of-the art document on the self-healing of clay media is currently being finalised.

Initially, the Clay Club launched a compilation and review of the relevant literature on the basic concepts and mechanisms which control the movement of water, solute and gas through the whole spectrum of argillaceous media being considered for radioactive waste disposal. Subsequent work has included an examination of fluid flows through faults and fractures in argillaceous formations and the complex question of extracting solutions from them. The fluid flow research has also included an evaluation of the advantages and limitations of current approaches.

The "Clay Club" launched the FEPCAT (Features, Events and Processes CATalogue for argillaceous media) project in late 1998. The FEPCAT project aims at providing, for each FEP, a critical overview of conclusions and key references related to its current understanding and its potential impact on the long-term performance of the geosphere barrier, and information on ongoing and planned work. Experimental information (field, laboratory, numeric) provided by the funding organisations was the primary source of data.

The main objectives were as follows:

- To derive a list of FEPs which are specific to argillaceous media. Only FEPs deemed relevant were to be included.
- To provide an overview of past, ongoing and planned *in situ* and laboratory experiments.
- To make a link between site investigations and their application in performance assessment, and to provide a scientific background for the assessment of geosphere performance.
- To define future priorities with regard to a better understanding of argillaceous media.
- To define terms whose connotation is different in different countries or scientific disciplines, and to link the radwaste terminology to general scientific usage.

The present document provides the results of work performed by an Expert Group to develop a FEPs database related to argillaceous formations, whether soft or indurated. It describes the methodology for the work performed, provides a list of relevant FEPs, summarises the knowledge on each of them, gives general conclusions and identifies priorities for future work /MAZ 03/.

The “Clay Club” examines the various argillaceous rocks that are being considered for the deep geological disposal of radioactive waste. Considering its overall objectives, one of the first initiatives of the Clay Club was to gather in a structured way the key geoscientific characteristics of the various argillaceous formations that are – or were – studied in NEA member countries with regard to radioactive waste disposal. The effort resulted in an internal catalogue of characteristics in the beginning of the 1990s. After several internal updates (1995 and 1998) and restructuring resulting from end-users’ feedback, the NEA Clay Club considered it necessary and timely to prepare an open version of the catalogue /BOI 05/.

The Clay Club initiative on long-term natural tracers profiles (CLAYTRAC), completed the data collection stage of the project in late 2006. The project aims to provide an overview of available data sets regarding long term natural tracers’ profiles. The added value of that work compared to studies dealing with individual sites in isolation lies in

the comparison and integration of data, results and conclusions from a variety of sites and formations. A publication for the final report is planned in the end of 2008.

In the work carried out so far it is shown that:

- self-sealing in argillaceous materials remains a major concern;
- there is substantial new and specific information on the self-sealing topic since the BGS draft report of 2005;
- the processes leading to self-sealing are not yet fully understood, but distinct processes have been identified (e.g. accelerated creep during water take-up, swelling, load-dependent aperture change and disintegration);
- there is a reasonable body of information on the self-sealing topic available, however, that information is unsystematic and rather dispersed.

The project occurs to be warranted. It is recommended to go ahead with the elaboration of a Full Report and to set the date of submission of the Full Report to the annual Clay Club meeting of the year 2008.

The clay club agreed on a way forward. Major future activities are briefly described in the following.

Faulting and Fracturing at Depth: For this topic a workshop is organized in the frame of the conference: "Fault Zones - Structure, Geomechanics and Fluid Flow on 16.-18. September 2008, in London. Faults play a crucial role in controlling strain accumulation in the Earth's crust. At the largest scale they control the form and evolution of sedimentary basins and at the smallest scale. The development of fault zones results in a change in the mechanical and hydrological properties of the fault rocks, thereby impacting on their mechanical strength and permeability. With recent advances in subsurface, modelling and field-based studies, this conference aims to bring together a diverse range of scientists interested in fault growth, fault zone properties and their effects on other processes such as fluid flow and earthquake processes.

Gas generation/migration: It is a major issue in all clay programs and there is a need to develop an understanding, what are the real implications for host rock performance and safety over the long term. It needs to be analysed, what are the experiments or other actions to be taken to fill the gaps and build confidence. In order to address these

questions a workshop on clay and EDZ is planned. Synergies with the EC (state-of-the-art through concerted action) and IGSC initiatives (proposed IGSC workshop in 2010, see chapter 3.2.4) should be regarded.

Diffusion: For this topic a workshop is planned to combine information on relevant aspects of pore space characterisation and up-scaling, in particular progress in molecular modelling. This should provide the basis to gather information for a state-of-the-art report concerning clay rock.

Alkaline Plume: For this topic a workshop is planned to identify, how coherent we are in our understanding and how could be moved forward to make a stronger case considering long-term effects and couplings (porosity reduction). It is not the objective to focus on experimental or modelling details, but on questions as “what is the role/effects of simplification in PA” and what is relevant in natural analogues, experiments, and models to be used in PA”. The outcomes of the EC project NFPRO will be taken into account and synergies are expected with the IGSC project on Cross-Cutting Issues, where cementitious materials are a possible topic for a workshop in 2009 (see chapter 3.2.4).

3.7 FUNMIG

The European integrated project (IP) “Fundamental process of radionuclide migration” (FUNMIG) is carried out within the 6th framework programme and deals with radionuclide migration in the host rocks and in the overburdens of potential host rock formations foreseen in different European programmes for repositories for disposal of radioactive waste. IP FUNMIG is a four-year project and started on January the 1st 2005.

The project includes six Research and Technological Development Components (RTDC's):

- RTDC's 1 and 2 activities are focused on conceptually well defined (RTDC 1) and conceptually less established processes (RTDC 2), not oriented towards a specific host-rock type or disposal concept. While RTDC 1 aims to fill in critical data gaps, especially in thermodynamic data for speciation and sorption, RTDC 2 is more addressed to deepen the understanding of conceptually less understood

processes. Examples for the work performed in RTDC 2 are colloid-facilitated transport and biochemical processes.

- RTDC's 3 to 5 focus on processes of relevance in the three main types of host rock considered in the European countries, which are: clay (RTDC 3), crystalline (RTDC 4) and rock salt (RTDC 5). In contrast to clay and crystalline, where the work focuses on the transport in the host rock itself, the work in RTDC 5 for salt refers to the overburden far-field on top of the salt rock formation, and is restricted to the investigation of speciation processes in a natural analogue study.
- The task of RTDC 6 is to evaluate the work performed in the five scientific RTDC's in terms of the use of results in performance assessment and the safety case. While the synthesis of the project results is done within three host rock specific RTDCs, RTDC 6 brings together the leaders of the scientific RTDCs with end-users from the Waste Management Organisations (WMOs) representing the different host rock types.

As part of the project WiGru the GRS participated in RTDC 6 of FUNMIG and acted for the WMO representing the salt host rock.

The idea behind the work performed in RTDC 6 was to create guidance for the scientists about what are the needs by the performance assessors. This was achieved in terms of host rock specific "Task Evaluation Tables" (TETs). All topics dealt with in FUNMIG were broken down to the single task level within each RTDC. Each single task was mapped on internationally accepted FEP (Features, Events and Processes) lists or views. For salt host rocks a far-field subsection of the FEP list developed in the German research project ISIBEL was used.

A procedure was developed to judge the tasks and results with respect to their impact on Safety Assessment. The WMOs were asked to give a rating for each task regarding different indicators such as the relevance of the task for Safety Assessment, its potential to reduce the uncertainty of safety assessment parameters and the benefits of expected improvements. The answers were given in pre-defined qualifiers like "must have" for high priority or "irrelevant" for a very low priority. Additional information could be given by selecting combinations of additional qualifiers like host-rock specific or site-specific etc. The task evaluation table for the salt-specific tasks of RTDC 5 are given in Tab. 5 as an example. The different possible qualifiers are given in the second row of the table. The full task evaluation table for all tasks of FUNMIG is given in reports from NAGRA /NAG07/ and FUNMIG deliverable PID6.2.1. The excerpt of the full TET given

in Tab. 5 refers to the current state of the table as given in the referenced report. A final version of the TET will be given at the end of the project FUNMIG and will be published in an updated version of the report.

For salt host rock, the rating was applied somewhat different than for the other host rock types, because the normal evolution scenario of a repository in rock salt is characterised by a complete sealing of the wastes in the salt, i.e. in contrast to the clay-rich and crystalline host rocks, a release of radionuclides to the far-field is not expected for the normal evolution of a repository in rock salt. Therefore, the far-field processes listed in the task evaluation tables are not relevant for the normal evolution scenario and can be regarded only for those altered evolution scenarios of the waste repository which lead to a release of radionuclides into the far-field. Potential altered evolution scenarios are e.g. the early intrusion of brines through a failed shaft seal or the intrusion of brines from undetected large-volume brine inclusions in the salt formation.

Since the probability of occurrence of an altered evolution scenario itself is already low, the relevance of all processes listed in the task evaluation table could also be referred to as being low with respect to the whole safety assessment of a repository in rock salt formations. To avoid the loss of significance involved in an approach like this, the ratings were determined only with regard to their relevance for the altered evolution scenario, not for the overall safety assessment.

No up-to-date probabilistic assessment of the far-field parameters existed at the time of creation of the TETs for those altered evolution scenarios considered for a repository in rock salt formations today. Therefore, the experience from over 20 years in safety assessments for repositories in salt formations was used by the GRS for an expert judgement of the ratings of the columns "Relevance of SA" and "Influence of investigated process on SA parameter uncertainty". As noted above, the properties of the far field of a waste repository in salt formations depend on the type of overburden over the salt dome and are therefore in most cases highly site-specific. As a consequence, the rating "site-specific" is given for most of the parameters in the "Relevance of SA" column.

Tab. 5 Task evaluation table for the salt-specific tasks

FUNMIG Tasks		Relevance for SA	SA parameter	Influence of process on SA parameter uncertainty	Relevance of SA parameter uncertainty	Benefits of improvement
Possible qualifiers that could be given for each of the tasks below:		<ul style="list-style-type: none"> - must have - should have - nice to have - irrelevant optional: <ul style="list-style-type: none"> - site-specific - inventory-spec. - design-specific - demonstrating process understanding - enhancing process understanding - basis for deriving SA parameter values 	examples of SA parameters: sorption coefficient, solubility limit, porosity, diffusion coefficient etc.	<ul style="list-style-type: none"> - strong - medium - low - non-existent - not applicable 	<ul style="list-style-type: none"> - high - medium - low - irrelevant - not applicable 	<ul style="list-style-type: none"> - strong - medium - low
WP 5.1 Determination and characterization of colloids under variation of geochemical conditions						
5.1.1	Geo-monitoring of groundwater under undisturbed conditions	- should have	Base for Retention factor R	not applicable		medium
5.1.2	Interpretation of results with regard to colloid stability in natural systems	<ul style="list-style-type: none"> - should have - basis for deriving SA parameter values 	Base for Retention factor R	medium	medium	medium
WP 5.2 Geochemical behaviour of radionuclides in the natural host rock						
5.2.1	Natural sample characterisation by μ -spectroscopical multi method strategy	<ul style="list-style-type: none"> - nice to have - site-specific - enhancing process understanding 	C_{sol}	medium	low	medium
5.2.2	U(IV) / U(VI) separation	<ul style="list-style-type: none"> - nice to have - site-specific - enhancing process understanding 	C_{sol}	medium	low	medium
5.2.3	Extraction experiments	<ul style="list-style-type: none"> - nice to have - site-specific - enhancing process understanding 	C_{sol}	medium	low	medium
5.2.4	Uranium desorption experiments	<ul style="list-style-type: none"> - should have - site-specific - enhancing process understanding 	K_d, C_{sol}	medium	medium	medium
5.2.5	Uranium adsorption experiments	<ul style="list-style-type: none"> - should have - site-specific - enhancing process understanding 	K_d	medium	medium	medium
5.2.6	Synthesis	- should have	K_d, C_{sol}	medium	medium	medium

FUNMIG Tasks		Relevance for SA	SA parameter	Influence of process on SA parameter uncertainty	Relevance of SA parameter uncertainty	Benefits of improvement
WP 5.3 Real system analysis						
5.3.1	Isotope geochemical characterization of Ruprechtov site	no SA relevance				
5.3.2	Inverse modelling	no SA relevance				
5.3.3	Description of behaviour of organic matter at Ruprechtov site	<ul style="list-style-type: none"> - should have - site-specific - enhancing process understanding - basis for deriving SA parameter values 	Base for K_d , C_{sol}	medium	medium	medium
5.3.4	Application of geochemical models to the natural system at Ruprechtov site	<ul style="list-style-type: none"> - should have - enhancing process understanding 	K_d , C_{sol}	medium	medium	medium
5.3.5	Description of behaviour of uranium in the natural system at Ruprechtov site	<ul style="list-style-type: none"> - should have 	K_d , C_{sol}	medium	medium	medium

4 Selected topics

4.1 Safety analyses for Clay formations

4.1.1 Gas generation and transport

Gas transport phenomena in clay material related to nuclear waste disposal in deep geological formations have been intensively studied since clay has become a quite common material in many repository concepts. This is on the one hand as bentonite or bentonite/sand mixtures being used as engineered barrier material for seals, buffers and backfills in all type of host rock formations and on the other hand as host rock formation itself. The first studies started mainly for bentonite used as buffer material in waste repositories in crystalline rock and for plastic clays considered as host rock formation in Belgium. The research was once more extended as consolidated clay formations were considered as host rock formations in Switzerland (Opalinus Clay) and France (Callovo-Oxfordian); many new experiments were started in the underground research laboratories of the respective formations in Mont Terri and Bure.

Since a few years consolidated clay formations also came in the focus as potential host rock formation in Germany, namely Opalinus Clay in Southern Germany and Lower Cretaceous Clays in Northern Germany. The project TONI, which developed tools for performance assessment for a repository in clay in Germany, did not yet include gas transport /RUE 07/. Therefore, the state of research for gas transport in consolidated clay formations was reviewed as a part of this project, especially with regard to performance assessment to give recommendations about the necessity to develop performance assessment tools considering the gas transport.

The following section shortly summarises the main aspects of importance for gas production in a repository in clay. The further sections characterise the different gas transport processes in clay formations and their experimental evidences, and finally give a recommendation of further action to develop tools for performance assessment.

4.1.1.1 Gas generation

Regarding the gas generation in a repository for high level waste it has mainly to consider the generation of hydrogen gas forming by anaerobic corrosion of iron. Iron is emplaced in the repository in a large amount as component of the waste containers.

The anaerobic corrosion of iron takes place in a two step process: First, the iron is converted into Fe(II)oxide, which will be subsequently converted into magnetite. The anaerobic corrosion process of iron can only take place if sufficient water is available. For the complete conversion of iron to magnetite 0.43 kg of water are necessary per kilogram of iron. Under the assumption of a radial flux towards the container, the water flux was estimated in /RUE 04/ to be 2.6 kg/a. This number might overestimate the realistic value since this estimation did not take thermal effects into account. However, it can be assumed that the supply of water always exceeds the consumption by corrosion and the corrosion rate as well as the absolute amount of produced gas is only limited by the availability and the type of the iron in the repository. If the iron is completely converted into Magnetite, 23.876 Moles¹, i.e. 0.535 m³ of hydrogen gas at normal pressure are generated per kilogram of iron.

A repository in Northern German clay formations like the Apt of the Lower Cretaceous Clay sequence would be constructed in a depth of at least 400 m below surface. At a typical rock pressure of 8.6 MPa in a repository depth of about 400 m, the volume of hydrogen gas produced per kilogram iron corresponds to 6.22·10⁻³ m³. Regarding the types of containers being in discussion to be used in the German repository concept, the CSD-V container for vitrified HLW or the Pollux and BSK-3 containers for spent fuel, the total amount of hydrogen produced under rock pressure is about 0.5 m³ for CSD-V container with a weight of 75 kg, 360 m³ for Pollux container with a weight of about 58 t and 15.5 m³ for a BSK-3 container with a weight of about 2.5 t. In the case of spent fuel additional gases will be produced depending on the loading by the metal parts of the waste inside the containers.

The corrosion rate of iron was examined in in-situ experiments as well as in laboratory experiments by /SMA 95/. For highly saline NaCl brines as they are expected in the deep hydrogeological formations in Northern Germany a corrosion rate of 5 µm·a⁻¹ was

¹ A molar weight for iron of 55.845 g/mol was used for the conversion

determined at a temperature of 90°C. For the demonstration of disposal feasibility for spent fuel in the Opalinus Clay by NAGRA a reference value for the corrosion rate of $1 \mu\text{m}\cdot\text{a}^{-1}$ was used.

For CSD-V container with diameter of 0.43 m, length of 1.34 m and iron density of $7\,800 \text{ kg/m}^3$ the corrosion rate leads as a first approximation to an annual consumption of iron of $7.06\cdot 10^{-2} \text{ kg}$ per container, i.e. the iron is completely corroded after about 1 000 years. This corrosion rate corresponds to an annual gas production rate per container of 1.264 mol per year, i.e. $3.78\cdot 10^{-2} \text{ Nm}^3$ or $4.4\cdot 10^{-4} \text{ m}^3$ gas at rock pressure.

The surface of a Pollux container is about 14.62 times the surface of a CSD-V container resulting in a higher initial gas production rate by the same factor of about 18.48 mol per year, i.e. 0.414 Nm^3 gas per year. This gas production rate decreases with time as the surface of the container decreases.

Three additional processes might contribute to the gas generation to a certain extent: The first one is the corrosion of organic substances emplaced with the waste. The amount of organic substances in the repository is highly dependent on the repository concept, the type of waste and the type of the waste package. No major amounts of organic material are expected in a repository for high level waste in Germany. Therefore, it is not discussed further.

The second process is the radiolysis of water by radiation from the nuclear waste. The gas amount generated by radiolysis of water is estimated in /RUE 04/. For the direct disposal of thin walled HAW canisters in bentonite, up to 140 Nm^3 of hydrogen gas is produced per metre of canister length. This amount is however considerably reduced if containers with thicker walls shielding the radiation are used. No radiolysis is expected from spent fuel, which is emplaced in Pollux containers.

Recent studies have shown that bentonite used as backfill material in repositories in clay contains considerable amounts of extractable CO_2 adsorbed on inner surfaces /JOC 08b/. In the current state of knowledge it is unclear whether the CO_2 might also be released from the bentonite under repository conditions or not. For a quantitative estimation, this process has to be further investigated.

4.1.1.2 Gas transport in clay formations

The driving force for the gas transport is the pressure build-up from gas generation. In the void volume in or around the container a gas pressure develops according to the amount of the generated gas as given above. In water saturated clay formations the following processes can lead to gas transport and to dissipation of the gas pressure:

- dissolution of gas in the pore water and subsequent transport in the dissolved state by diffusion or by advection with water flow,
- advective flow of gas in volatile form in the pore space of the clay which gets partially desaturated (two-phase flow) and
- flow of gas on newly created pathways which form as a consequence of the high gas pressure. Depending on the gas pressure, these pathways might either be created by pore space widening (dilatation) without disturbing the pore structure of the clay or by fracturing and disturbing of the pore structure.

These three types of gas transport are described in the following. The schematic insert illustrations representing the individual gas transport phenomena were taken from the ANDRA safety case "Dossier Argile" /AND 05/.

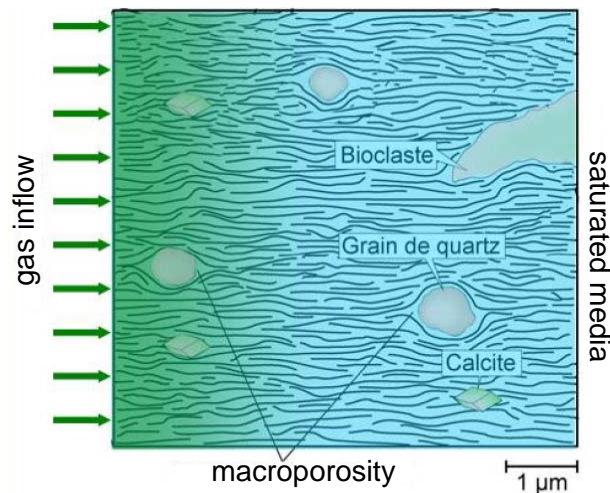

Fig. 15 Diffusion of dissolved gases

A fraction of the gas can be dissolved in the pore water of the clay formation corresponding to its gas solubility. It can be transported by diffusion or by advection if gas will be transported with the water flow. However, the transport of dissolved

hydrogen is limited due to the following reasons: first, by the low solubility of the hydrogen gas in the pore water and second, by the low permeability of the clay formations which results in a low advective flow of the water.

The advective flux of gases dissolved in the water is given by the product of the solubility $K_{H,cp}$ with the advective water flux \mathbf{Q} according to Darcy's law:

$$\mathbf{Q} = -A \frac{k}{\mu} \nabla p \quad (4.1)$$

in which denotes

A cross sectional area,

k permeability,

μ viscosity of the fluid and

p pressure, e.g. hydraulic pressure and/or gas pressure.

The diffusive flux \mathbf{j} evolving from the concentration gradient of the dissolved gases can be determined by Fick's first law:

$$\mathbf{j} = -n_{diff} D_p \nabla c. \quad (4.2)$$

in which denotes

n_{diff} diffusion accessible porosity,

D_p pore diffusion coefficient and

c concentration of the gas dissolved in the pore water.

For modelling the diffusive gas transport, the diffusion coefficient and the accessible porosity for the dissolved gaseous species are usually chosen the same as for electrically neutral species. The concentration c of a gas dissolved in the pore water is determined by Henry's law of solubility:

$$c = K_{H,cp} P_{gas} \quad (4.3)$$

in which denotes

p_{gas} partial pressure of the gas in the gaseous phase and

$K_{H,cp}$ Henry coefficient in $[\text{mol}/\text{m}^3/\text{atm}]$.

This implies that the concentration of the gases in the liquid phase increases with gas pressure; when the gas pressure is in equilibrium with the hydrostatic or rock pressure the concentration also increases with the repository depth. The solubility of Hydrogen in water is about $K_{H,cp} = 0.8 \text{ mol}/\text{m}^3$ at normal pressure which corresponds to a solubility under repository conditions at a rock pressure of 8.6 MPa of about $70 \text{ mol}/\text{m}^3$. For the amount of gas generated by the full corrosion of a CSD-V container about 25 m^3 of pore water are needed to dissolve all the gas that means about 170 m^3 of rock if a porosity of 0.15 will assumed. For a Pollux container the rock volume needed to dissolve all the gases would be about $132\,000 \text{ m}^3$, that means a cube with 50 m edge length.

The absolute amount of gases and the gas production rates in waste repository concepts based upon the storage of iron containers are usually high and exceed the maximum dissipation rate by diffusion by far; therefore, only a small fraction of the produced gas can be removed by diffusion and the gas pressure in the emplacement areas is continuously rising with the gas production rate. To remove the gas from the emplacement areas, other processes have to be more effective to dissipate the gas from the repository.

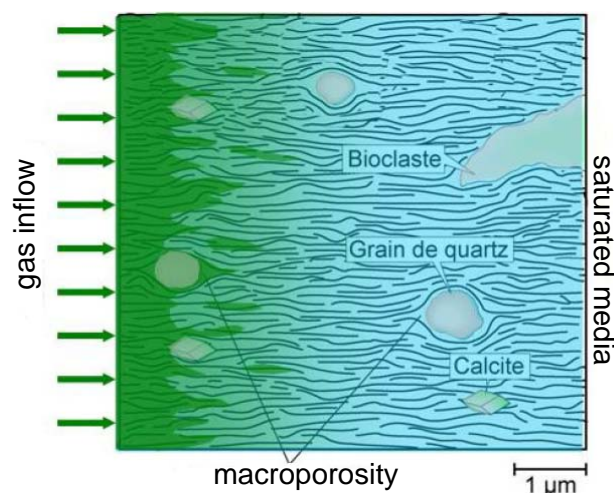

Fig. 16 Two-phase flow

If the gas generation rate exceeds the potential dissipation rate of gas by diffusion in the dissolved state, the gas pressure in the gas phase of the emplacement areas rises continuously. Once the gas pressure in the emplacement area exceeds a certain threshold pressure, the gases can enter into the clay pore space by displacement of water, resulting in a partial desaturation of the clay. While the degree of saturation changes, the porosity of the clay remains unchanged by the entry of the gas into the pore space. The entry of gas into the pore space brings water and gas into joint motion. The simultaneous flow of gaseous and liquid phases is called two-phase flow. In this case, the fluid transport is controlled by three material properties of the fluids and the rock, namely the

- surface tensions of the fluids involved,
- wettability of the solid surface, which is expressed by the wetting angle α and
- the structure of the pore space.

The threshold pressure for two-phase flow, which is in the following called gas-entry pressure p_{ge} , can be calculated for a capillary tube with the Washburn/Young equation according to:

$$p_{ge} = \frac{2\sigma_{gw}}{r} \cos \alpha \quad (4.4)$$

in which denotes

σ_{gw} surface tension gas/water (0.073 N/m at 20°C) and

r pore radius.

The gas entry pressure shows a distinct dependence from the intrinsic permeability, not only for claystones but also for other rocks. Fig. 17 shows the relationship of the gas entry pressure versus intrinsic permeability as received from experiments. For the Opalinus Clay at Benken site the gas-entry pressure was found to be about 5 MPa /NAG 02a/, while the one measured for the Opalinus Clay at Mont Terri was considerably lower /MAR 05/, /ZHA 07/. The gas-entry pressure is typically anisotropic with a lower value parallel than perpendicular to the bedding plane. The gas-entry pressure measured for the Opalinus Clay is in reasonable agreement with the value expected from equation 4.4 and the pore size distribution measured by nitrogen and mercury porosimetry /NAG 02a/. The pore-size distribution shows that 80% of the

pores have a radius less than 25 nm. For a radius of 25 nm a gas-entry pressure of about 6 MPa is calculated for the Opalinus Clay. Compared to the measured value of 5 MPa this indicates that larger pores have a higher impact to two-phase flow than smaller ones.

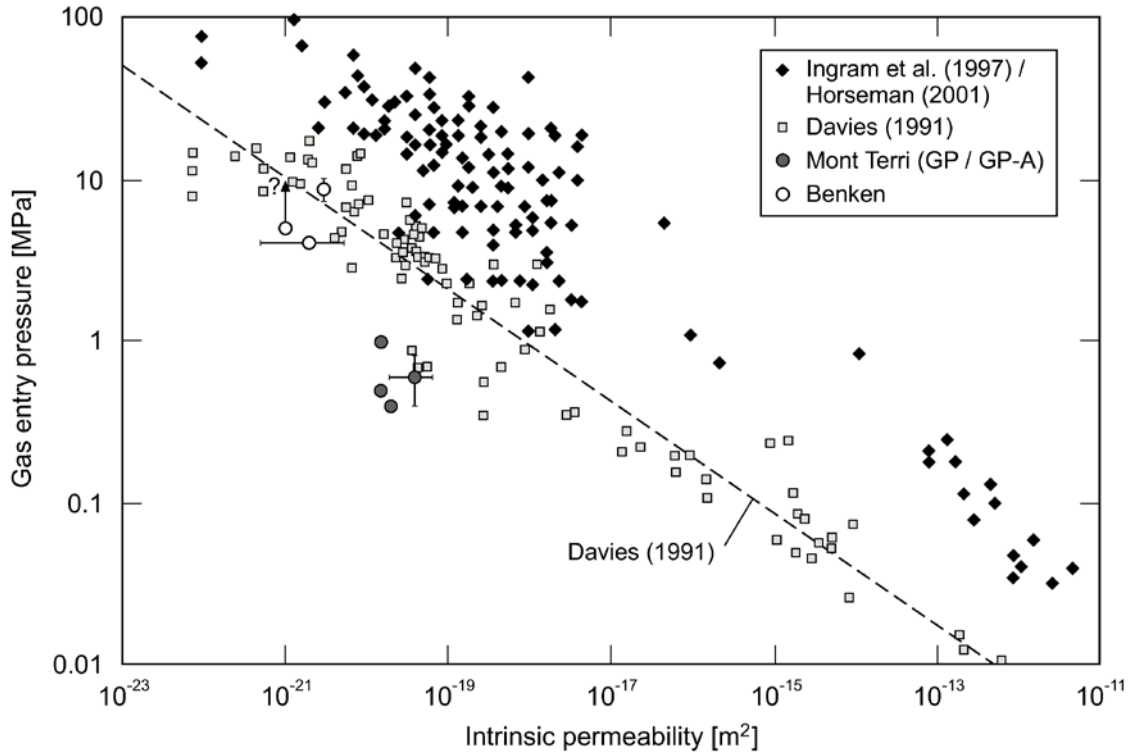

Fig. 17 Relationship between gas entry pressure and intrinsic permeability /MAR 05/.

Two-phase flow is a common phenomenon in soil physics. The flow in partially saturated porous media can be described by the Darcy-Buckingham equation which extends Darcy's law for flow in saturated porous media as given in equation 4.1 with a term taking into account the dependence of the permeability from the saturation:

$$\mathbf{v} = -\frac{k(\theta)}{\mu} \nabla p \quad (4.5)$$

in which denotes

\mathbf{v} Darcy velocity,

$k(\theta)$ permeability as a function of the water content,

θ volumetric water content, i.e. saturation,

p hydraulic potential, which is

$$p = z - \psi \quad (4.6)$$

in which denotes

z hydraulic potential and

ψ suction pressure/capillary pressure.

The crucial point in equation 4.5 is the dependence of the permeability from the degree of saturation, which is usually material dependent and has to be determined from experiments. For a lot of porous media, however, in the soil science curves for this dependency have been determined. Different theoretical models exist to parameterise the permeability as a function of the degree of saturation using only a few model parameters. Common models are the ones by Richards, Brooks-Corey and Mualem-van Genuchten.

The model used in most of the studies for gas transport in clay formations is the one by Mualem and van Genuchten. This model describes the behaviour of the unsaturated porous media by two different functions which are given in the following according to the notation in /POT 02/. The first dependency describes the permeability of the unsaturated porous media in relation to the one of the saturated media (relative gas permeability) as a function of the saturation θ :

$$k(\theta) = k_s \left(\frac{\theta - \theta_r}{\theta_s - \theta_r} \right)^{1/2} \cdot \left(1 - \left(1 - \left(\frac{\theta - \theta_r}{\theta_s - \theta_r} \right)^{\frac{n}{n-1}} \right)^{1 - \frac{1}{n}} \right)^2 \quad (4.7)$$

and the saturation θ as a function of the suction pressure ψ for the case of $\psi \geq 0$

$$\theta(\psi) = \theta_r + \frac{\theta_s - \theta_r}{\left(1 + (\alpha\psi)^n \right)^{\frac{1}{n}}} \quad (4.8)$$

in which denotes

θ volumetric water content

θ_s water content at saturation

θ_r	residual pore water saturation
k_s	permeability at saturation
α	reciprocal of the apparent gas-entry pressure
n	model parameter to be fitted on experimental data.

The pore space cannot be completely filled by water during re-saturation (residual gas saturation). This effect is accounted for with a parameter θ_g where $\theta_g = 1 - \theta_s$.

It is noticed that a critical gas saturation or emergence point in the pore space has to be reached before a continuous gas flow is possible. One characteristic of the model by van Genuchten is the assumption that the suction pressure is vanishing for the saturated state of the medium, i.e. in this case it is $\psi = 0$ and $\theta(\psi) = \theta_s$. As a consequence of this assumption no capillary pressure exists in this model but small desaturation can occur already below the apparent gas-entry pressure, even if it is rather small.

Curves for the dependence of the capillary pressure from the degree of the saturation - also commonly known as sorption/desorption curves or retention curves - have been measured for the Opalinus Clay /NAG 02a/ and the Callovo-Oxfordian Clays /AND 05/ in terms of water adsorption/desorption measurements, mercury porosimetry or suction tests, see Fig. 18 exemplarily for the Opalinus Clay. Significant hysteresis can be seen for the Benken site. Although the occurrence of hysteresis is quite common, it is not well understood. Different reasons are suggested for this behaviour, which are pore connectivity, variability of cross sections and deformation of the rock matrix. Curves shown in Fig. 18 can be fitted by the van Genuchten model to receive the needed model parameters for the desorption path to be $n = 1.6$ and $\alpha = 0.065 \text{ MPa}^{-1}$ and $n = 1.5$ and $\alpha = 0.14 \text{ MPa}^{-1}$ for the adsorption path leading to corresponding apparent gas entry pressure values ($1/\alpha$) of about 7 MPa and 15 MPa, respectively.

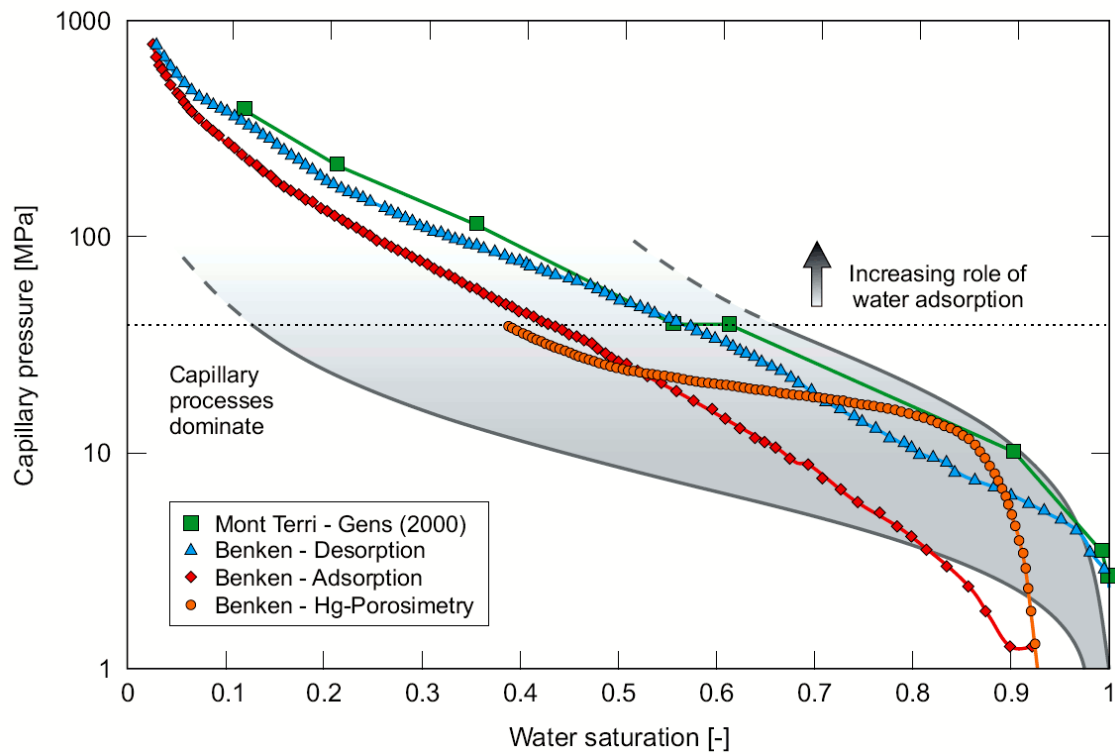

Fig. 18 Capillary pressure versus saturation as measured for the Opalinus Clay at the Benken site /NAG 02a/.

Fig. 19 shows curves obtained from a long-term gas permeability test that has been performed on Opalinus Clay samples at gas pressures being low compared to the confining pressure of 21 MPa in this experiment. The red curve in Fig. 19a shows the gas pressure at the inlet while the blue curve in Fig. 19b shows the gas flow response on the outlet of the sample cell. The experiment shows that an increase of the gas pressure is always followed by quick increase in the gas flow and the gas flow each time reaches a steady state flow corresponding to the gas pressure. The results of an inverse modelling of this experiment with the two-phase flow model TOUGH2 is shown as dotted lines and give a good agreement with the experimental data. The gas-entry pressure calculated by this modelling is $1/\alpha = 4$ MPa, which is in the same range than the values derived from the isotherm. The good agreement of the model and the experiment emphasize the validity of the two-phase flow model for gas pressures below the minimal principal stress.

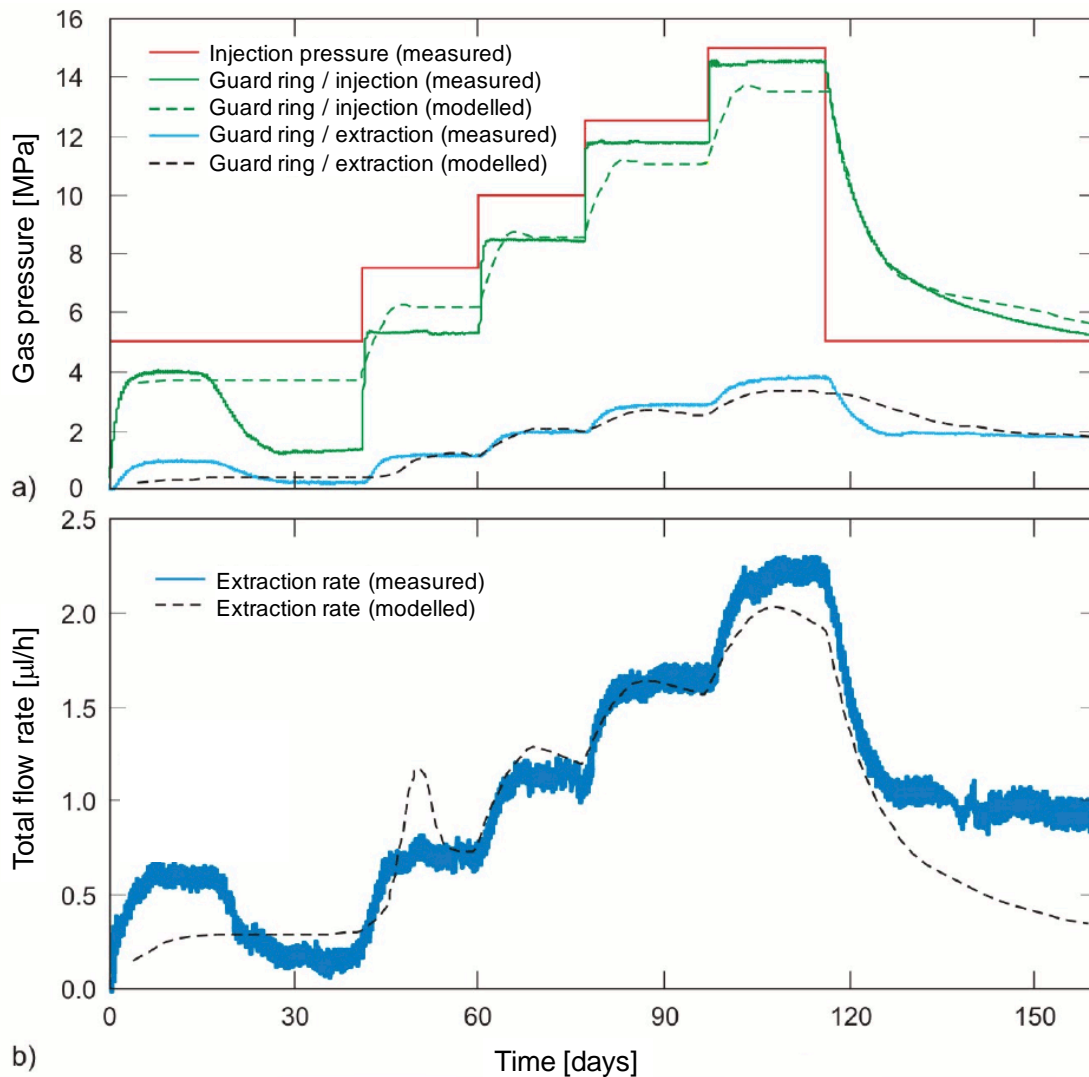

Fig. 19 Gas permeability measurements (solid lines) and modelling (dotted lines) for the Opalinus Clay at the Benken site /NAG 02a/. Pressures measured are the fluid injection pressure and injection/extraction pressures at the sample observed on guard rings.

In conclusion it can be stated that two-phase flow is the most likely gas-transport mechanism if the gas pressure is below the minimal principal normal stress. The gas transport can sufficiently well be modelled with well-established two-phase flow models. However, it is questionable whether the gas transport by two-phase flow is sufficient to dissipate the gas produced in the repository (see discussion in the section "Transport capacity" below). In this case the gas pressure might rise above the minimal stress leading to additional gas transport mechanisms.

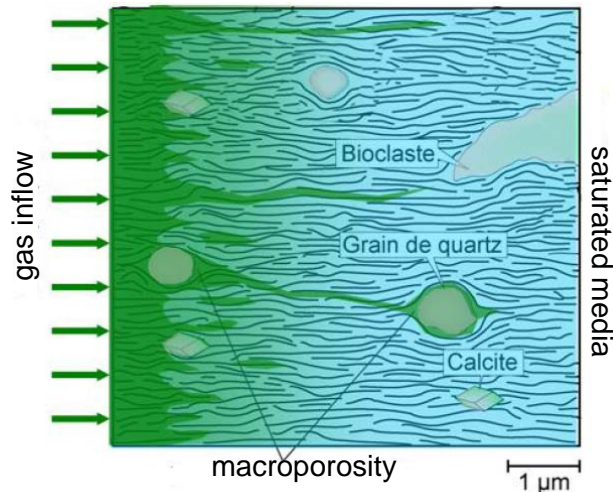

Fig. 20 Pathway creation by pore space widening

If the gas pressure in the waste repository exceeds the minimal principal stress, it is not expected that clay formations can withstand the pressure over long time scales because they usually have a rather low tensile strength. Therefore, if the gas pressure exceeds the principal stress, microfractures are formed in the clay formation. The tensile strength has a high heterogeneity on a micro scale. If the gas pressure locally overcomes the contact forces, the porosity is locally enlarged at the weakest point by compressing the clay matrix; the gas can migrate towards the larger porosity and the microfracture propagates. These microfractures do not only increase the pore space but also the gas permeability of the formation leading to a notable increase in the gas transport. This effect – so called "pathway dilation" – has been described e.g. by /HOR 96/. The penetration of the gas into the newly created pore space is causing only minor desaturation and the gas pathways are believed to be resealed as soon as the gas flow decreases and water resaturates the pore space /SWI 01/.

Since the porosity of the clay is changed by the pathway dilation and the porosity therefore becomes a function of gas pressure, the classical models for the two-phase flow like van Genuchten are - strictly speaking - not valid for the description of the dilatancy controlled gas flow. Additionally, the gas transport does not necessarily involve transport of pore water. Currently no models exist to describe the dilatancy controlled gas transport. Nevertheless, two different phenomenological types of approaches are currently used to describe the dilatancy controlled gas transport in safety assessments. The first one are the two-phase flow models with adjusted parameters and the second one is the modified Darcy's law for compressible media,

which is usually also used to analyse gas permeability experiments: the gas flow \mathbf{q} is proportional to the intrinsic permeability k_g and the gradient of the square of the pressure p :

$$\mathbf{q} = A \frac{k_g}{2\eta p_r} \nabla p^2 \quad (4.9)$$

in which denotes:

- A cross section,
- η dynamic viscosity and
- p_r reference pressure

This approach has been used by NAGRA for the safety assessment of Benken site /NAG 02b/, /NAG 04/. The advantage using this equation is directly related to the results obtained from experiments, i.e. reproduces the gas flow as obtained in the experiment.

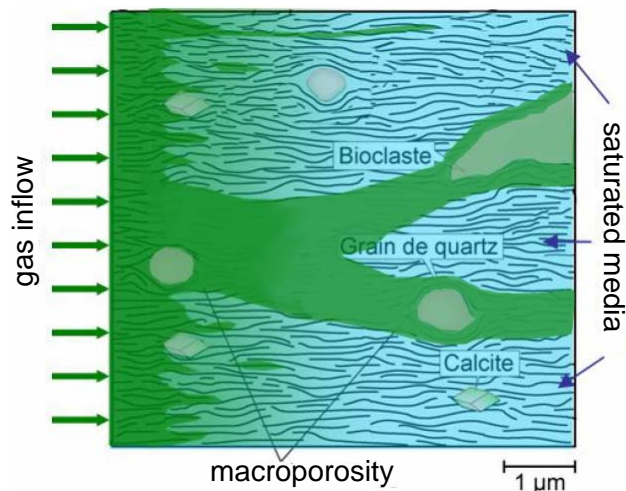

Fig. 21 Pathway creation by fracturing

As noted before, an additional transport mechanism could occur in clay formations if stress on the rock matrix is exceeding the clay rupture strength; namely the creation of fractures, which includes the disturbance of the clay matrix. Models for fracturing caused by fluid injection – so called hydraulic fracturing – have been developed for the exploitation of petroleum and gas repositories. Models for the hydraulic properties of

fractures exist for hard rock, but the "applicability to fractured argillite may be limited" /NAG 04/. The pressures applied for fracturing in the petroleum and gas industries are by far higher than those developing in waste repositories.

Borehole tests and scoping calculations have shown that fracturing only occurs if either the gas generation rate is by orders of magnitude higher than it is expected in a waste repository (see in section "Transport capacity" below) or the change in the gas pressure is very quick. As both situations are not expected in waste repositories, the occurrence of macroscopic gas fractures is usually neglected.

Different experimental work is currently prepared to study the effect of dilatancy controlled gas transport in consolidated clays using either drill cores in the laboratory experiments or in-situ experiments in the underground laboratories at Mont Terri and Bure. Some of the experiments and their results are shortly summarised in the following.

Selected gas transport experiments

Fig. 22 shows the pressure evolution and the derived gas flow measured in a gas threshold pressure test named O5 that was performed in the Benken borehole at a depth of about 600 m /MAR 05/. The test-interval was pressurised in several steps at different gas inflow rates from about 6 MPa to 11.3 MPa and the response of the system was recorded. In a first step the pressure was increased up to about 11 MPa and the test interval was shut in for about five hours. Within this time no notable pressure release and therefore no transport of gases into the formation was recorded. In a second step the pressure was increased once more over a time of about three hours to a final pressure of 11.3 MPa. During this second shut-in phase the pressure remained nearly constant indicating no or only small dissipation of gas into the formation. After a few hours the pressure decrease more rapidly indicating higher gas flow and suggesting that the clay formation was able to withstand the high gas pressure for some time, but then weakens and begins to leak. This temporal behaviour is rather untypical for two phase flow and is therefore regarded as evidence for the occurrence of pathway dilation. The measured gas flow corresponds to a specific gas flux through the borehole wall in the order of magnitude of $1 \cdot 10^{-5} \text{m}^3_{\text{STP}} \cdot \text{m}^{-2} \cdot \text{s}^{-1}$.

Fig. 23 show the results from gas injection tests on Opalinus Clay samples that has been performed by IfG Leipzig /POP 07/. In the laboratory experiment an Opalinus Clay sample was confined at a pressure of 3 MPa and was flown through by gas perpendicular to the bedding. The gas pressure, gas flow and sample permeability were recorded during the experiment (Fig. 24). The gas pressure was stepwise increased to 2.5 Mpa, where it was kept for more than 30 minutes resulting in a constant gas flow. Further stepwise increase of the gas pressure to a value very close to and even slightly above the confining pressure led to slight increase in the gas flow through the sample according to the pressure increase but not in an increase of the sample permeability. This behaviour can be explained by two-phase flow.

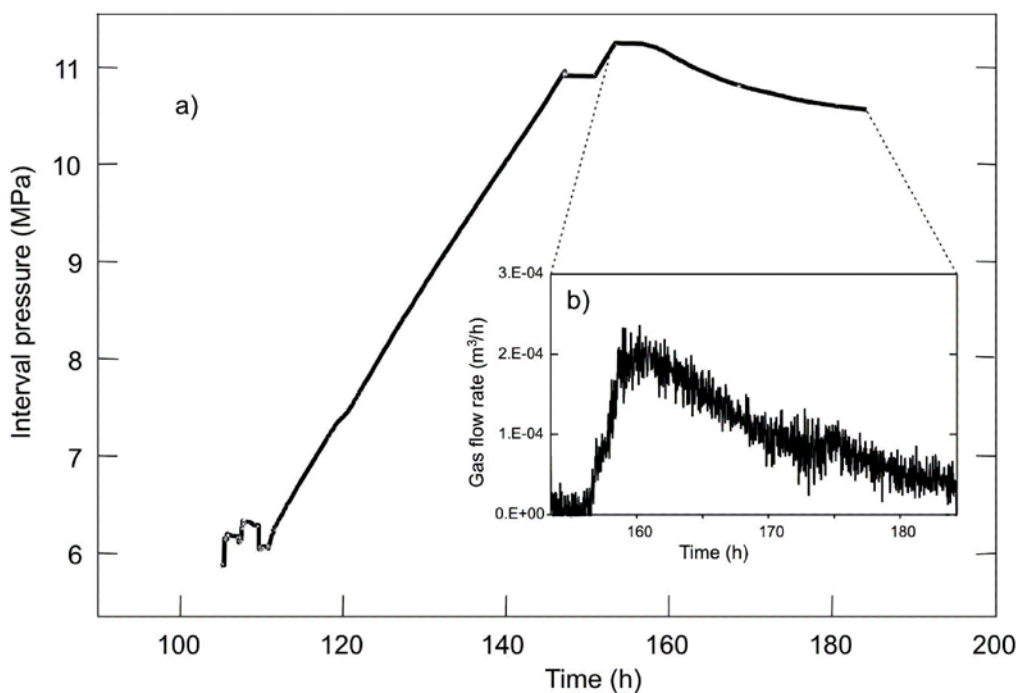

Fig. 22 Pressure evolution (a) and gas flow rate (b) from the gas threshold test O5 performed in the Benken borehole /MAR 05/

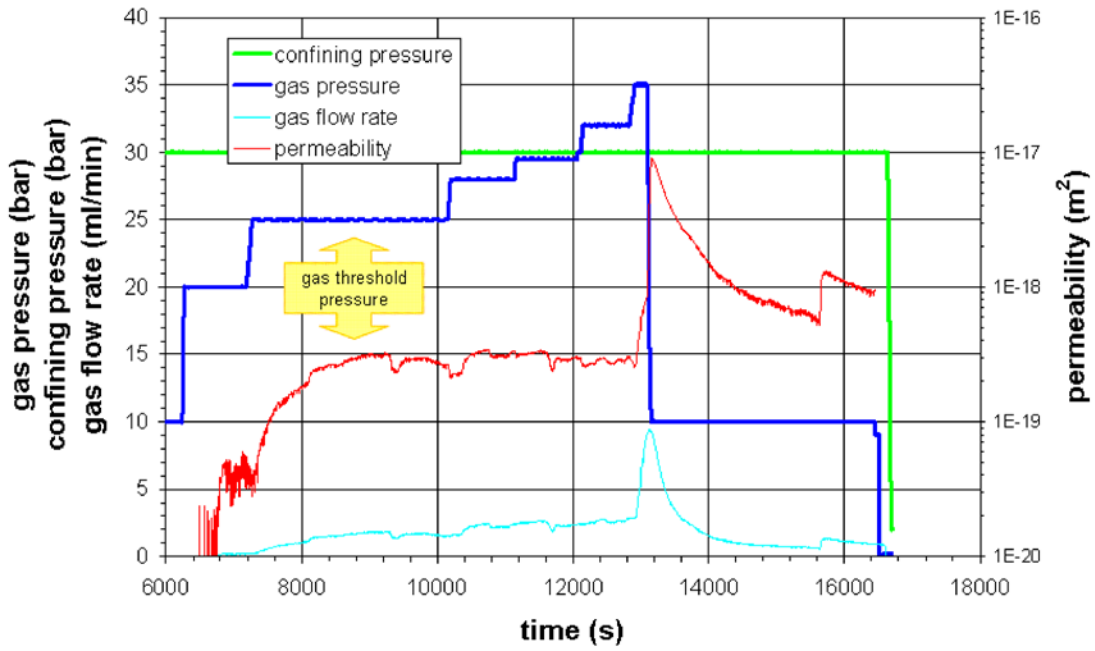

Fig. 23 Gas injection test on an Opalinus Clay core sample /POP 07/.

A further increase of the gas pressure above the confining pressure up to 3.5 MPa led to an abrupt increase of the permeability that involved also a sharp increase in the gas flow rate. This increase in the gas permeability cannot be explained by two-phase flow but only by pathway dilation. After the gas pressure was lowered below the confining pressure the permeability slowly recovered to values near the initial state. This is an indication for the reversibility of the pathway dilation process.

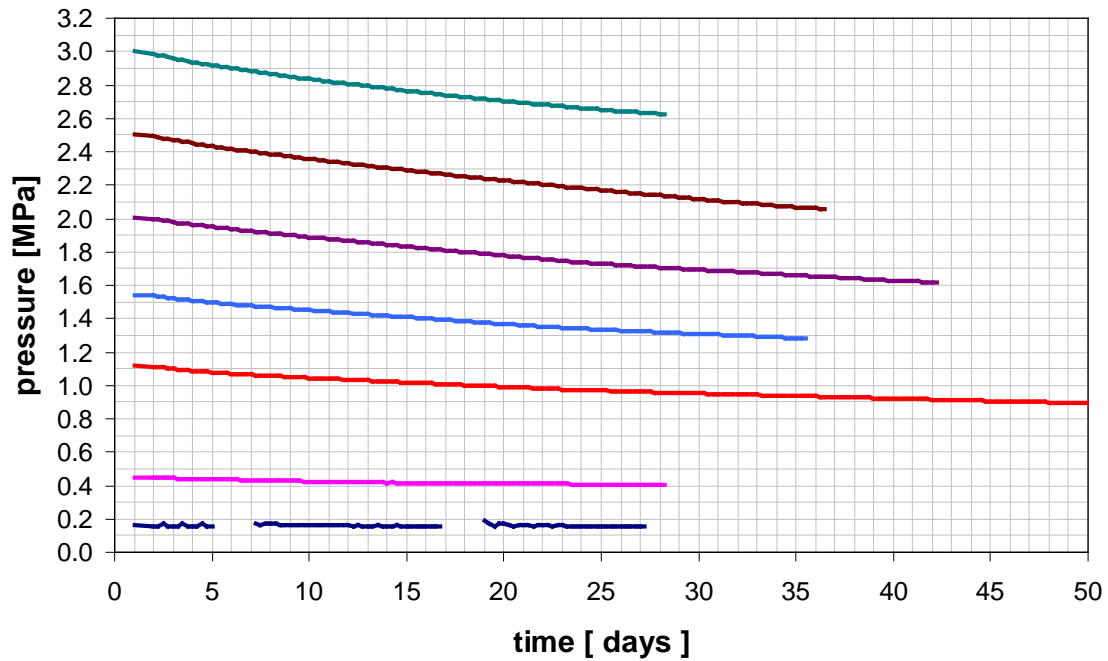

Fig. 24 Pressure trends for different pressure steps in the injection interval of one of the boreholes of the HG-C Experiment /JOC 08a/

A series of gas migration experiments has been recently started in the Mont Terri underground laboratory, named as HG. While the HG-A experiment by ANDRA, BGR and NAGRA aims at demonstrating gas transport in the backfill and the host rock in scale of the actual emplacement tunnel, the experiments HG-B by ANDRA and BGR and HG-C by GRS and NAGRA are more "conventional" borehole experiments that aim at process level studies of gas transport in the formation with special focus to the dilatancy controlled gas flow. These experiments are either in construction or in an early experimental phase; no final results can be given. First results were reported for the HG-C experiment /JOC 08a/. This experiment consists of several multi-packer boreholes; the gas flow is determined parallel and perpendicular to the bedding between the different testing intervals. Fig. 25 show the temporal evolution of the gas pressure in the injection interval after being stepwise pressurised from 0.2 to 3 MPa. The ensuing pressure decay is due to gas transport into the matrix by diffusion and advection corresponding to a matrix permeability of 10^{-19} m^2 . Sudden gas flow was observed for the borehole perpendicular to the bedding if increasing the pressure to 3.0 MPa. Whether it is two-phase flow or dilatancy controlled gas flow has to be evaluated.

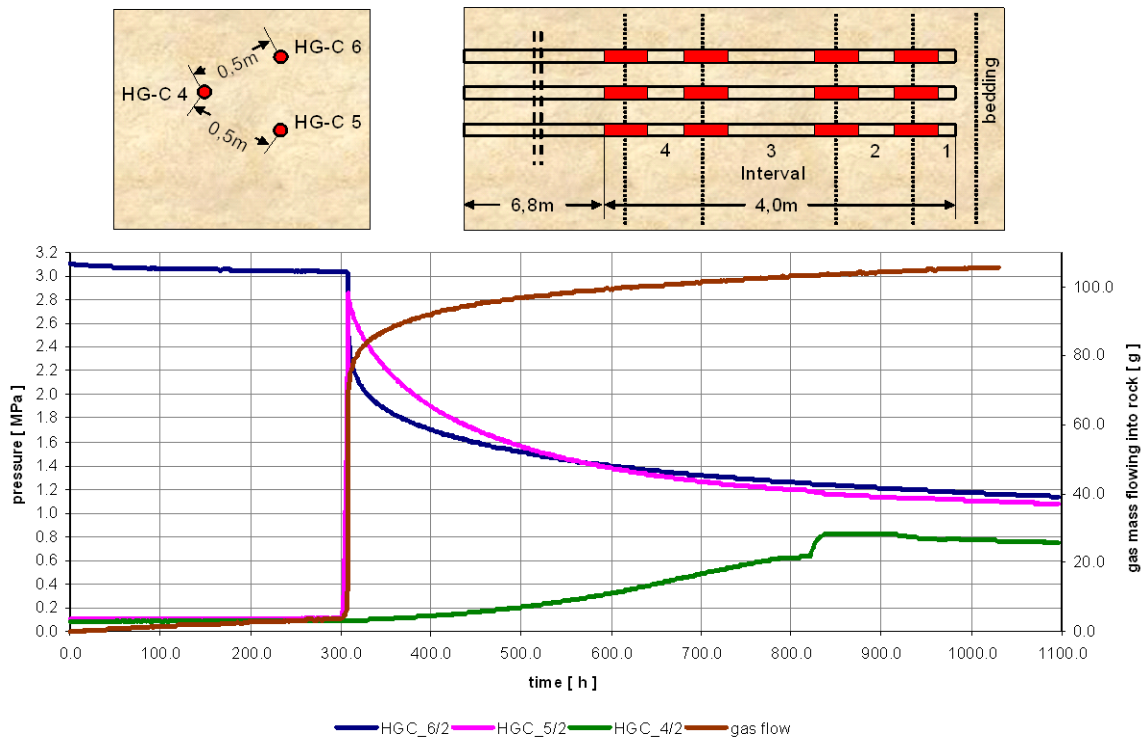

Fig. 25 Borehole layout (upper figure) and gas inflation and gas break through in the interval perpendicular to bedding in the HG-C Experiment /JOC 08c/

Gas transport capacity

The proportionate contribution of the three different gas transport processes described above to the overall gas transport of Hydrogen out of the repository was estimated by scoping calculations for conditions typically for the Benken site /NAG 04/. The results are shown in terms of the gas transport capacity, given as the volume of gas that potentially can be dissipated per year through 1 m² of the emplacement tunnel wall versus the gas pressure (Fig. 26). Multiple calculations were performed for fixed gas pressure between 7 and 15 MPa in the emplacement tunnel. Intrinsic permeability of 10⁻²⁰ m², apparent gas-entry pressure of 5 MPa and in-situ pore-water pressure of 6.5 MPa were assumed.

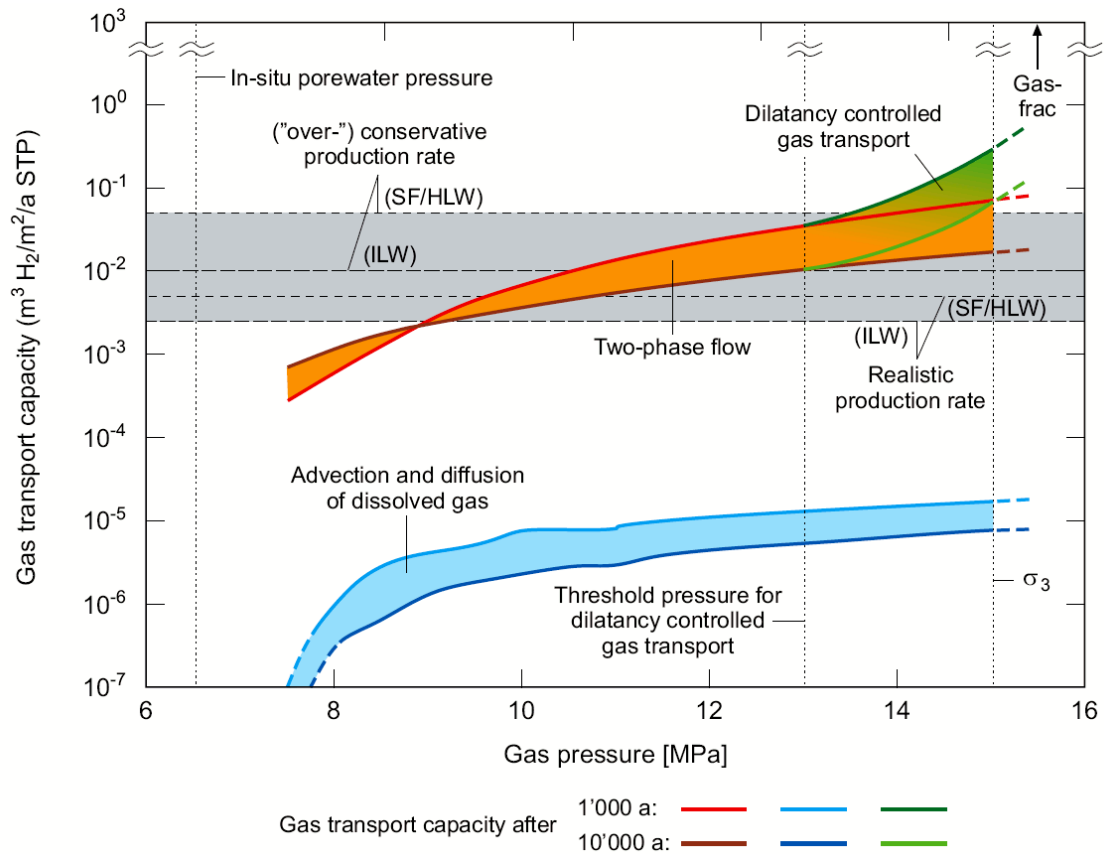

Fig. 26 Transport capacity of the three gas transport mechanisms determined from scope calculations /NAG 04/

The two-phase flow principally starts if the gas pressure exceeds the sum of the pore water pressure and the gas entry pressure, i.e. about 11.5 MPa, but according to the van Genuchten model small gas transport already occurs at lower pressures. For this calculation it was assumed that dilatancy controlled gas flow starts if a pressure of 13 MPa is exceeded (2 MPa below the principal stress of 15 MPa) and that the permeability linearly increases between 13 and 15 MPa by one order of magnitude.

It can be seen that the gas transport capacity of all three processes is not stationary but show a distinct dependence of both time and gas pressure. While the gas pressure dependence is inherent to the gas transport models applied, the time dependence is mainly due to changes of transport parameters in the host rock due to the propagation of the gas front, like the change of the saturation state.

The grey shaded area gives the expected range of the gas production rates for the conditions of the repository in Benken considered by NAGRA. That focus on the gas production from the spent fuel emplacement areas with a gas production rate of

0.04 m³_{STP} per year and meter of tunnel length for the realistic case and one order of magnitude higher for the conservative case. The gas transport by diffusion and advection of gas which are dissolved by the pore water leads to gas transport rates at least two orders of magnitude below the expected realistic gas generation rate. Therefore, it is ineffectively contribute to the overall gas transport.

The classical two-phase flow according to van Genuchten model is able to transport amounts of gases which are in the same order of magnitude as the realistic gas production rates, at gas pressures which are still below the gas pressure needed to create dilatancy controlled gas flow. If the gas production rate will be higher than assumed for the conservative case, two-phase flow is not sufficient to dissipate the generated gas and the gas threshold pressure for dilatancy controlled gas flow is exceeded. The actual gas transport rates for the dilatancy controlled gas transport have to be regarded with caution due to the imponderableness in the model as noted above.

However, the dilatancy controlled gas transport is believed to be sufficient to dissipate the gas from the repository without creating any irreversible changes to the rock matrix. The formation of macroscopic fracs is expected not before the gas pressure exceeds 17.5 Mpa but the gas transport capacity at 15 MPa gas pressure already exceeds the gas production rate even for a pessimistic gas generation rate (Fig. 26). Therefore, further gas pressure increase and formation of gas fracs have not to be expected.

The corrosion rate and thus the gas generation rate expected for the conditions in a repository in the German Lower Cretaceous Clays will be within the range of the gas generation rates assumed in the scoping calculations by NAGRA. Therefore, similar conclusions could be drawn for a repository in the Lower Cretaceous Clays in Germany. This has to be proven by simulations regarding site-specific gas transport parameters, site-specific stress and the repository layout.

4.1.1.3 Gas transport in the engineered barrier system

Besides the gas transport in the clay formation itself, the gas transport in the backfill of the emplacement tunnels and in the seals plays an important role for the gas pressure evolution in the repository. In the most of repository concepts in clay bentonite or bentonite sand mixtures in crushed, pellet or compacted form is foreseen for the backfilling and the seals. These materials are also considered as buffer material in

waste repositories in hard rock formation, e.g. /SKB 06/. The gas transport and the validity of the two phase flow model for the gas transport in bentonite buffers has been shown in various experiments and modelling exercises, e.g. /SWI 01/.

In the recent years it has been addressed by several projects, whether a targeted choice of the buffer material could lead to positive characteristics of the engineered barrier system with regard to the gas transport properties /MIE 03/. Especially clay/sand mixtures show high gas permeability at the dry state and still low gas entry pressures at the saturated state. Thus, gas overpressures could be easily dissipated through the engineered barrier system if the intrinsic permeability is low enough to effectively prevent advective water flow. These questions have been addressed for variable sand/clay fractions of the buffer material in laboratory experiments and in the SB in-situ experiment /ROT 05/ which are currently performed at Mont Terri as part of the project ESDRED.

The laboratory experiments performed as pre-project for the SB experiment have shown that the gas entry pressure is lower for higher fractions of sand in the mixture. Fig. 27 illustrates the gas pressure and the gas flow rate versus time for different mixtures. The gas entry pressure is rising with increasing clay fraction and also the time needed for gas breakthrough. The gas pressure at the inlet is rising until it is exceeding the gas entry pressure. Subsequently the gas pressure is decreasing rapidly and the gas is breaking through at the outlet. The time until the break-through occurs is remarkable different for both mixtures, being a sign for the difference in the two-phase flow transport parameters. After some time more or less a steady state between inlet and outlet flow is reached.

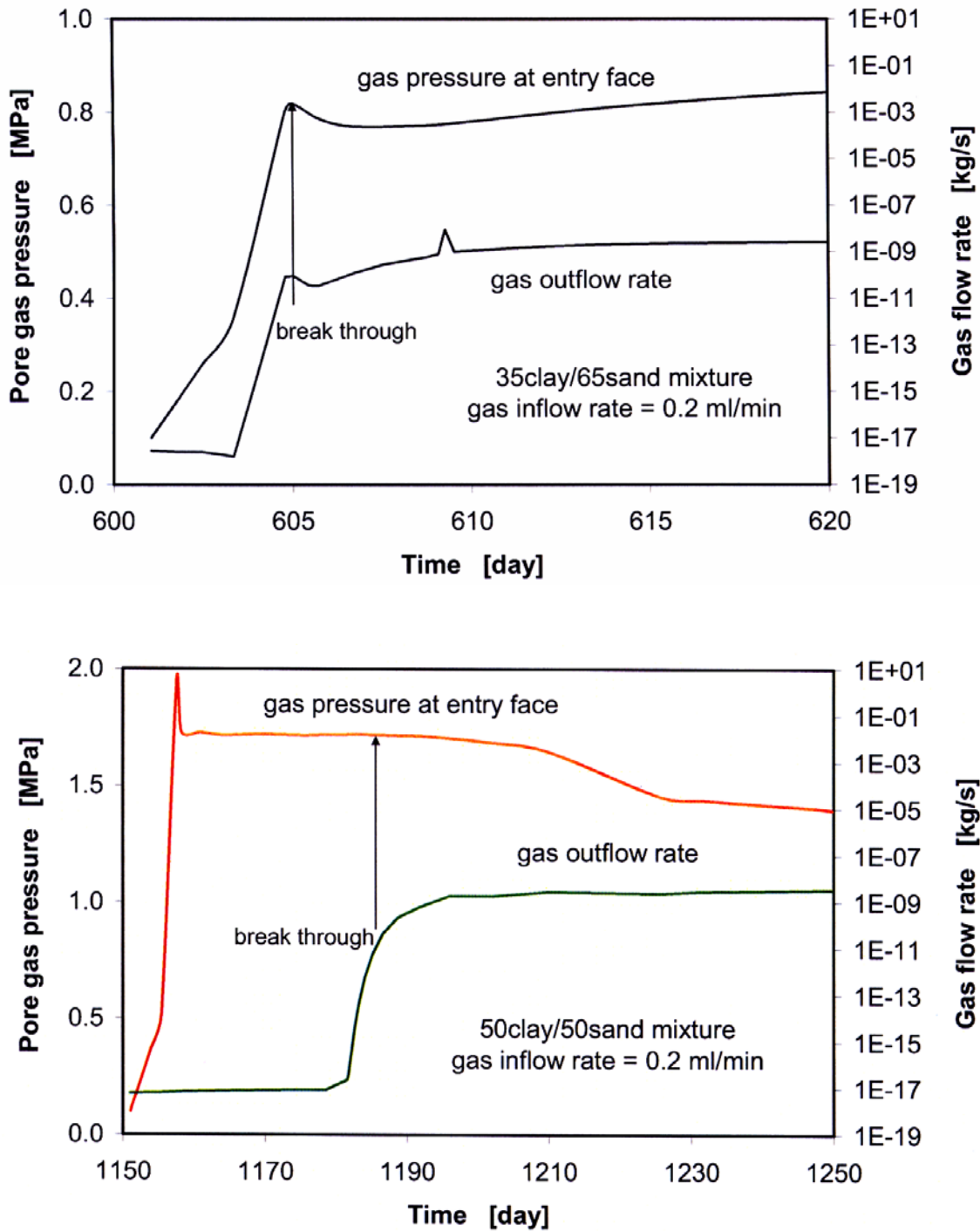

Fig. 27 Evolution of the gas pressure at the gas entry face and gas outflow rate for clay/sand mixtures of 35/50 (above) 50/50 (below) /ROT 05/

On the one hand, the gas transport through the engineered barrier system might be used to make the whole waste repository system more robust. Using bentonite/sand mixtures as backfill the gas transport through the engineered barrier could lead to an effective dissipation of the gas and also to low values of the gas pressure in the emplacement tunnel with the advantage that the two-phase flow might be sufficient as

gas transport in the host rock formation. On the other hand, it is most likely that the gas transport even by dilatancy controlled flow does not affect the barrier integrity of the clay host rock formation. Therefore, it might be favourable to use pure bentonite as backfill to restore the conditions in the repository mine as close as possible to its original state.

The consideration of bentonite/sand mixtures versus pure bentonite as backfill on the gas transport in the engineered barrier system and on the whole system performance have to be assessed specific for a host rock type and repository concept both by thermo-mechanical calculations and gas or radionuclide transport calculations for the whole repository system. For a repository in Germany those assessments currently cannot be performed due to lack of an advanced repository concept and host rock specific data.

4.1.1.4 Conclusions

Currently, the gas transport in clay formations is intensively examined in laboratory and field experiments. Although a lot of information is already gained, a complete picture of the gas transport in argillaceous media is not yet achieved. Due to the substantial progress expected in the near future the conclusions given here might be outdated within short time.

Different gas transport mechanisms exist in clay formations depending on the gas pressure in the waste repository:

- **Diffusion and advection of gases** dissolved in the pore water always occurs if gases are present, even at low gas pressure. The processes are well understood and established phenomenological models exist with Fick's and Darcy's laws to model the gas transport of dissolved gases. Data from other formations could be used to model these processes sufficiently well for a repository in a clay formation in Germany. However, these processes only insignificantly contribute to the overall gas transport from a repository.
- **Two-phase flow** of gas and water in the pore space occurs if the gas pressure in the waste repository exceeds the gas entry pressure. The gas-entry pressure is specific for a rock formation. Different parameter models exist to model the two phase flow in porous media; the most common one is the Mualem-van Genuchten

model. The successful modelling of gas permeability tests on Opalinus Clay samples has given confidence, that the model can be applied to two-phase flow in consolidated clays. Curves for the dependence of the capillary pressure versus the water saturation needed as input parameter of the Mualem-van Genuchten model have been derived for the Opalinus Clay and the Callovo-Oxfordian Clay.

To model the two-phase flow for a German repository in consolidated clay, the gas permeability, gas entry pressure and the dependence of the capillary pressure from the water saturation will have to be determined in experiments.

- **Dilatancy controlled gas flow** occurs if the gas pressure exceeds the minimal principal normal stress of the formation. In this case a widening of the pore space takes place at microscale. These microfractures highly increase gas permeability without disturbing the rock matrix structure. This process has been assumed for plastic clays and laboratory experiments as well as in-situ gas permeation experiments have given indications that this process also exists for consolidated clays. Some experiments are currently performed to study this process and more evidence for the existence of this mechanism in indurated clay is expected.

Principle geomechanical considerations exist to explain this process. However, neither a mechanistic understanding nor an adequate phenomenological model currently exists to model the dilatancy controlled gas flow. For the clay formation regarded as potential host rock for a repository in Germany as first step, the occurrence of dilatancy controlled gas flow for this formation will have to be demonstrated in laboratory and in-situ experiments.

- **Macroscopic fracturing** occurs if the gas pressure exceeds the breakdown threshold of the clay formation. Either very high gas pressure or fast change of the gas pressure is prerequisite to create macroscopic fractures. Because of low gas production rates, neither nor is expected in a repository for radioactive waste. Therefore, this process will be usually excluded in a safety case. However, this has to be proven for every repository concept with the main impact of the inventory, repository layout and formation parameters.

Besides the host rock formation the engineered barrier system might notably contribute to the dissipation of the gas from the repository mine. Special clay/sand mixtures are in discussion as barrier material characterized by low permeability for liquid and also low gas entry pressure. Therefore, might rather lead to a preferential gas flow through the

engineered barrier system. However, if the gas transport by dilatancy controlled flow does not affect the barrier integrity of the clay host rock formation, it might be favourable bentonite as backfill to restore the conditions in the repository mine as close as possible.

For safety assessment a detailed calculation is necessary to estimate the contributions of different gas transport pathways to the overall gas transport and the gas pressures in the repository mine. However, models for these calculations currently exist for diffusion and advection and for the two-phase flow. For the dilatancy controlled flow one currently falls back on the models for two phase flow or Darcy flow which both are strictly speaking not valid. In the best case one will not have stress dilatancy controlled flow if two phase flow through the formation and the engineered barriers together suffice to dissipate the gases from the repository.

In Germany tools for the calculation of the gas transport from a repository in clay formations do not exist. However, there is not a high pressure to develop such tools since no programme for high level waste repository in clay formations currently exist. Therefore, it seems more effective to further follow the results of the gas migration experiments from the Swiss and French waste repository programmes and develop national simulation codes for the dilatancy controlled gas flow in clay formations if there is a need by the national programme.

4.1.2 Excavation disturbed zone

4.1.2.1 Definitions

The Cluster Conference of the EC in 2003 was exclusively devoted to the topic “EDZ”. However, in different contributions EDZ was explained as “Excavation Damaged Zone” or “Excavation Disturbed Zone”. The meaning of each explanation was differently interpreted by several authors. In order to unify the usage of these expressions the following definitions for the adjectives “damaged” and “disturbed” were suggested with respect to long term safety of a repository /BEP 03/:

- Excavation Disturbed Zone (EdZ): The zone in the host rock where all changes caused by excavation are reversible.

- Excavation Damaged Zone (EDZ): Changes due to excavation are not reversible and can form preferential pathways for radionuclides in the host rock.

Alternatively, it was suggested to define “EDZ” as that zone in which changes of hydromechanical and/or geomechanical properties of the host rock cause significant changes of the flow and transport properties. This definition has been adopted by ANDRA /AND 05a/ in the meantime. In the present report “EDZ” is used according to the definition given in /BEP 03/.

Furthermore, the difference between “healing” and “sealing” was clearly defined /MCE 03/, /BEF 06/:

- Sealing: discontinuities created during excavation close again in such a way that forces due to increased stresses in the rock, changes of water content and/or swelling of clay minerals can be transferred across these discontinuities. If no structural changes occur at the boundaries of the discontinuities no bonding results from sealing. Mechanical reloading can therefore open these discontinuities again.
- Healing: healing is defined to have occurred if the hydraulic and mechanic properties of the undisturbed rock are regained in the formerly disturbed zone to such an extent that the disturbing event has no influence on further evolution. A healed fracture under a recurring mechanical load therefore forms no preferential location for a new fracture. Structural changes at the boundaries of the discontinuities lead to an increase of mechanical stiffness of the rock.

4.1.2.2 Creating of an EDZ

General remarks

The creation of an EDZ is a mechanical process influenced by the local properties of the host rock as well as the way of excavation /BEP 03/, /MAT 03/. Exceeding tensile strength as well as exceeding shear stress in the bedding plane can result in fractures /ALH 03/. These processes create preferential pathways for groundwater and also for mobilised radionuclides if the fractures are connected to more than a certain extent.

For short times the EDZ in claystone behaves similar to an EDZ in granite referring to extension and possibly to the developing structure. In the long term evolution of the

EDZ in these rocks differs due to the more pronounced healing properties of the claystone /MCE 03/. The initial similarity is supported by a phenomenon that has been observed in both formations without being related until now. Measurements of water pressure in the rock at different distances from the drift wall have been performed in the granite of the Hard Rock Laboratory (HRL) Äspö. They show lower permeability in the direct vicinity of the drift wall compared to the permeability at approximately 1 m distance from the wall. Model calculations indicate a difference of about 2 orders of magnitude /LIE 01/. Similar observations have been made for the Opalinus clay. Here, the transmissivity of 10^{-11} m²/s at distance of 20 cm from the drift wall increases up to 10^{-8} m²/s at distance of 60 cm and decreases again beyond that distance /ALH 03/. Both sources do not explain this counterintuitive phenomenon.

The Mont Terri site

The principal values of the anisotropic hydraulic conductivity in undisturbed parts of Opalinus clay amount to $2 \cdot 10^{-14}$ m/s and 110^{-13} m/s /NAG 02a/. These values are typical for the Opalinus clay at Benken site in 600 m depth. Laboratory measurements for the Opalinus clay at Mont Terri in 250 m depth yielded values of 10^{-14} m/s perpendicular to the bedding plane and $2 \cdot 10^{-13}$ m/s in direction of an 45° angle to the bedding plane /ALH 03/. Other investigations provide values of 210^{-14} m/s to 210^{-12} m/s without clear reference to the principal directions /BEF 06/.

The Opalinus clay at Benken has a porosity of about 12 % /BLU 03/, at Mont Terri of about 16 % /NAG 02a/. The pore diameter is less than 25 nm for 75 % up to 90 % of the pore space. Approximately, the half of the void space is filled with bounded pore water. Therefore, only the other half will be available for water flow and transport processes /NAG 02a/. The part of the pore space that is accessible for gas seems to be even much smaller /NAG 02b/.

In the Underground Rock Laboratory (URL) at Mont Terri extension brittle fracturing as well as bedding plane slip can be observed after creation of an EDZ. The first type of failure is found especially at the drift walls while the second type is particularly often seen at the roof and floor of drifts /MAR 03/. That means, an onionskin like fracture system was formed /NAG 02a/.

Investigations after excavation work for the ED-B-experiment at 240 m depth shown the thickness of the created EDZ in the Opalinus clay amounted to about one drift radius /MAR 03/. The referring conceptual model for the EDZ illustrates Fig. 28; it is based on several different tests like ultra sonic measurements, geoelectric measurements and hydraulic tests.

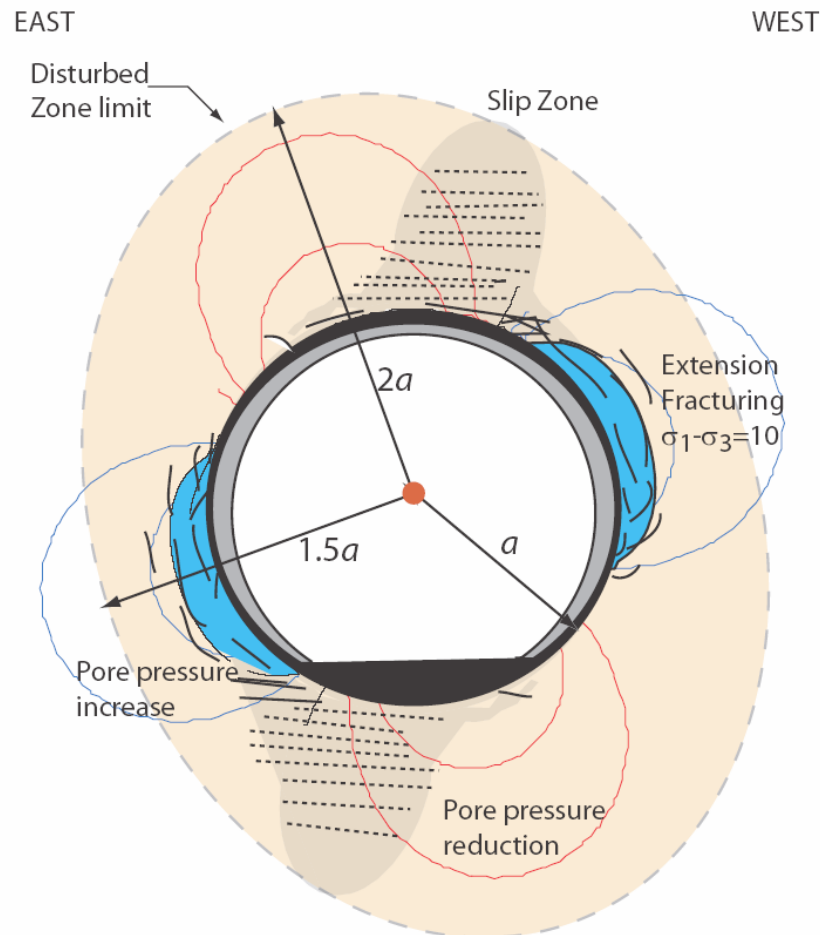

Fig. 28 Conceptual model of the EDZ at Mont Terri; from /MAR 03/.

The most permeable zones after excavation can be found close to the drift walls with a hydraulic conductivity of 10^{-7} to 10^{-8} m/s /MAR 03/, /BLU 05/, according to /NAG 02a/ even of $1 \cdot 10^{-7}$ to $5 \cdot 10^{-7}$ m/s (Fig. 29). In contrast, floor and roof of the drift show only hydraulic conductivities of 10^{-10} m/s /BEF 06/, /NAG 02a/. Differences are considered to be a consequence of different failure mechanisms. Unconnected fracture systems were observed beyond 1 m from the drift wall /MAR 03/. Based on model calculations an increase of porosity of about 2 % at most are expected /NAG 02a/.

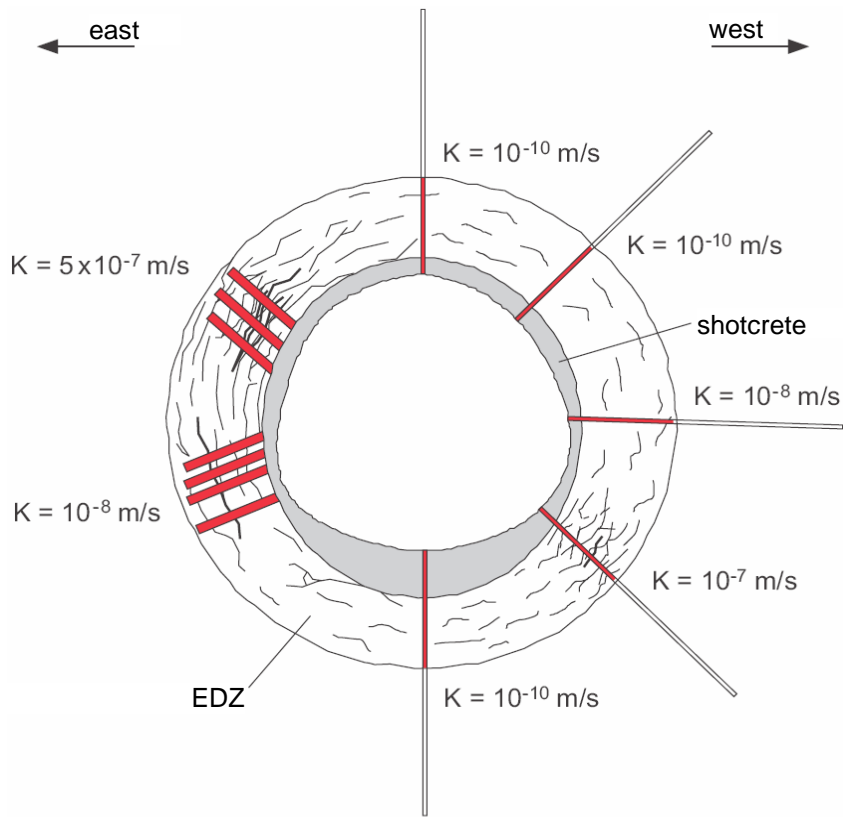

Fig. 29 Hydraulic conductivity of the EDZ, drift in Mont Terri /NAG 02a/.

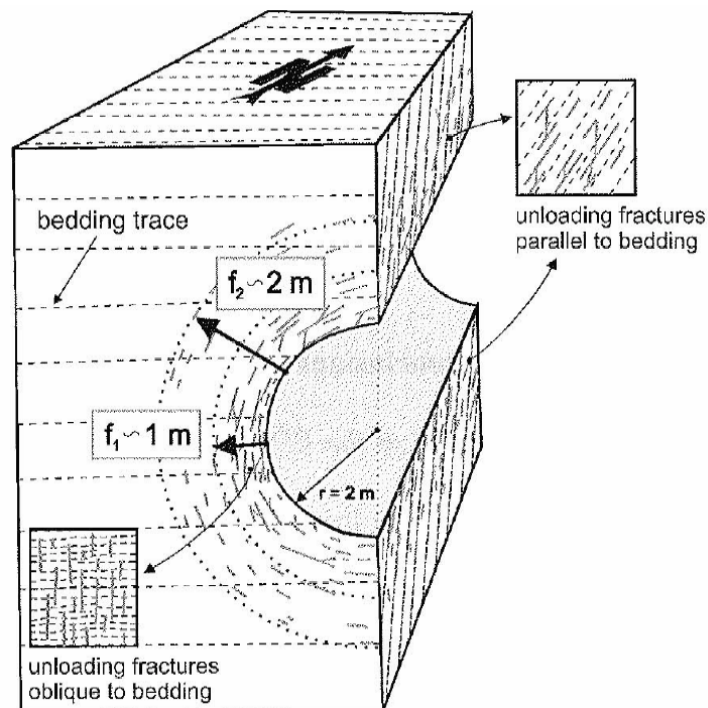

Fig. 30 Alternative conceptual model for the EDZ /BOS 02/.

Another model explaining the fracture systems - also used for the Bure site - is shown in Fig. 30 /BOS 02/. Here, an inner zone with a well connected and air-filled fracture network is distinguished from an outer zone of unconnected fractures that are partly filled with water. Transmissivity of the inner zone lies between 10^{-5} m²/s and 10^{-9} m²/s, the highest transmissivity being found within the first 40 cm from the drift wall. Transmissivity of the outer zones lies between 10^{-9} m²/s and 10^{-12} m²/s. The extension of $f_1=1$ m of the inner zone shown in Fig. 30 is just an average value. The actual extension varies between 0.10 m and 1.25 m /BOS 02/. It is also shown that the fracture density at the drift walls is higher in comparison to the fracture density in the drift floor or the drift roof. However, it could not be clarified whether both conceptual models can be reconciled. Measurements during the ED-A-experiment in Mont Terri provide an indication for the radial distribution of the hydraulic conductivity /NAG 03/. Fig. 31 shows the measured conductivity distribution along six boreholes that were drilled in different directions perpendicular to the drift axis. While the lower four diagrams show the expected exponential decrease with distance from the drift wall, in the upper two diagrams only slight increase can be observed up to 60 cm.

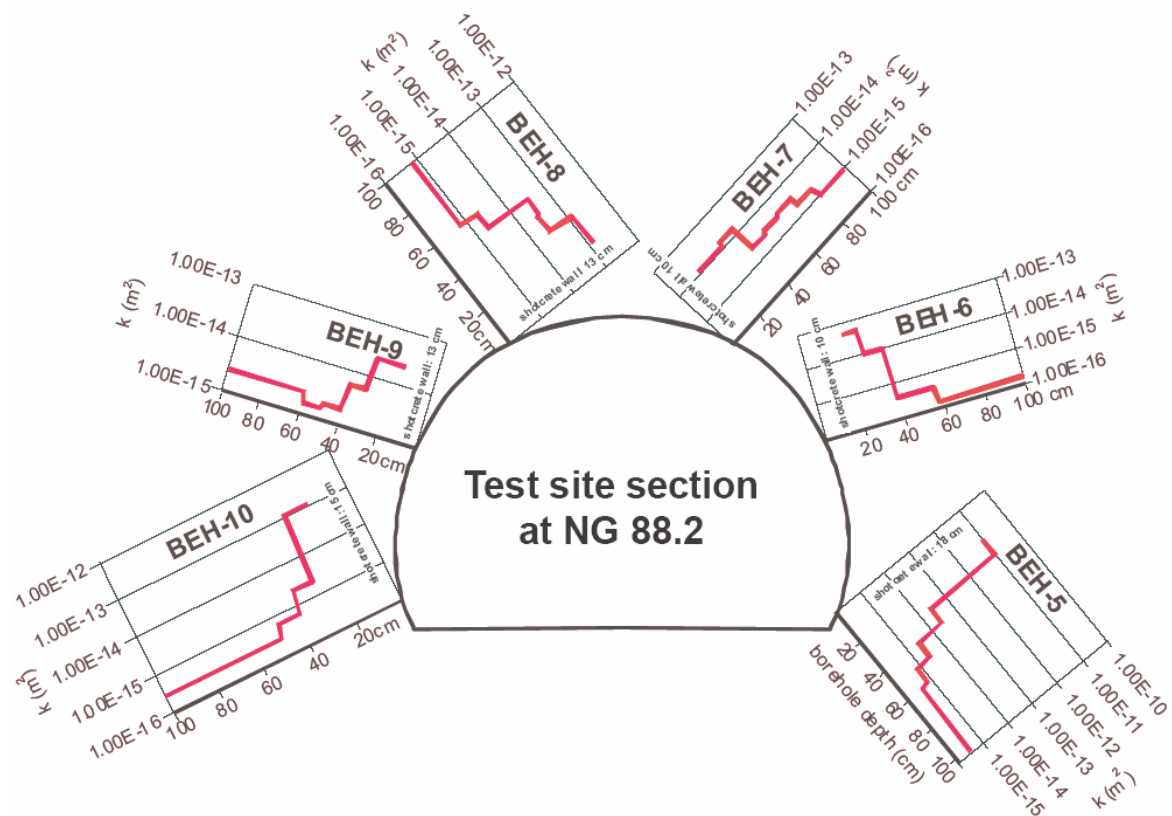

Fig. 31 Hydraulic conductivity of the EDZ, drift ED-A-experiment /NAG 03/.

The Bure site

According to /AND 05a/ the hydraulic conductivity of undisturbed claystone at Bure site lies in the range between $5 \cdot 10^{-14}$ m/s and $5 \cdot 10^{-13}$ m/s. However, a compilation of more than 150 measurements indicates a range of 10^{-14} m/s up to 10^{-12} m/s /CRU 06/. The Fig. 32 shows the increase of the conductivity values with depth which reflects the varying mechanical stability of the claystone with the depth.

Porosity values between 15 % and 18 % have been found but 18 % is assumed as reference value /AND 05a/. According to the frequency distribution about 90 % of the total porosity consists of pores with extremely small diameters (Fig. 33). As a consequence about half of the pore water is bonded to mineral surfaces – indicated in Fig. 34 – where strongly and weakly bonded water is distinguished. For this reason it is convenient to define an effective porosity² which depicts this part of pore space in which flow can actually occur. The effective porosity of the Opalinus clay at Bure site amount to 9 % /AND 05a/.

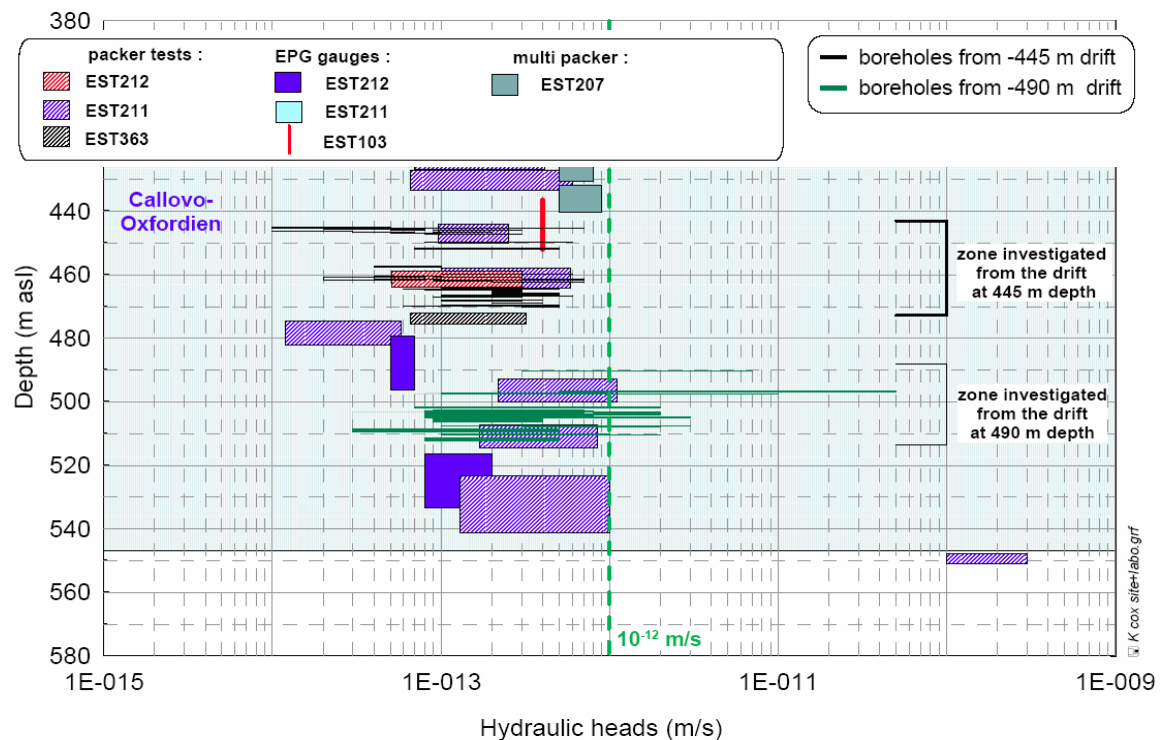

Fig. 32 Measurements of the hydraulic conductivity /CRU 06/.

² In some literature the expression "kinematic porosity" is used synonymously to the expression "effective porosity" as defined here.

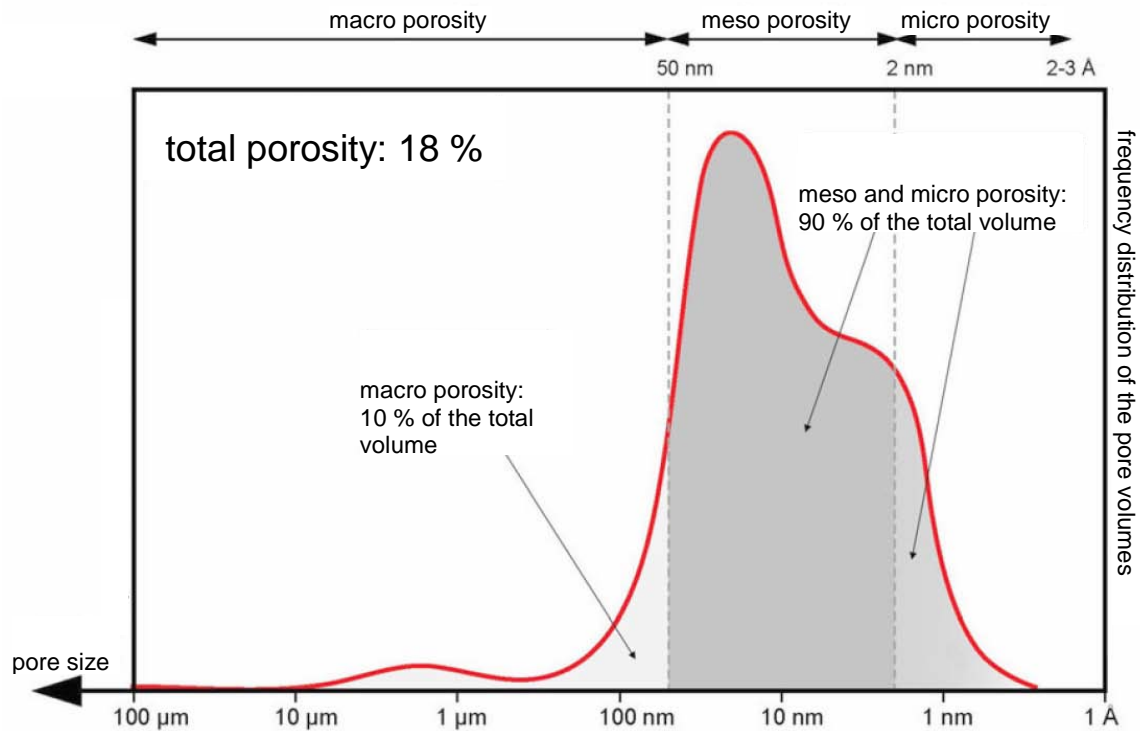

Fig. 33 Frequency of pore diameters /AND 05a/.

The conceptual model for the EDZ at Bure site comprises three components. Stress fractures parallel to the drift wall are located in narrow fringe zones immediately at the drift wall. Next to this zone there is much larger zone of microfissures, also parallel to the wall. Reaching deep into this zone of microfissures system of shear fractures in fishbone-like pattern can also be found, see in Fig. 35 /AND 05a/. Fig. 36 shows this special failure pattern on a core sample. The EDZ only encompass these two zones. Beyond them there is a third zone with excavation induced fractures and strains but the properties of the rock – especially the hydraulic conductivity – are not affected there. With view to hydraulic properties only the inner two zones comprising the EDZ are of interest. They will be called “inner zone” and “outer zone” of the EDZ. Shape and extent of these zones depend on the direction of excavation in relation to the stress field in the host rock. A drift located perpendicular to the direction of the lowest horizontal stress is exposed to more or less isotropic stress field because the lowest horizontal stress is about as high as the vertical stress. In this case circular EDZ forms around the drift cross-section. The highest horizontal stress exceeds the lowest horizontal stress by factor 1.3 which results in an elliptical EDZ, see in Fig. 37.

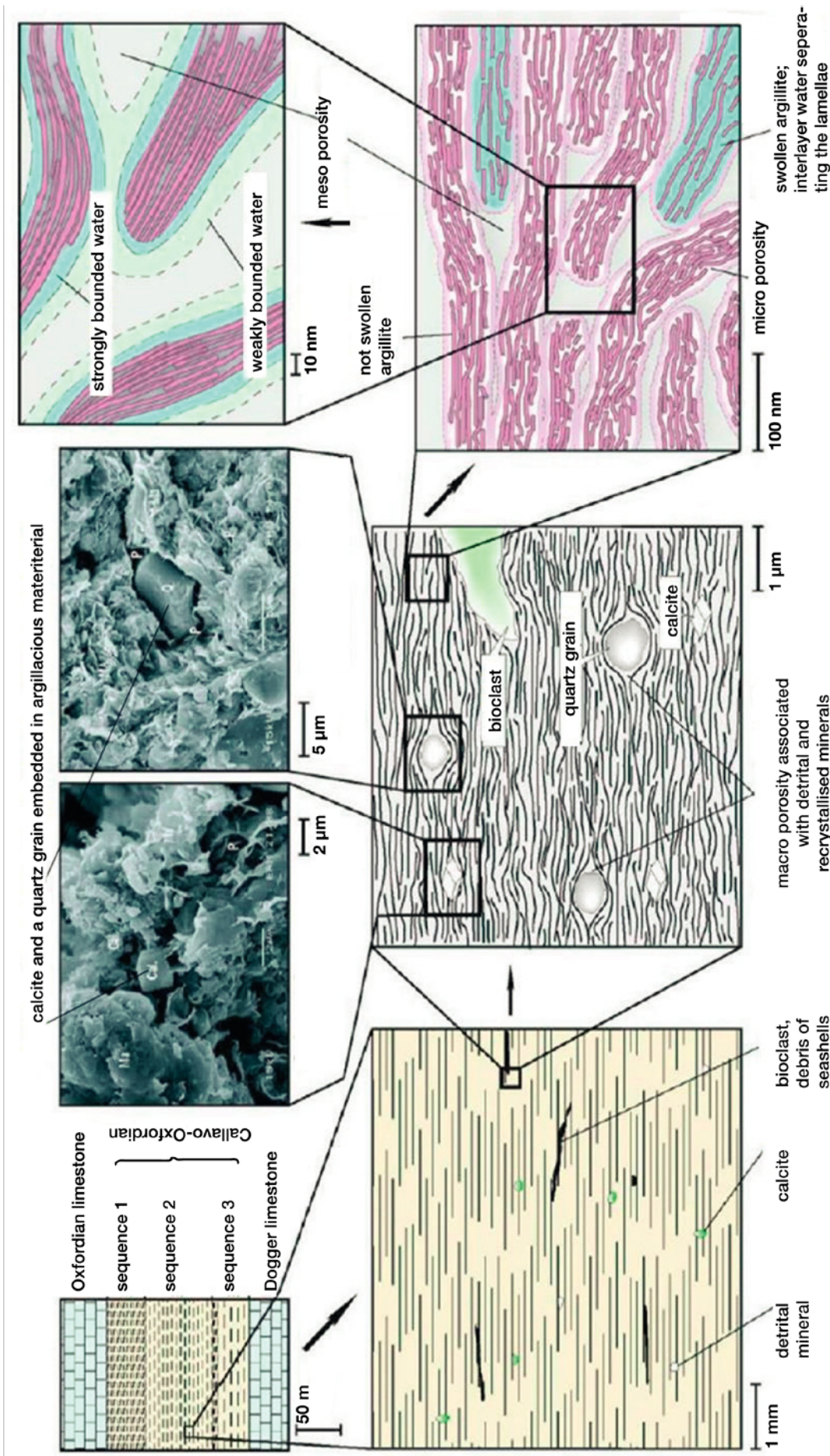

Fig. 34 Texture and structure of the pore space in the Callovo-Oxfordian /AND 05a/.

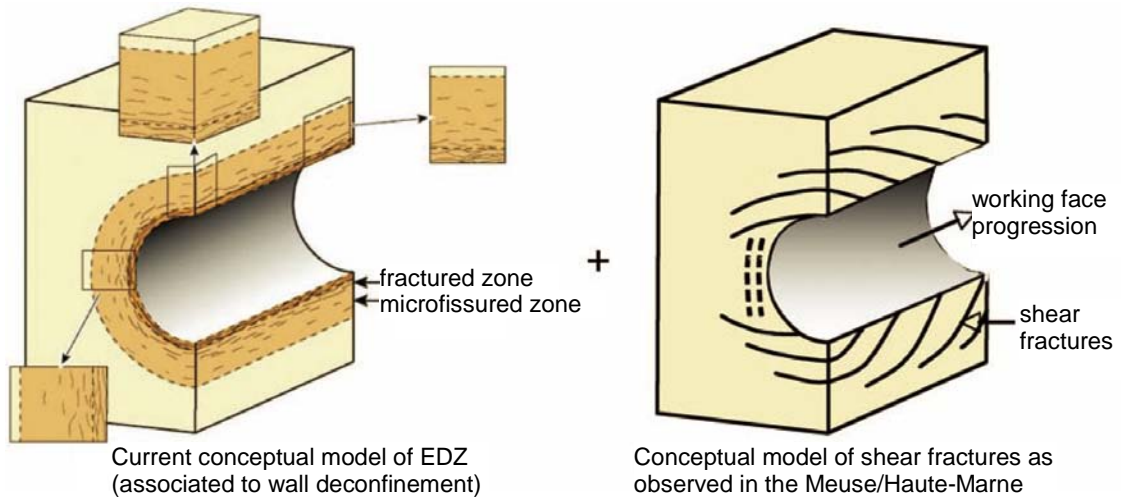

Fig. 35 Conceptual model of the EDZ at the Bure site /AND 05a/.

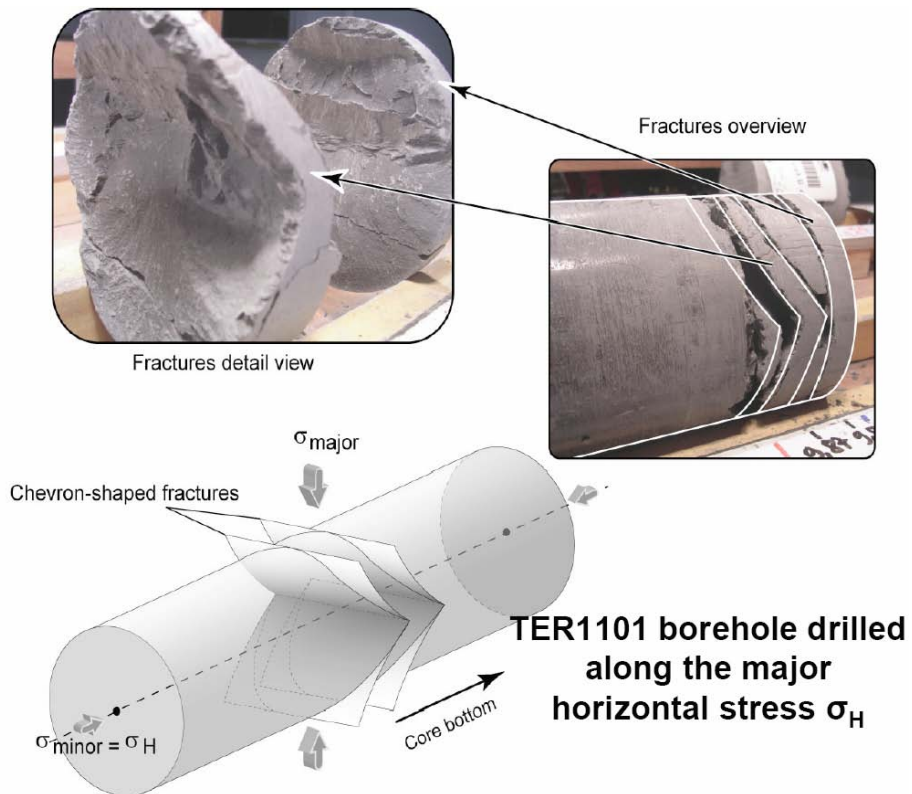

Fig. 36 Fishbone-like failure pattern in a drilling core at bure site /REB 06/.

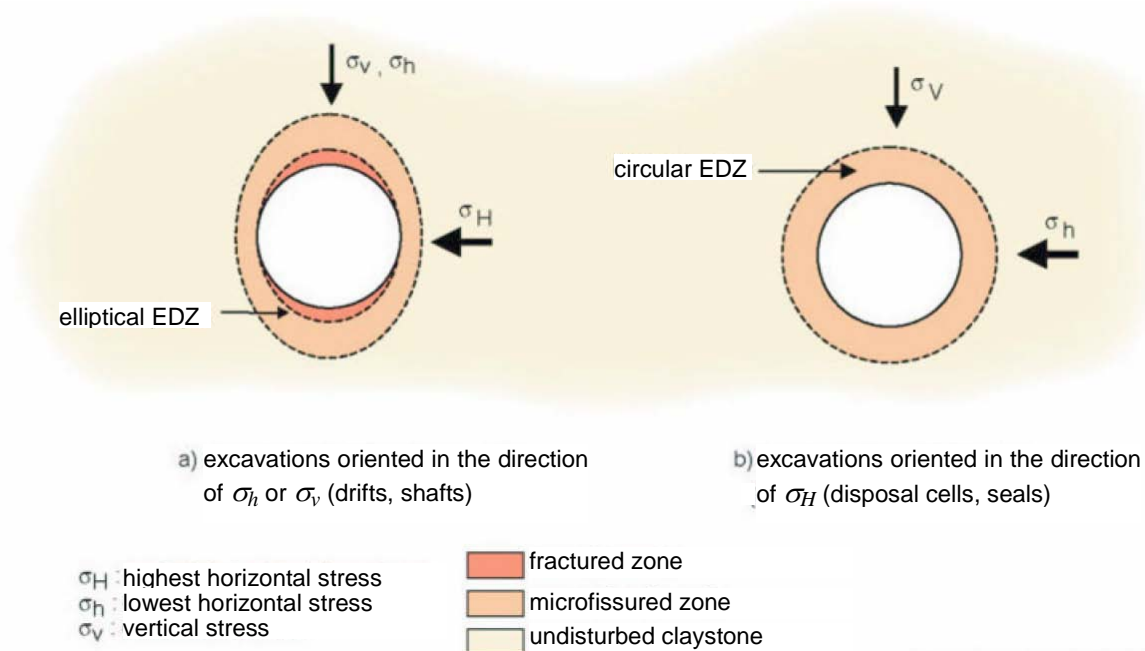

Fig. 37 Shape of the EDZ depending on direction of excavation and stress field /AND 05a/.

The influence of the cross-section of the drift and drift orientation in the stress field on size and shape of the two zones in the EDZ was investigated using two-dimensional numerical models. The third influencing factor is the depth of the drift because three layers of different mechanical properties named zones A to C have been identified in the Callovo-Oxfordian; zone A being the top layer and zone C the bottom layer. The thickness of the inner zone varied between 0 and 0.3 R if R is the initial radius of the drift (

Fig. 38). The width of the outer zone was calculated between 0 and 1.2 R /AND 05a/.

These results were confirmed by measurements in zone C from the SUG-experiment. At drift radius of 2.3 m the thickness of the EDZ was measured between 0.3 and 0.7 m in horizontal direction and about 2.3 m in vertical direction /WIL 06/. The thickness of the EDZ was also measured in-situ shortly after excavation. A new method was used for that purpose allowed spatial resolution of only a few centimetres. The measured thickness of the EDZ amounted to a few decimetres. Based on first observations and measurements as well as model calculations the initial width was estimated to about one drift radius /AND 05a/.

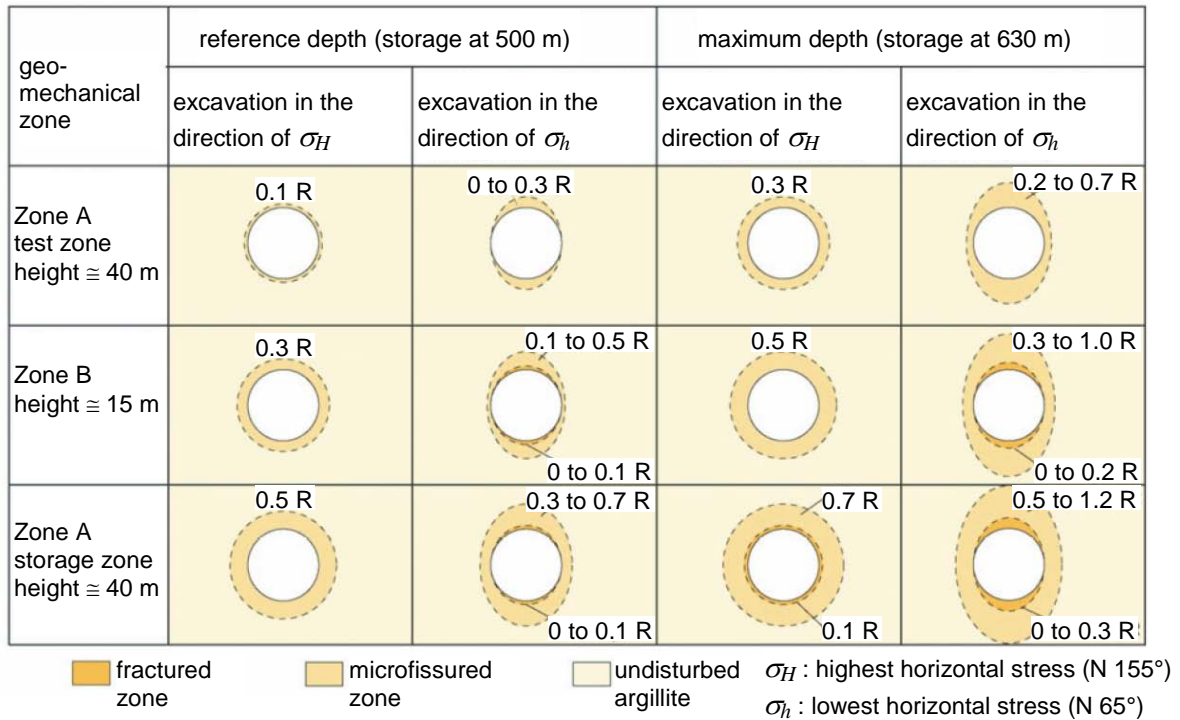

Fig. 38 Calculated form and extension of the EDZ, variations depending on the stress field and depth /AND 05a/.

Hydraulic conductivities in the inner Zone of EDZ were measured between 10^{-10} m/s and 10^{-8} m/s. A dependence on direction was not detected. These values are about three up to five orders of magnitude above the hydraulic conductivity of undisturbed claystone /AND 05a/. In the outer zone hydraulic conductivities of about $5 \cdot 10^{-11}$ m/s were measured meaning an increase of two orders of magnitude in comparison to the undisturbed rock. In contrast to the inner zone which is characterised by an isotropic conductivity microfissures in the outer zone may have preferential spatial orientation. The resulting degree of anisotropy is very difficult to predict /AND 05a/.

Structural changes of similar magnitude had also been measured during shaft-sinking through a marl formation. Conductivity increased within 1 m from the shaft wall about two orders of magnitude in comparison to the undisturbed rock /WIL 03/.

While the characteristic value for the hydraulic conductivity in each of the two zones can produce a first approximation of the real flow field, a more precise description would include a more elaborate dependence of the conductivity on the distance from the drift wall. An indication for such relation could be the fracture connectivity. Results

from a realistic fracture model yielded the structure of the fractures in the EDZ from which the connectivity could be derived as function of distance from the drift wall are shown Fig. 39. In this case the greatest density of fracture connections and thus the greatest conductivity was found in the immediate vicinity of the drift wall /AND 05a/.

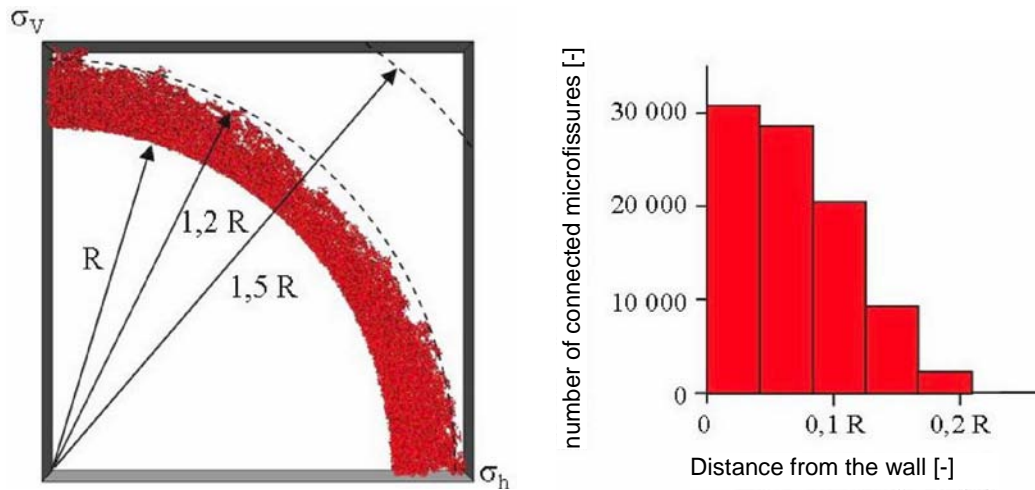

Fig. 39 Model results for the structure of the EDZ and for the fracture connectivity /AND 05a/.

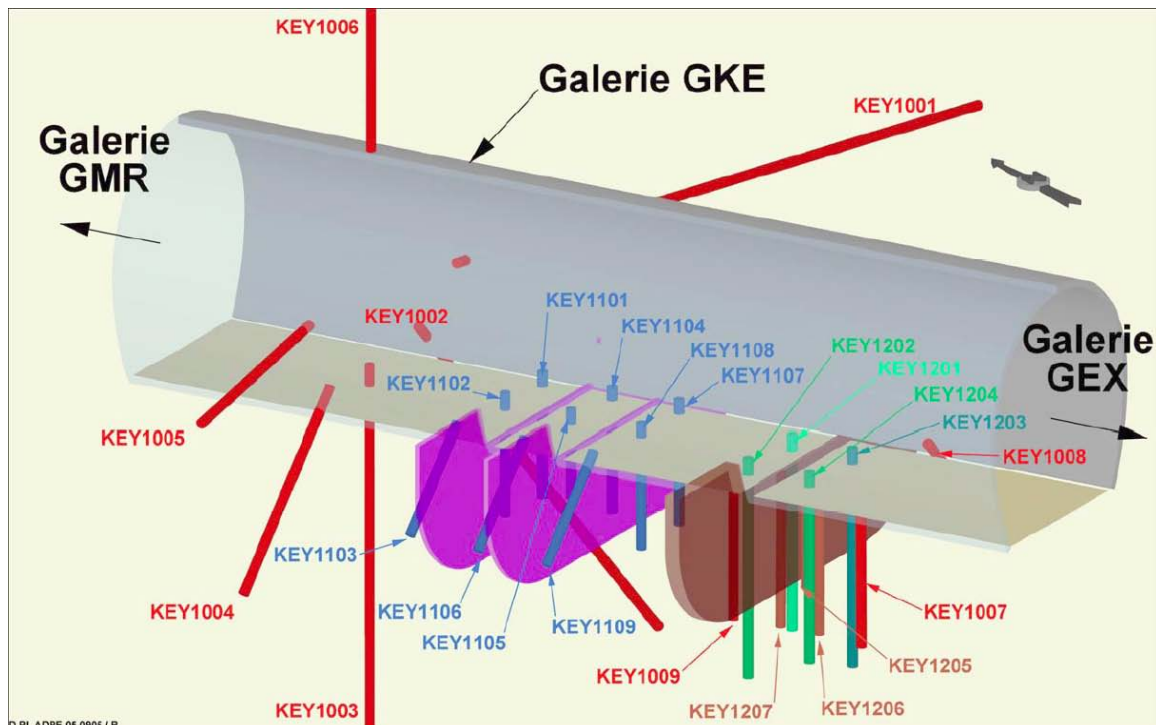

Fig. 40 Location of boreholes in the KEY-experiment /ARM 06/.

The reduction of the hydraulic conductivity close to the drift wall measured in the Opalinus clay at Mont Terri or in the granite at Äspö is apparently not considered for the Callovo-Oxfordian at Bure. However, the model results appear to be confirmed by conductivity measurements performed in the KEY-experiment /ARM 06/.

Boreholes were drilled from the connecting drift GKE in different directions, see in Fig. 40. Hydraulic conductivity was measured in the boreholes KEY1001 through KEY1006 (red) as well as KEY1101 through 1109 (blue); all results are compiled in the graph in Fig. 41 as function of distance from the drift wall. The data indicates a trend similar to the fracture connectivity shown in Fig. 39.

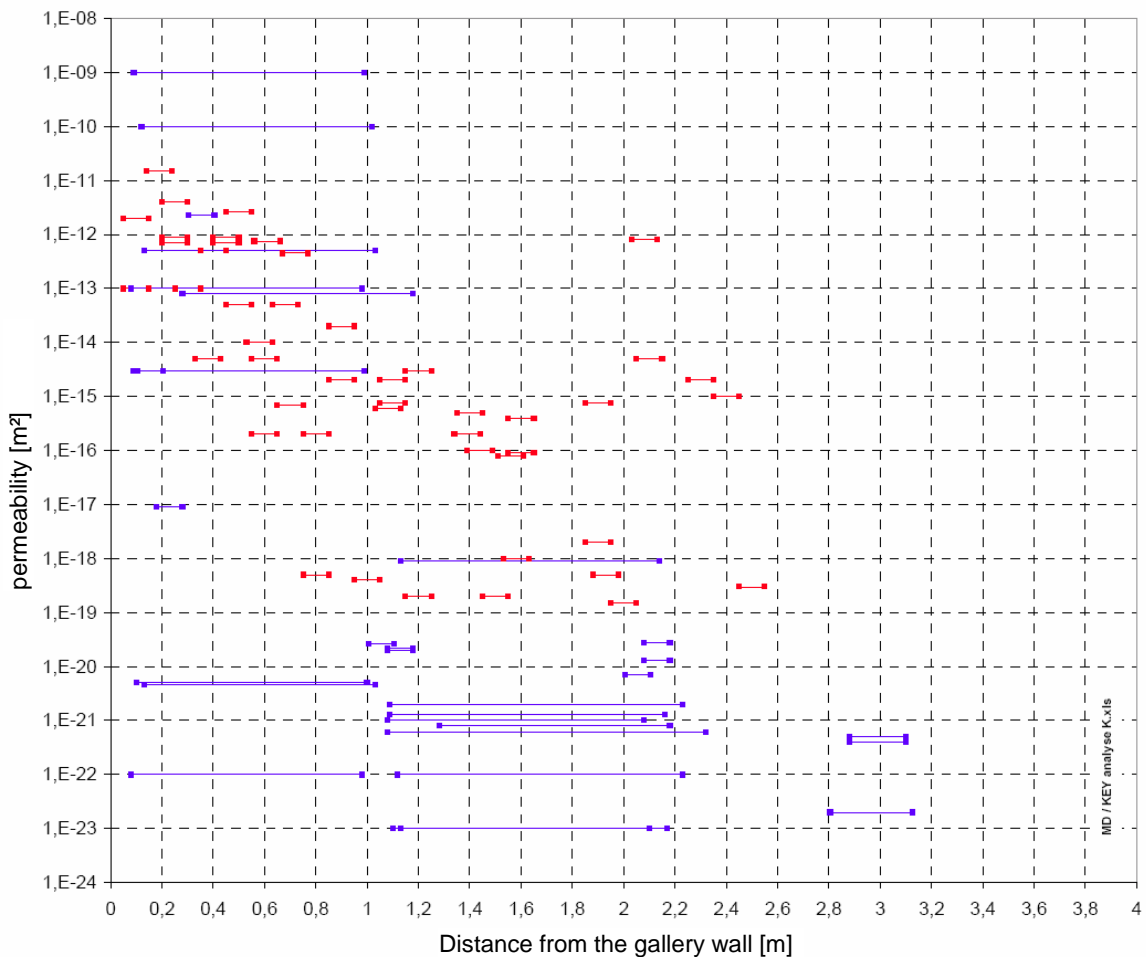

Fig. 41 Hydraulic conductivity from the KEY-experiment /ARM 06/; data from boreholes KEY1001 through KEY1006 in red; from KEY1101 through KEY1109 in blue, cf. Fig. 40.

However, the values of the hydraulic conductivity are considerably higher than all other reported values. The reason for that remains unclear. Therefore, data from /ARM 06/ are not included in the concluding compilation of Tab. 7.

The Tournemire site

The Tournemire site differs in two important aspects from the sites in Bure and in Mont Terri. It shows a higher degree of metamorphosis from claystone to shale which means significantly differing rock properties. Secondly, the URL at Tournemire consists of an old railway tunnel as well as of two recently excavated galleries. The railway tunnel has been excavated 125 years ago while the galleries exist now for five and twelve years, respectively. Therefore, the development of an EDZ over a comparatively large time can be investigated and compared with a recently created EDZ. One difference between the old and the new galleries exists, though, in that the railway tunnel had been lined with limestone masonry.

Big structural differences were observed between EDZ in the tunnel and in the new galleries. While fractures in the galleries were parallel to the bedding plane of the claystone the fractures in the tunnel were parallel to the tunnel wall. The latter structure is compared to onion skins in /REJ 06/. Fracture density is high, and the fractures are homogeneously distributed. The different fracture orientations are depicted in Fig. 42.

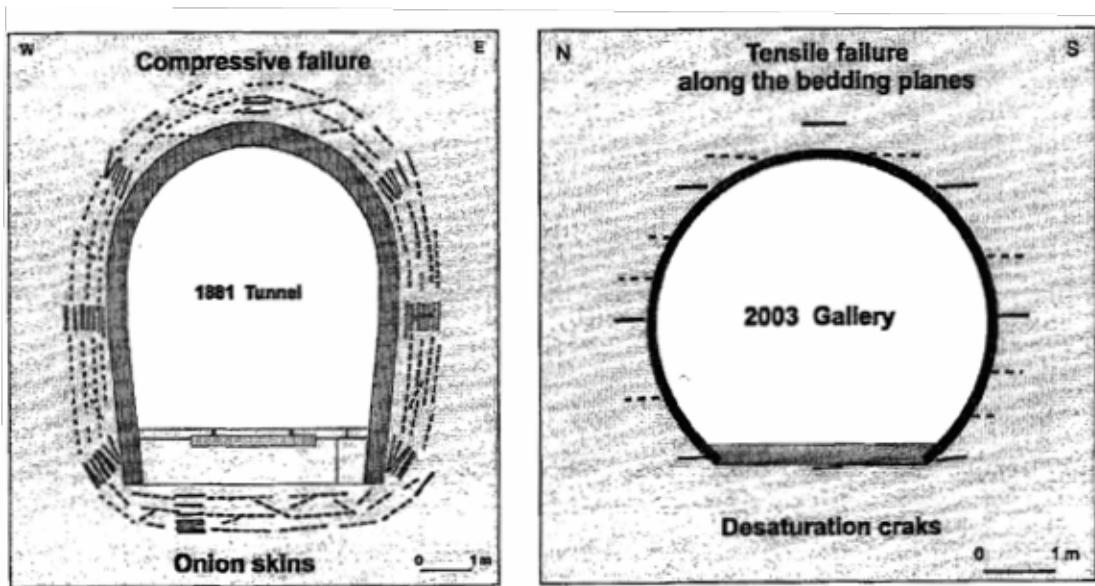

Fig. 42 Conceptual models of the EDZ in Tournemire; for the old railway tunnel (left) and for the gallery from 2003 (right) /REJ 06/.

The EDZ at the Tournemire site extends about 1.5 to 2 metres beyond the drift wall /REJ 06/. In relation to the drift radius R this relates to a thickness of 0.2 R. Desaturation of the rock has been observed to go even deeper. The referring values are compiled in Tab. 6.

The undisturbed claystone at Tournemire shows a permeability of 10^{-20} m² up to 10^{-18} m² /ALH 03/ and a porosity of 6 % to 9 % /REJ 06/. While in the laboratory hydraulic conductivities have been measured in a somewhat lower range between 10^{-15} m/s and 10^{-14} m/s, a value of 10^{-13} m/s is given in /REJ 06/.

In the EDZ permeabilities up to 10^{-12} m² were measured up to a distance of 1 m from the wall in case of the tunnel and up to a distance of 0.5 m in case of the gallery from 2003. Beyond this zone the permeability was estimated between 10^{-16} m² and 10^{-17} m². However, these values correspond to the lower limit of the measuring method /REJ 06/, so the actual values could be lower.

Tab. 6 Thickness of the EDZ and the zone of de-saturation for the tunnel and the two galleries at the Tournemire site /REJ 06/.

	railway tunnel (1881)	gallery (1996)	gallery (2003)
Thickness of the EDZ	0,22 R	0,20 R	0,16 R
Thickness of the zone of de-saturation	0,3 – 0,6 R	0,2 – 0,4 R	0,2 – 0,4 R

4.1.2.3 Evolution of the EDZ

General remarks

According to /BEP 03/ the development of the EDZ during operational period is influenced by drying, creep, oxidation of pyrites and temperature increase. In the post-closure period different processes than in the operational phase take effect, mainly re-saturation of the host rock and temperature development. These processes have influence on

- mechanical degradation and chemical evolution of the lining,
- fluid pressure build-up in the repository,
- pore pressure build-up, total and effective stress evolution,

- rock mass re-saturation, and
- bentonite seal saturation.

Understanding of these processes including onset and temporal development is essential for the safety analysis of the post-operational phase /BEP 03/. Important for the development of the hydraulic properties of the EDZ are the following processes /BLU 05/:

- swelling of the host rock in the unloaded area,
- disintegration of the rock in part of the EDZ,
- increase of host rock creep, and
- swelling of the buffer in case of smectitic clay buffer material.

Series of in-situ tests and laboratory investigations has shown that the initial hydraulic conductivity in the EDZ decreases up to 4 orders of magnitude during the first 3 years of re-saturation /BLU 05/. However, a complete sealing has not been reached in any test to date. Among the most prominent tests are the EH-experiment (Self-healing-experiment), e.g. /MEI 02/, and the two in-situ tests (long-term plate load experiment und long-term dilatometer test) that have been performed in the framework of the SELFRAC-project /BEF 06/ at Mont Terri. Based on the observed trends it is expected that the hydraulic conditions of the undisturbed claystone are reached again, either in few years /BLU 05/ or over longer time period /AND 05b/.

The Mont Terri site

Two experiments performed sequentially at the same location, the EH-experiment and the subsequent long-term plate load experiment of the SELFRAC-project, aimed at investigating the healing process of the EDZ addressing two specific processes. The first process concerns air-filled fractures that develop close to the tunnel wall during operation due to drying by ventilation. It was expected that water enters these fractures after backfilling and sealing because of their high permeability which then leads to swelling and partial closure of the drying fractures. This process was simulated by injecting water in the EH-experiment.

The second process - investigated in the long-term plate load experiment - refers to the adjacent bentonite buffer which would also swell after contact with water. Exerting pressure on the EDZ the buffer would also contribute to closing the fractures. The effect of the bentonite was simulated 800 days after beginning of the EH-experiment by two steel load plates at opposing sides of the drift wall, connected and pushed apart by hydraulic jacks. The applied stress was increase step-wise up to 4.8 MPa.

Hydraulic tests were performed periodically during both experiments in order to quantify the decrease of transmissivity in the EDZ. The results are compiled in Fig. 43. Further hydraulic tests were performed after cancelling the mechanical load. In Fig. 44 the complete load history is related to the measured hydraulic conductivity.

Without back pressure in the drift the transmissivity decreased with time from $5 \cdot 10^{-7}$ down to $2 \cdot 10^{-9}$ m²/s over 800 days /NAG 02a/. With back pressure the hydraulic conductivity decreased considerably faster from $2.1 \cdot 10^{-9}$ m/s to $4.2 \cdot 10^{-11}$ m/s over 140 days. Closer examination of the data yielded even $1.3 \cdot 10^{-11}$ m/s for the lower value /BEF 06/. Thus, re-sealing of the EDZ can be enhanced by swelling of buffer material.

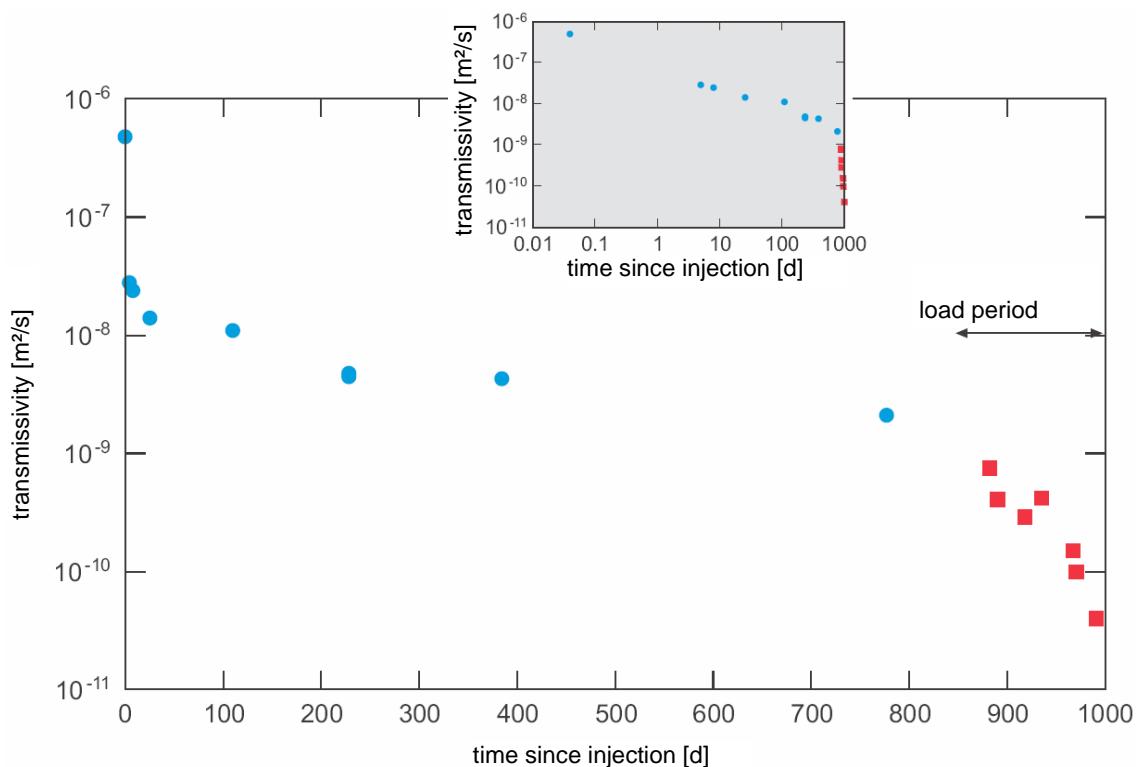

Fig. 43 Decrease of transmissivity in the EDZ in an open drift (blue circles) and including simulated swelling pressure of a bentonite buffer (red squares) /NAG 02a/.

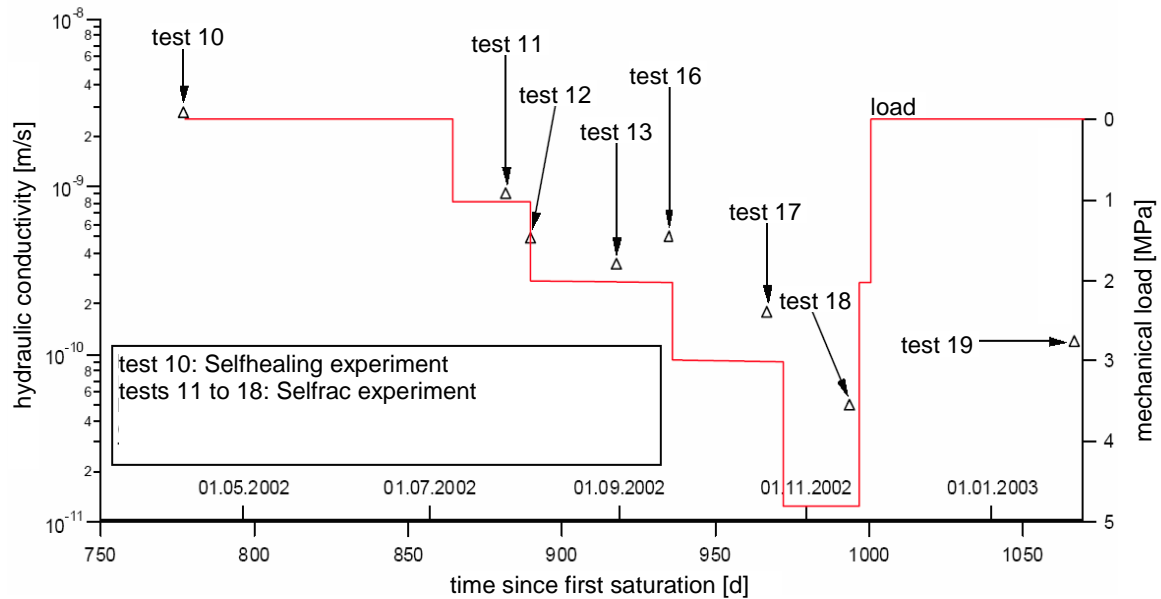

Fig. 44 In-situ measurements of fracture test sealing in the EDZ in the Opalinus clay; mechanical load (red line), hydraulic conductivity (triangles) /BEF 06/.

The structural changes during this sealing process are apparently only partially reversible. The hydraulic conductivity measured in a last test after removing the mechanical load equipment did not reach the initial value again. The measured value of $1.0 \cdot 10^{-10}$ - $1.5 \cdot 10^{-10}$ m/s lay about one order of magnitude below the initial value.

Laboratory tests were also performed parallel to the in-situ experiments. Intact samples were artificially fractured by applying tensile stress and then brought under a pressure of 4.5 MPa which relates to the in-situ stresses. Hydraulic conductivity of the samples was measured periodically over a period of 10 months. The results are shown in Fig. 41 Fractures from tensile stresses in the Opalinus clay cause apparently a large increase of hydraulic conductivity even if these fractures are compressed under a load of 4.5 MPa. The load, however, initiated a slow sealing process which let hydraulic conductivity decrease about two orders of magnitude over an 8 months period. Thus, sealing took longer in the laboratory than in the field but the samples in the laboratory had not been wetted before applying the pressure.

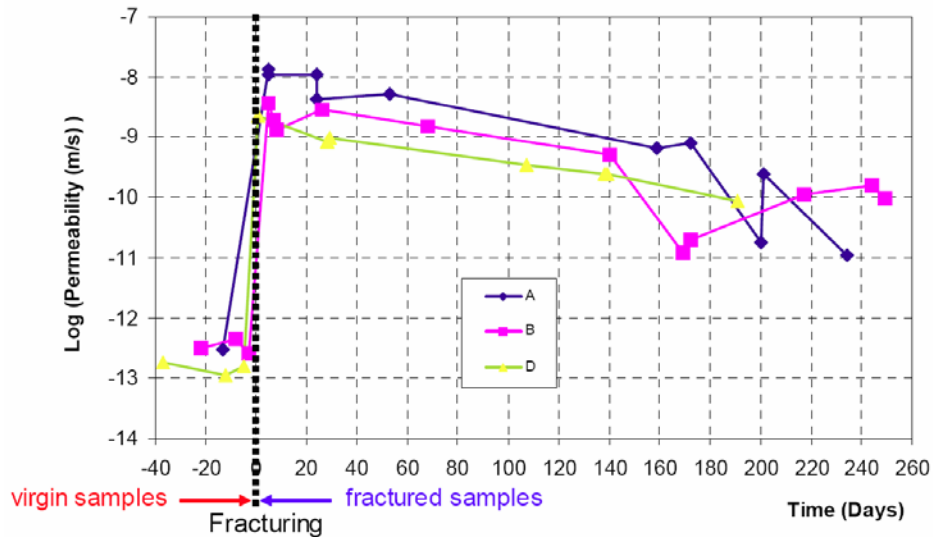

Fig. 45 Laboratory measurements of fracture sealing in the Opalinus clay /BEF 06/.

It must be mentioned finally that the artificially produced cracks were still clearly visible at the end of the laboratory tests. After removing the samples from the measuring equipment they could be divided at the former fracture plane without effort /BEF 06/. While an effect of sealing was demonstrated by the tests a healing could not be observed. At the end of the SELFRAC-project it was concluded that the process of healing for claystone is not fully understood.

Model calculations about the long term behaviour of the near-field yielded a porosity for the EDZ of 18 - 22 % depending on the degree of compaction of the bentonite buffer /NAG 02a/. The calculations included the processes of creep and swelling of the rock as well as swelling of the buffer. They showed that the swelling claystone compact the buffer until equilibrium is reached between the rock pressure in the far-field and the swelling pressure of the bentonite. In these calculations the compaction of the buffer material is caused only by dilatancy of the rock in the EDZ.

For long-term predictions it is assumed that maximum hydraulic conductivity in the EDZ will be about 10 times higher than in undisturbed rock. However, the hydraulic conductivity falls below 10^{-10} m/s in a few years after the bentonite buffer is fully saturated, thus, exerting a swelling pressure on the EDZ /BLU 05/.

The Bure site

For a repository in the claystone at Bure site it is assumed that a gap remains at the top of a drift between backfill and host rock. In case of high level waste disposal it is expected that this gap closes in about 100 years due to creep of the claystone and swelling of the buffer. After closure of the gap it takes up to few centuries until maximum sealing in the EDZ is reached. Closure of the gap is accompanied by a temporary expansion of the EDZ /AND 05a/. No information is available about the extent of this expansion.

The same applies to permeability and porosity of the sealed EDZ. However, for the numerical models including the EDZ no full healing of the EDZ is assumed. In /DUV 03/ the permeability of the EDZ is taken to be 100 times higher compared to undisturbed rock.

The Tournemire site

For the two galleries at the Tournemire site it could be shown that the microfractures parallel to the bedding plane were unsaturated. This indicates that a phase of desaturation and concurrent shrinkage of the claystone commences immediately after excavation. Shrinkage leads to tensile stress in the rock and finally to fracturing orthogonal to the direction of lowest tensile strength. This process explains fractures and spalling in freshly excavated galleries /REJ 06/.

Like the more recently excavated galleries the old railway tunnel is also ventilated and can thus provide only indications about the evolution of the EDZ during the operational phase. But here the situation is more complex. The onion skin structure of fractures in the EDZ of the railway tunnel cannot be a consequence of this drying process. The effect is not yet understood. It is suspected, however, that it is a delayed coupled effect /REJ 06/. Water uptake via air humidity or liquid water could lead to swelling and to mechanical weakening of the rock. Due to an increase of humidity could an initially stable appearing excavation show signs of instability after years. This kind of development was also observed in the Opalinus clay at Mont Terri /MAR 03/. Fig. 46 exemplarily shows the highly non-linear relation between water content and strength of different claystones; the other claystones are unfortunately not identified in /MAR 03/.

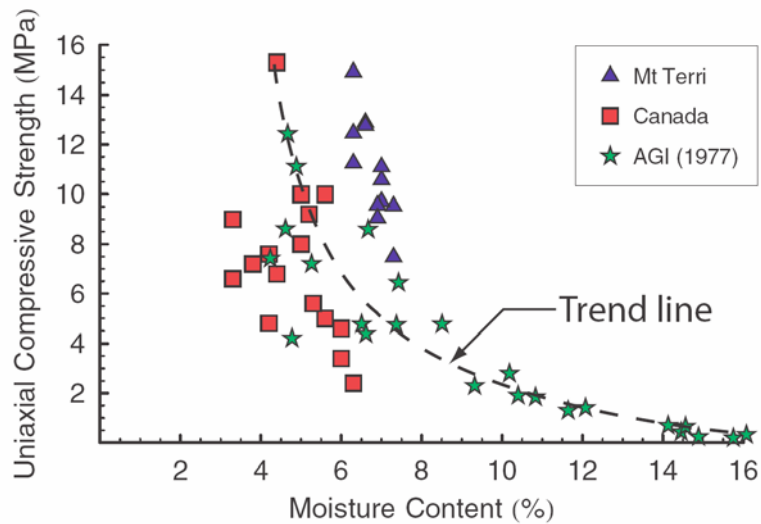

order to achieve a radionuclide propagation mainly through the geological barrier a certain “global sealing permeability” must not be exceeded /BAU 04/.

To decrease the probability of significant flow and radionuclide transport through the EDZ a special design in the drifts is considered by ANDRA /AND 05b/. In this concept the EDZ is supposed to be disconnected by cuts in the drift walls with depth of 0.3 m that are filled with pre-compacted bentonite. Fig. 47 illustrates this design for drift seals including the aforementioned cuts. It is investigated at Bure in the framework of the KEY-experiment. The EZ-A-experiment at Mont Terri had the same objectives. However, the process of sealing the EDZ alone was considered by many participants of the *Cluster Conference* to be sufficient to impede advective flow through the EDZ effectively /BEP 03/.

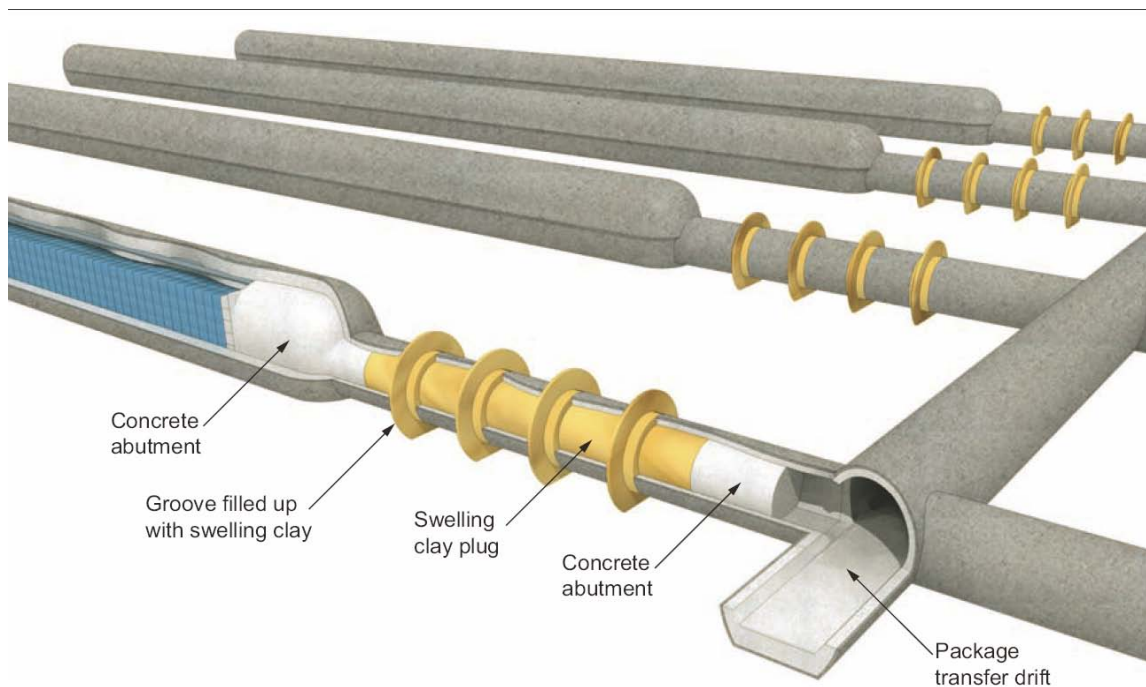

Fig. 47 Drift seal design by ANDRA, include concrete (white) and bentonite (yellow) /AND 05b/.

4.1.2.5 Summary and Conclusions

Generation and evolution of the EDZ in claystone is presently under intensive investigation. Work on the Opalinus clay and the Callovo-Oxfordian has been compiled and analysed in the present report. Three phases can be distinguished with view to different acting processes:

- generation of an EDZ,
- evolution in the open drift, and
- evolution after backfilling and sealing.

Valid observations and results can be gained in an underground laboratory for the first two phases since they last only for a limited period of time. Of additional help are investigations in tunnels of a higher age because they allow a deeper insight into the active processes. Generally, an inner zone directly at the drift wall and an outer zone adjacent to the inner zone with significantly different degree of disturbance could be identified. The hydraulic conductivity in the EDZ of a freshly excavated drift was found to be increased up to seven orders of magnitude in comparison to the undisturbed rock.

In the third phase after backfilling and sealing the conditions in a repository are radically changed which changes also relevant processes. The time that these processes have to take effect exceeds any reasonable observation period. Additionally, it seems to be unfavourable that the evolution of the EDZ is rather fast in the beginning but slow down with time. Therefore, steady-state conditions have not been reached in any experiment.

In case of the Opalinus clay measurements of the hydraulic conductivity ended at a value of two to three orders of magnitude above the value for the undisturbed rock. Measurements thus show trends and set limits for the final values. However, hydraulic data for the EDZ over the extreme periods of time in question are presently not available. Only expert judgement exists about the referring parameter values.

For the undisturbed claystone the permeability as well as the porosity is well known but, in contrast, hydraulic investigations of the EDZ concentrate exclusively on the permeability. The porosity in the EDZ has apparently not been measured, either immediately after excavation or later. What has been done are estimations based on

numerical models. In relation to the development of the size of the EDZ it is only reported that the EDZ shrinks as soon as claystone and bentonite barrier apply pressure on the EDZ by the process of swelling. All data collected from reports are compiled in Tab. 7.

In order to impede a possible advection of mobilised radionuclides through the EDZ even further the sealing concept of ANDRA foresees a disconnection of the EDZ by additional cuts around the drifts that are to be filled with pre-compacted bentonite. Model calculations of NAGRA, however, indicate that diffusion of radionuclides into the rock matrix will outweigh advection along the EDZ for long disposal drifts anyway.

All data collected here refer to claystone formations in Switzerland and France. In Germany there exist at least two options for the location of a possible repository in claystone, in the South in the continuation of the Opalinus clay formation and in the North in the lower cretaceous clays. Therefore, it is not possible to define a set of representative data for the EDZ of a generic German repository. While data for the Opalinus clay in Switzerland may be used with some justification in case of a site in Southern Germany the claystone in Northern Germany still requires some closer characterisation. But the compiled data in Tab. 7 provide at least some general indications:

- undisturbed claystone
 - hydraulic conductivity $\sim 10^{-14} - 10^{-12}$ m/s
 - porosity $\sim 12 - 18$ %
- initial values for the EDZ
 - hydraulic conductivity $\sim 10^{-5} - 10^{-10}$ m/s
 - porosity $\sim 12 - 18$ % (very little difference estimated)
 - thickness of the EDZ $\sim 0.1 - 1.25 R$; $R =$ drift radius [m]
- final values for the EDZ
 - hydraulic conductivity ~ 10 to 100 times the undisturbed conductivity
 - porosity $\sim 18 - 22$ % (depending on the degree of compaction of the buffer)

Tab. 7 Compilation of hydraulic data for three claystone formations³.

	Mont Terri/Benken	Bure	Tournemire
undisturbed claystone	hydraulic conductivity K [m/s], permeability k [m ²]		
	$K_{\min}=2.6 \cdot 10^{-14}$ m/s , $K_{\max}=1.2 \cdot 10^{-13}$ m/s /NAG 02a/, /ALH 03/ $K=2 \cdot 10^{-14}$ - $2 \cdot 10^{-12}$ m/s /BEF 06/	$K=5 \cdot 10^{-14}$ - $5 \cdot 10^{-13}$ m/s /AND 05a/	$k=10^{-18}$ - 10^{-20} m ² /ALH 03/ $K=10^{-13}$ m/s /REJ 06/
	porosity Φ [%]		
	$\Phi_{\text{Mont Terri}} = 15.6$ % /NAG 02a/ $\Phi_{\text{Mont Terri}} = 15 - 16$ % /BLU 03/ $\Phi_{\text{Benken}} = 12$ % /BLU 03/	$\Phi_{\text{total}}=18$ % ⁴ /AND 05a/	$\Phi=6 - 9$ % /REJ 06/
initial values for the EDZ	hydraulic conductivity K [m/s], permeability k [m ²], transmissivity [m ² /s]		
	$K_{\text{wall}}=10^{-7}$ - 10^{-8} m/s /MAR 03/, /BLU 05/ $K_{\text{wall}}=10^{-7}$ - $5 \cdot 10^{-7}$ m/s /NAG 02a/ $K_{\text{floor/roof}}= 10^{-10}$ m/s /BEF 06/, /NAG 02a/ $T_i=10^{-5}$ - 10^{-9} m ² /s /BOS 02/ $T_o=10^{-9}$ - 10^{-12} m ² /s /BOS 02/	$K_i=10^{-10}$ - 10^{-8} m/s /AND 05a/ $K_o =5 \cdot 10^{-11}$ m/s /AND 05a/	$k_i \leq 10^{-12}$ m ² /REJ 06/ $k_o \leq 10^{-16}$ - 10^{-17} m ² /REJ 06/
	porosity Φ [%]		
	$\Phi \leq 1,02 \cdot \Phi_{\text{undisturbed}}$ ⁵ /NAG 02a/	-	-
	thickness of the EDZ d [m]; R - drift radius [m]		
	$d_{\min}=0.10R$ /BOS 02/ $d_{\max}=1.25R$ /BOS 02/ $d_{\text{mittel}}=1.0R$ /BOS 02/	$d_{\text{mittel}}= 1R$ /AND 05a/	$d=0.16 - 0.22R$ /REJ 06/
	hydraulic conductivity K [m/s]		
$K_{\text{end}} \sim 10 \cdot K_{\text{undisturbed}}$ /NAG 02a/	$K_{\text{end}} \sim 100 \cdot K_{\text{undisturbed}}$ /DUV 03/	-	
porosity Φ [%]			
18 % < Φ < 22 % ⁶ /NAG 02a/	-	-	

³ indices "min" and "max" refer to the extreme values at anisotropy; indices "i" und "o" refer to the inner and outer zone of the EDZ.

⁴ Only half of the value cited is to be used for calculations of flow and advective transport in the Opalinus clay and in the Callovo-Oxfordian since only half of the pore space contains free water. Even significantly less of the pore space is accessible to gas flow.

⁵ Estimation based on model calculations.

⁶ Depending on the degree of compaction of the buffer; estimation based on model calculations.

4.2 Geochemical effects

4.2.1 Treatment of C-14 in spent fuel performance assessment

C-14 represents a dose relevant radionuclide in performance assessment. High amounts of C-14 are in particular contained in spent fuel elements, i.e. in the UO_2 matrix itself and in metal parts. Due to its relatively short half life of 5,730 years, the transport time through the repository system is of crucial importance for its contribution to the radiation exposure.

The transport properties are determined by the chemical form of C-14. As already described in /NOS 05/ there is some uncertainty about the chemical form of C-14 after mobilisation from the spent fuel, which is currently discussed on international level /JOH 04/. There are several experimental results indicating that C-14 released from metal parts (zircaloy, steel) occurs in form of small organic molecules, like carboxylic acids, aldehyds and alcohols /DEN 97/, /ZHA 93/. Concerning the chemical form in the UO_2 matrix the experiments indicate that C-14 exist as inorganic carbon. However, this needs to be confirmed, since most of the experiments have been performed under oxidising conditions.

The chemical form of C-14 is no issue of concern for vitrified HLW. In case of vitrified HLW carbon has been oxidised during the reprocessing and occur as carbonate. Furthermore the total C-14 radionuclide inventory in HLW is smaller than in spent fuel waste.

In order to investigate the impact of the chemical form of C-14 in consequence calculations for repositories with spent fuel in clay and salt host rock, simulations with different conceptual models with respect to the retention of C-14 have been performed.

In both formations reducing conditions are expected in the repository near field. In a repository in rock salt reducing conditions will be provided at least for several 1,000 years by the high amount of iron in the container material. In a repository in clay host rock, additionally, to the container material pyrite and organic matter in the bentonite and in the clay formation will buffer the reducing conditions over geological time frames. Therefore an (early) oxidation of organic carbon to carbonate in the repository is not expected.

Whether the small organic molecules are stable or whether microbial degradation occurs during their transport through the repository system is uncertain. In case of microbial degradation CH_4 and/or CO_2 will be formed, depending on the chemical conditions in the water, e.g. /RUE 04/.

Currently there are not enough data available to describe the sorption behaviour of small organic molecules in the repository system. Due to this fact, conservatively, organic C-14 is considered in current safety analyses to be very mobile, i.e. no solubility limits and no sorption on mineral phases in the buffer, backfill or geological formations are assumed. Finally it is assumed that organic carbon is oxidised in near-surface aquifers to CO_2 , i.e. the dose conversion factor for inorganic carbon can be applied. The same conceptual model is applied to long-term safety calculations for repositories with spent fuel waste in clay and rock salt.

For a potential repository in clay host rock the reference case described in TONI is considered by /RUE 07/. The calculation has been performed for a potential site in Opalinus clay in southern Germany. With respect to the radionuclide flux out of the formation only four radionuclides determine the maximum dose, namely the weakly sorbing radionuclides C-14, Cl-36, Se-79 and I-129, see Fig. 48. The solid line shows the case if C-14 is assumed to occur in organic form, i.e. its K_d -value in the bentonite and the clay formation is zero. Without retardation the C-14 peak occurs significantly earlier compared to the other three radionuclides, which are slightly retarded. In contrast, if C-14 is assumed to occur in the inorganic form (as carbonate), in bentonite solubility limit of $3 \cdot 10^{-3}$ mol/l and a K_d -value of $6 \cdot 10^{-5}$ m³/kg and in the Opalinus clay a K_d -value of $1 \cdot 10^{-3}$ m³/kg are applied, respectively. This relatively low K_d -value causes retardation of the peak by app. 100,000 years. Due to the increased transport time a much higher amount of C-14 is already decayed (only a fraction of $5 \cdot 10^{-6}$ of the initial inventory is not decayed after 100,000 years), when entering the biosphere. However, the radionuclide flux and also the effective dose rate are decreased by more than nine orders of magnitude. This is due to an additional broadening by diffusion operating over a longer time scale. Solubility limits for C-14 are not reached, i.e. the dominating effect is caused by retardation coupled with radioactive decay.

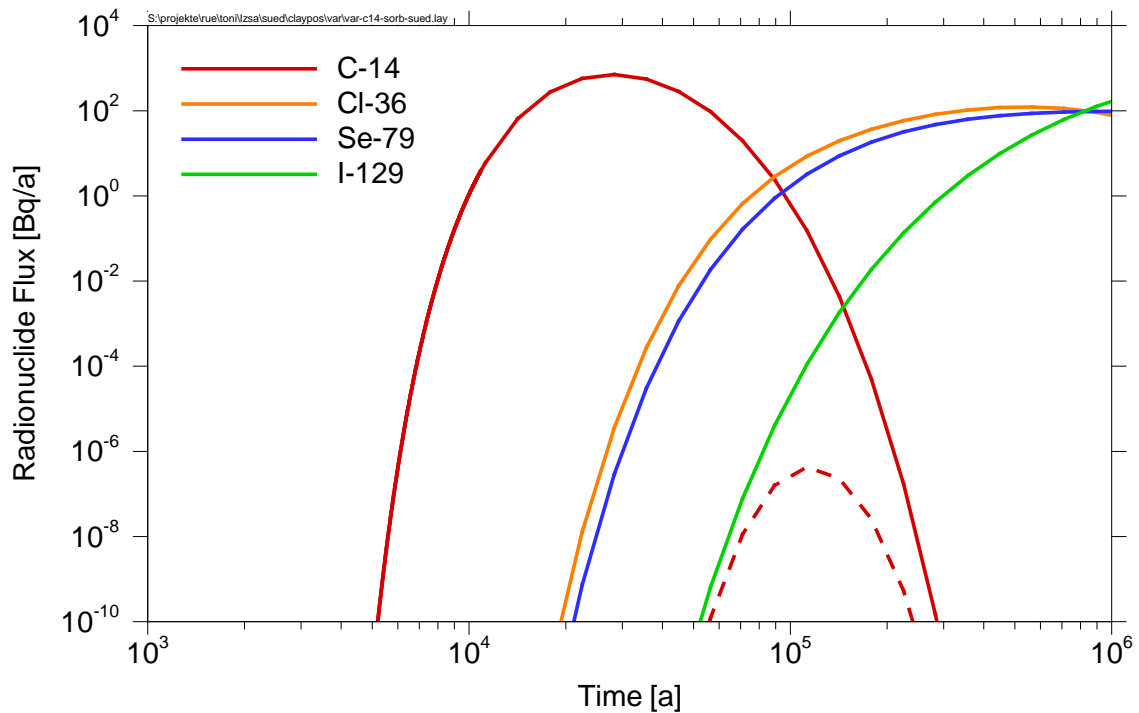

Fig. 48 Radionuclide activity flux out of the host rock formation for the reference case /RUE 07/: C-14 assumed to exist in organic form (solid line) or in inorganic form (dashed line)

For a repository in rock salt two altered evolution scenarios have been considered to investigate the impact of organic carbon on the potential radiation exposure, details see in /WOL 08/:

- “Failure of shaft and drift seals“: It is assumed that both the shaft and two drift seals do not meet the technical requirements so that their permeability is considerably higher than expected.
- “Brine inclusions“ inside the repository: It is assumed that two fluid reservoirs of 100 m³ not detected during the exploration open at the beginning of the post operational period.

C-14 in organic form is treated in the same way as for the repository in clay formations, i.e. no solubility limits in the near field and no retardation for the transport in the far field are considered. In contrast, for the C-14 in inorganic form solubility of 10⁻² mol/l and a K_d-value of 5·10⁻³ m³/kg are assumed. The results for both scenarios are shown in Fig. 49 and Fig. 50, respectively.

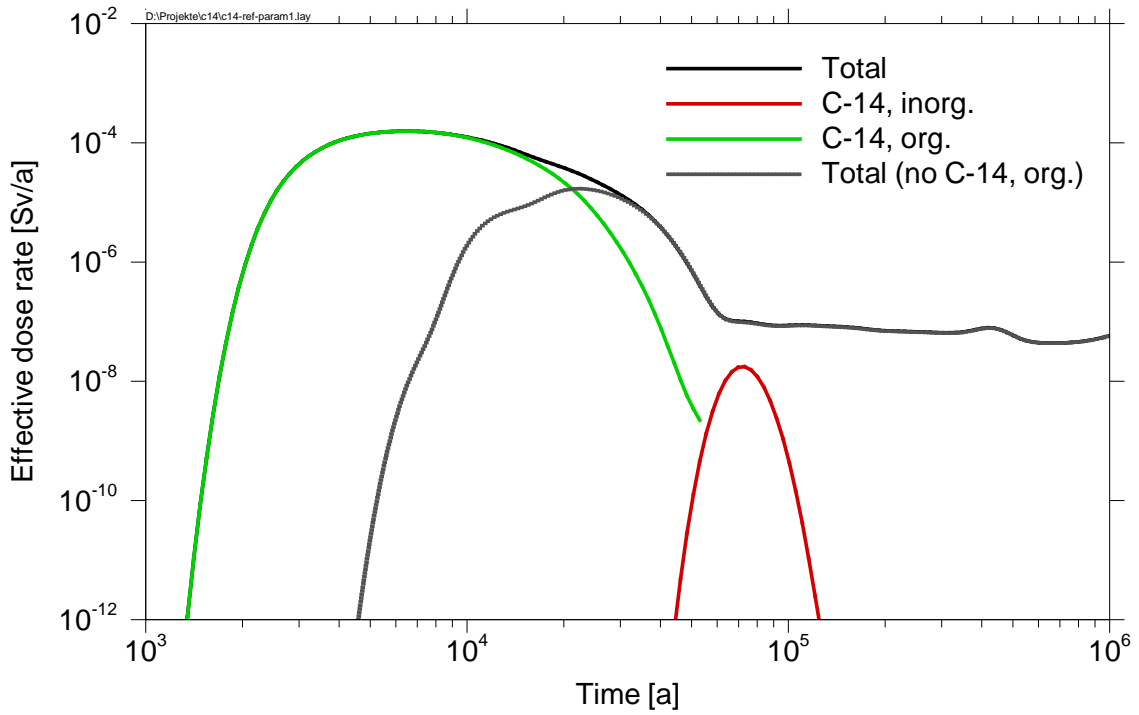

Fig. 49 Scenario "Failure of shaft and drift seals": Effective dose rate for the different forms of C-14 and impact on the total dose rate

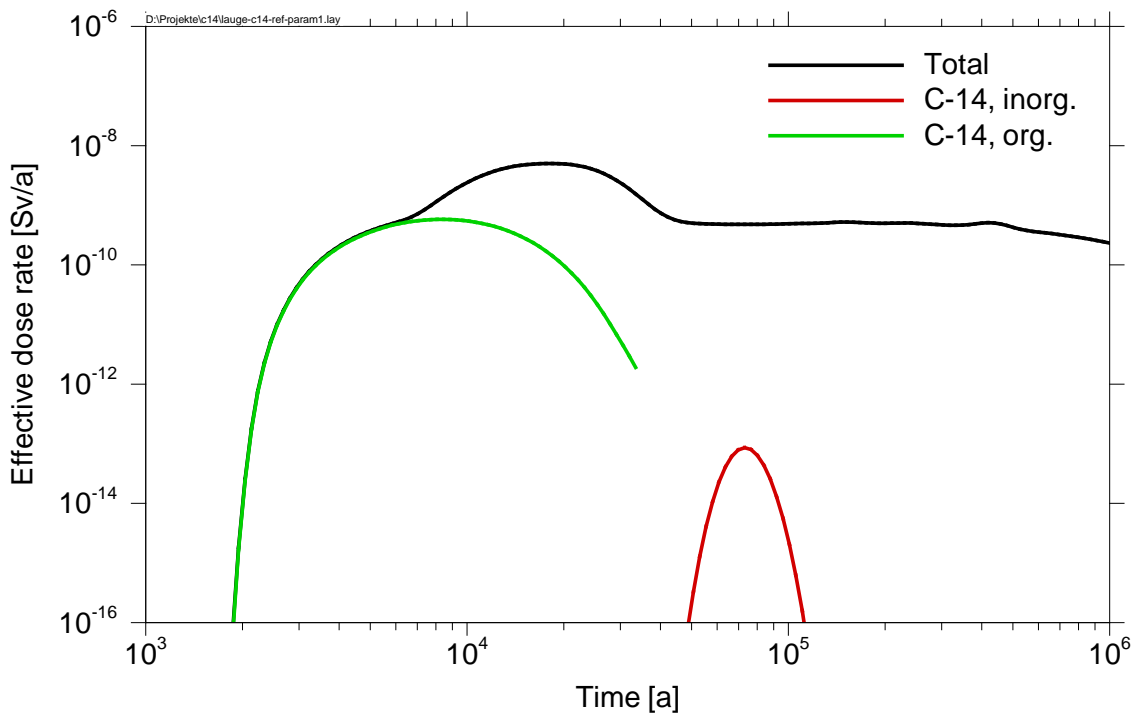

Fig. 50 Scenario "Brine inclusions": Effective dose rate for the different forms of C-14 and impact on the total dose rate

The red curve shows the effective dose rate for the assumption that all C-14 occurs in inorganic form, the green curve for the assumption that all C-14 occurs in organic form. The black curves show the total effective dose rates for the scenarios (solid line: C-14 in organic form, dotted line: C-14 in inorganic form (only Fig. 49)). The strong impact is clearly visible. Whereas inorganic C-14 does not notably contribute to the total dose, organic C-14 dominates the dose exclusively over early time periods. For the failure scenario it dominates over the first 20,000 years resulting in an increase of the maximum total dose rate by one order of magnitude. For the brine intrusion scenario it dominates over the first 8,000 years.

For both scenarios the maximum peak for C-14 in organic form appears to 6,000 - 8,000 years (green curve). Sorption of inorganic C-14 in the far field causes an increased travel time of app. 70,000 years; about twelve half lives of C-14. According to radioactive decay an effective dose rate reduction of C-14 by slightly more than three orders of magnitude is expected. For both scenarios the reduction amounts to nearly four orders of magnitude, i.e. the major reduction indeed originates from radioactive decay caused by increased travel time due to strong retardation. Only small contributions stem from dispersion and precipitation.

In order to quantify the impact of precipitation two calculations have been performed one with high solubility (1 mol/l) and one with the solubility limit 10^{-2} mol/l, see Fig. 51. The curves for solubilities of 1 and 10^{-2} mol/l are very similar. This shows that the impact is very low for this scenario for a solubility limit of 10^{-2} mol/l, i.e. only a very small fraction of C-14 is immobilised by precipitation. However, in the case of more alkaline conditions in the disposal areas, see chapter 4.2.2, the solubility limits for inorganic carbon might further decrease. For solubility limits of below 10^{-2} mol/l the impact of the solubility limit is significant; the reduction of the effective dose rates seems to be directly proportional to the reduction of the solubility limits in this scenario (not shown in pictures).

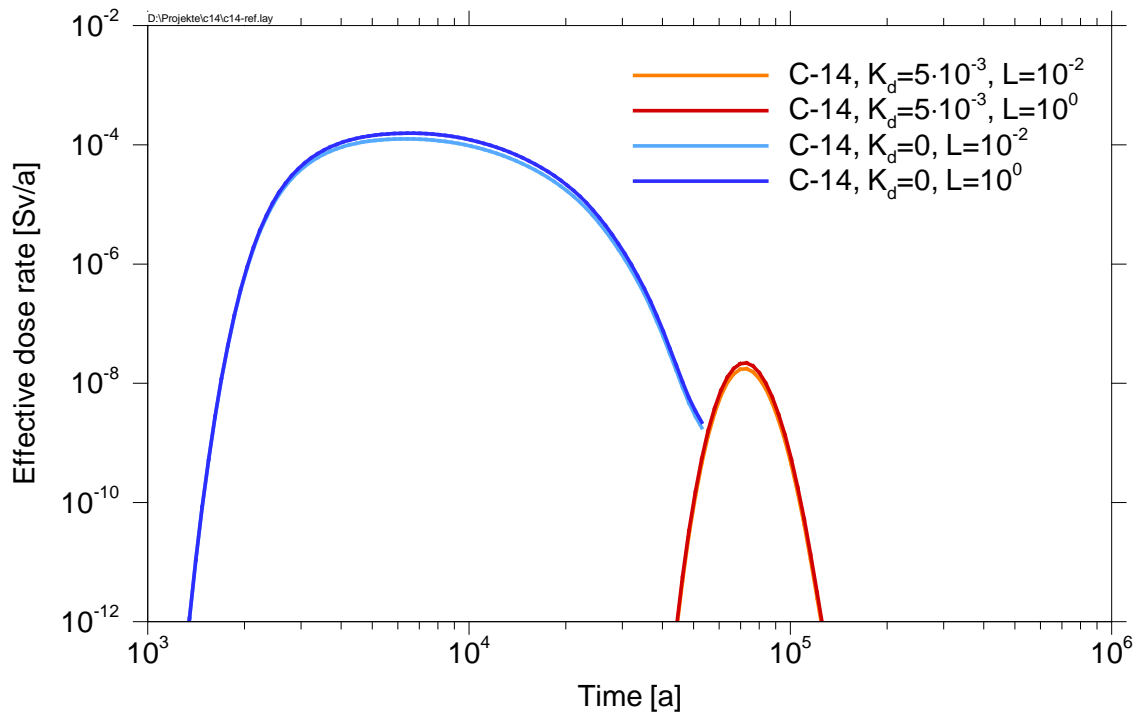

Fig. 51 Scenario “Failure of shaft and drift seals“: Effective dose rate for the different forms of C-14 in dependence of solubility limits. Solubility limits L in [mol/l], K_d -value in [m^3/kg]

Finally, Fig. 52 shows the effective dose rate applying the assumptions used in /NAG 02a/ for the distribution of C-14 to organic and inorganic form in different spent fuel compartments. In Tab. 8 the distribution of organic and inorganic C-14 in different parts of spent fuel is shown: C-14 in metal parts is assumed to occur in organic form, C-14 in the fuel matrix is assumed to occur in inorganic form. Since, in total, 72 % of the C-14 is contained in metal parts the organic C-14 dominates the effective dose rate. The curve is quite similar if the total C-14 inventory is assumed to be in organic form, see Fig. 49.

Tab. 8 Inventory distribution of C-14 forms on UO_2 matrix and metal parts and instant release fractions

	UO ₂ matrix [%]		Metal parts [%]		L [mol/l]	K _d [m^3/kg]
	instant release	matrix	Instant release	metal		
organic	-	-	14.4	57.8	1	0
inorganic	1.39	26.41	-	-	10^{-2}	$5 \cdot 10^{-3}$

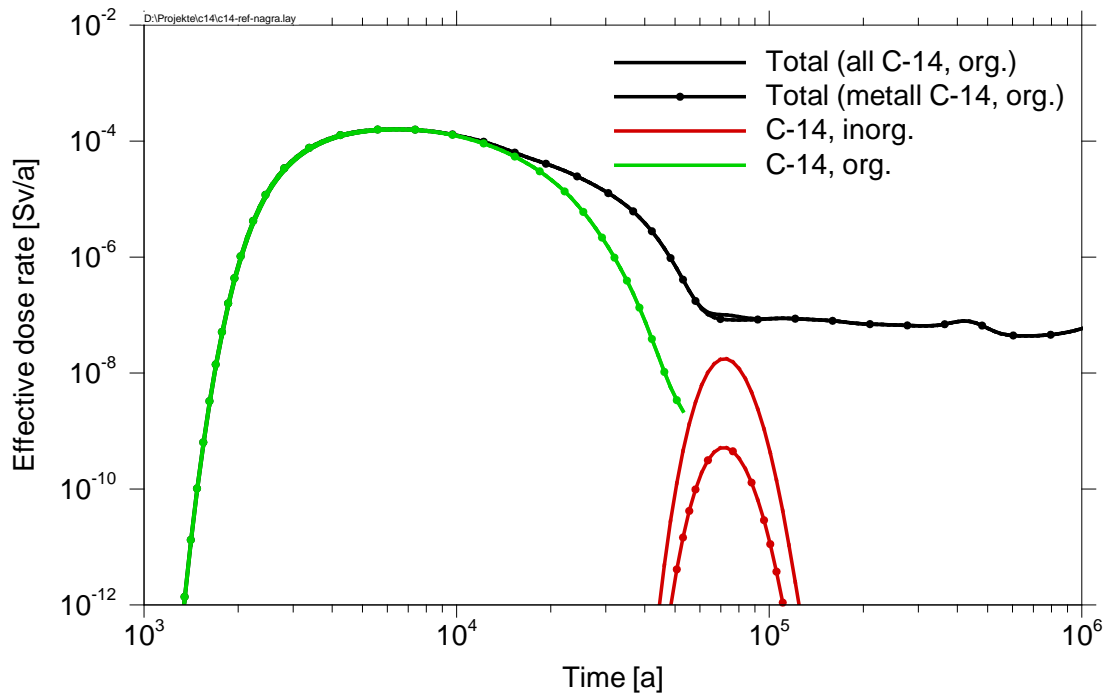

Fig. 52 Scenario “Failure of shaft and drift seals”: Effective total dose rate and dose rate for C-14 considering its distribution on organic and inorganic fractions in the waste (s. text for explanation)

The calculations for both host formations show the strong impact of the chemical form, in which C-14 occurs, on the effective dose rates. In the approach shown here, the organic C-14 was treated as an ideal tracer, i.e. not sorbing and not precipitating. In particular, the assumption of no sorption causes the major impact on the dose rate. However, many of short-chain organic molecules like carboxylic acids, alcohols and aldehydes might sorb on natural mineral phases, but representative data are not available. Shown by the calculations for repositories in clay and rock salt formations even a low K_d -value would lead to strong reduction due to decay of significant amount of C-14 during transport because of the relatively short half life of C-14, which is in order of typical travel times of ideal tracers through the host rock formation or the overburden. Therefore, it is necessary to perform sorption experiments with molecules of relevant sorbents in the repository system, i.e. backfill and/or geological barrier material.

In relation to microbial degradation of these molecules they will be transferred to CO_2 and/or CH_4 . For the former molecule a treatment as inorganic carbon is adequate and will lead to significant C-14 retardation in both rock formations. If CH_4 is the major degradation product the transport will occur without retardation. In this case it is

important to know how much CH₄ will be dissolved in water and be transported by the water pathway as shown above, and how much CH₄ will be released into the gas phase. The latter issue, in particular, the development of more realistic models for the transport in the gas phase will be an investigation issue of the future R&D project SIGAMES, see chapter 4.3.6.

For future treatment of C-14 actualised inventories need to be determined, too. This concerns the C-14 content in metal parts of spent fuel elements, where the nitrogen contamination needs to be considered in actual burn-up calculations. An update of the inventory is foreseen in the future R&D project WiGru6 /WIG 08/.

4.2.2 Impact of uncertainties in geochemical effects on long-term safety assessment

The objective of this study was to compile recently developed thermodynamic data for speciation of PA relevant radionuclides and new models for the source terms for vitrified high level waste and spent fuel in saline conditions. These were applied to describe the radionuclide mobilisation and release from two different emplacement areas of a repository in rock salt, namely a borehole with HLW canisters and an emplacement drift with Pollux containers. The study is described in detail /NOS 08c/; selected results are summarised in the following.

For the geochemical calculations the code CHEMAPP was applied /ERI 90/. Most of the thermodynamic data were adopted from FZK-INE database /ALT 04/. In the project this database was extended by complexation constants and solubility products for species of the elements Ra, Se, I, Fe, Ni, Mn, Sr, Cs, Mo and Nd.

At first the code and database were verified by calculations for selected actinides in specific geochemical environments and by comparison with the results of previous calculations of FZK-INE /KIE 00/. At second the dissolution of vitrified HLW and of spent fuel, respectively, have been modelled with and without material from steel containers to be present in the system. Typical ratios of volumes to masses were adapted from the expected conditions in an altered evolution scenario with early intrusion of brine into the emplacement areas. For each geochemical system the maximum element concentrations have been calculated. Sorption was not considered.

Uncertainties in composition of the brine, amount of brine, redox conditions and the thermodynamic data itself have been addressed in the calculations. The calculation results show that uncertainties in redox conditions strongly impact the solubilities of several redox sensitive elements like selenium or technetium with differences of up to six orders of magnitude. Previous experimental results from FZK-INE indicated that even for redox conditions where the reducing form of uranium U(IV) is expected the oxidised form U(VI) seems to be more common /KIE 00/. Obviously, for several elements the composition of the brine is also of strong impact for the solubilities. For example, the dissolution of HLW in MgCl₂-rich brine leads to pH-values of about 5, whereas in saturated NaCl brine the pH increases to values above 9. In particular, the actinide solubilities are strongly affected, e.g. the solubility of Th increases by four orders of magnitude in the more acidic MgCl₂-rich brines.

Uncertainty analyses concerning thermodynamic data have been performed for the systems HLW and spent fuel in MgCl₂-rich brines. Referring to the 16 % and 84 % quantiles ($\pm 1\sigma$) most of the calculated element solubilities lie within a range of about one order of magnitude. The lowest range was estimated for selenium, zirconium and strontium in the case of vitrified HLW. For these elements the solubility limiting phases are well known and the aqueous speciations are rather simple. In the case of spent fuel dissolution the range for selenium is much higher, since the uncertainties impacts the redox state.

In a further step the impact of the differences in element solubilities as well as the impact of the new source terms for vitrified HLW and spent fuel have been analysed in long-term safety calculations for a selected scenario assuming brine pocket near the spent fuel emplacement drift or near the HLW emplacement boreholes, respectively discussed in the R&D project ISIBEL /BUH 08a/. Additionally, pessimistic assumptions with respect to the permeability of shaft and drift sealings were taken into account.

The source term for spent fuel elements considers the radionuclide release from different fractions, namely the instantaneous release fraction, the metal parts and the fuel matrix. This source term was already improved in the project SPA, with respect to mobilisation rates for metal parts and spent fuel /LUE 99/. Further improvements according to /GRA 00/ resulted in an additional fraction, the zircaloy cladding, and considers slight changes in the inventories in the different fractions. The results show, that the impact of the new source term compared to the one used in the SPA project is marginal for the effective dose rate /NOS 08c/. However, considering the actualised

data for radionuclide solubilities from new geochemical calculations impact on the effective dose rate is visible, shown exemplarily for MgCl₂-rich solution and minimum solubility limits in Fig. 53.

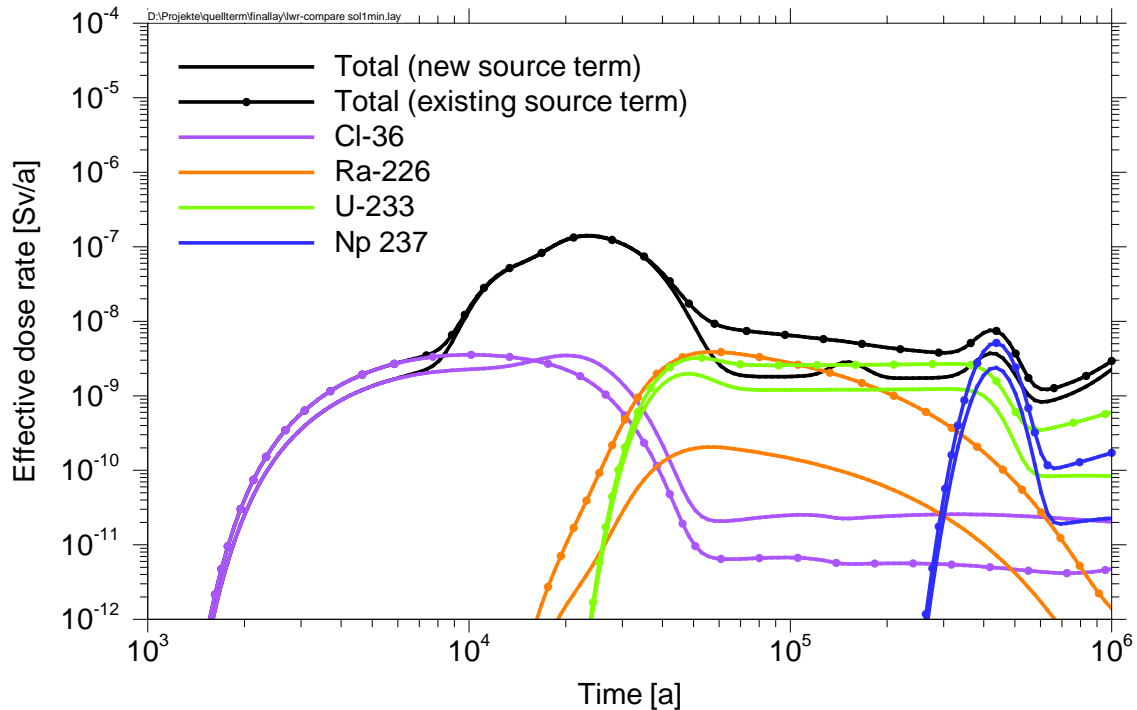

Fig. 53 Comparison of the existing and the new spent fuel source term for MgCl₂-rich solution and minimum solubility limits

The important difference in the overall effective dose rate occurs between 40,000 and 500,000 years. In this period the effective dose rate calculated with the new source term is considerably lower than results calculated with the existing source term. In this period the dominating radionuclides are these of the Np-series (Np-237 and U-233) and the U-series (Ra-226). The decrease for Np-237 and U-233 can be explained by lower solubility limits determined for the new source term. Since the effective dose rate for Ra-226 depends on the behaviour of the mother nuclides, in particular U-234, the decrease of the effective dose rate can also be explained by lower solubility limits for uranium.

The new source term for vitrified high level waste considers an additional process, i.e. the impact of silica concentration depending on the glass dissolution rate. The old source term considered one temperature dependent release rate, whereas the new one consists of two rates, the forward rate and the saturation rate. The forward rate is much higher than the saturation rate and directly correlated to the silica concentration

in solution /GRA 00/. If the silica saturation in solution is reached the rate approaches zero; then the radionuclide mobilisation is only determined by the saturation rate. This rate is slightly lower than the rate of the old source term, see Fig. 54. It has to be noted that the curves are superimposed by the canister failure occurring with a constant rate within 10 years.

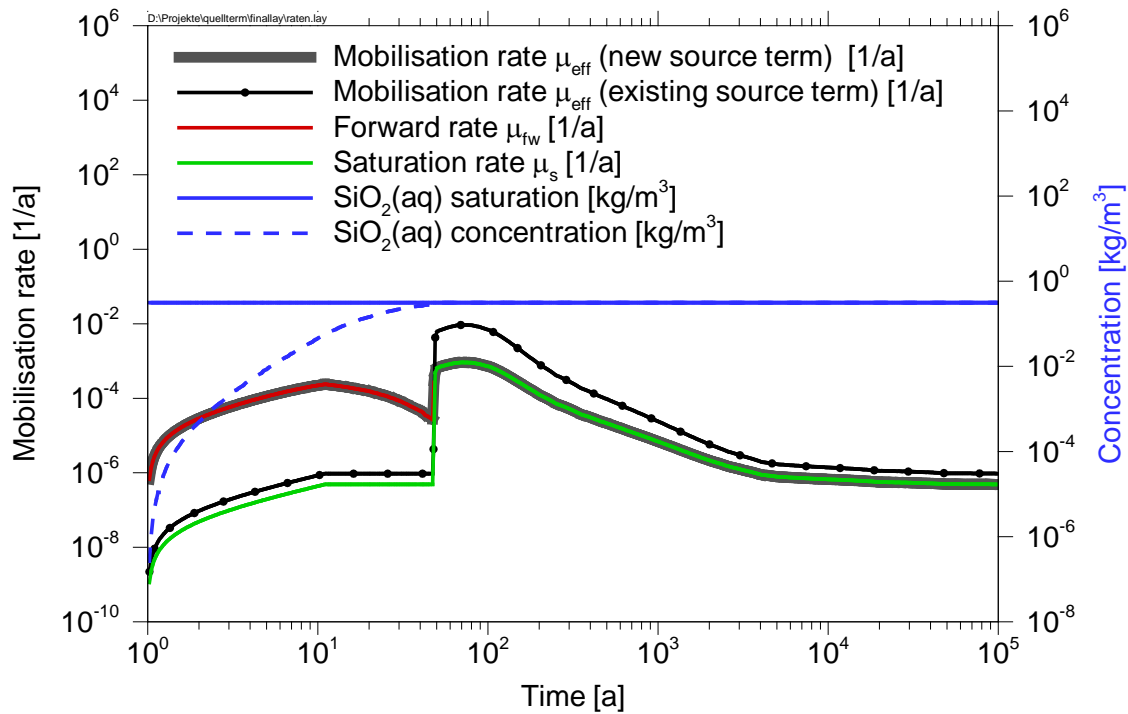

Fig. 54 Comparison of the different mobilisation rates for the existing and the new source term for HLW (silica saturation at T=200°C: 5.22 mol/m³)

The silica concentration increase after the first canister failed; in the regarded scenario the canister failure starts immediately at the beginning of the calculations. At this point in time the difference between the silica concentration in the borehole and the silica saturation is very large since the initial brine does not contain silica. The forward rate is about two orders of magnitude higher than both the saturation rate and the mobilisation rate of the existing source term.

At the beginning all rates slightly increase due to the failure of the containers in the repository. After 10 years all canisters are failed; at this point in time the forward rate decrease due to the ongoing dissolution of the glass matrix and the resulting higher silica concentration in the vicinity of the canisters. In about 50 years the actual silica concentration in the borehole has reached the saturation concentration and the forward rate is zero. The overall mobilisation rate of the new source term is now determined by

the saturation rate. As described above the saturation rate is in the same order of magnitude but always below the mobilisation rate of the existing source term. After 50 years all rates increase rapidly by more than two orders of magnitude caused by the fast temperature increase in the boreholes at this point in time. Due to the temperature decrease starting in about 100 years both rates decrease up to about 10,000 years if the system has achieved rock temperature.

Fig. 55 compare effects of the different mobilisation rates on the effective dose rate. The results can be summarized as follows: the higher forward rate, which dominates the new mobilisation rate during the first decades, has only small effects on the results. The fact that the saturation rate is lower than the existing mobilisation rate in general yields in lower overall effective dose rate with the new approach. The decrease of the effective dose rate is up to one order of magnitude.

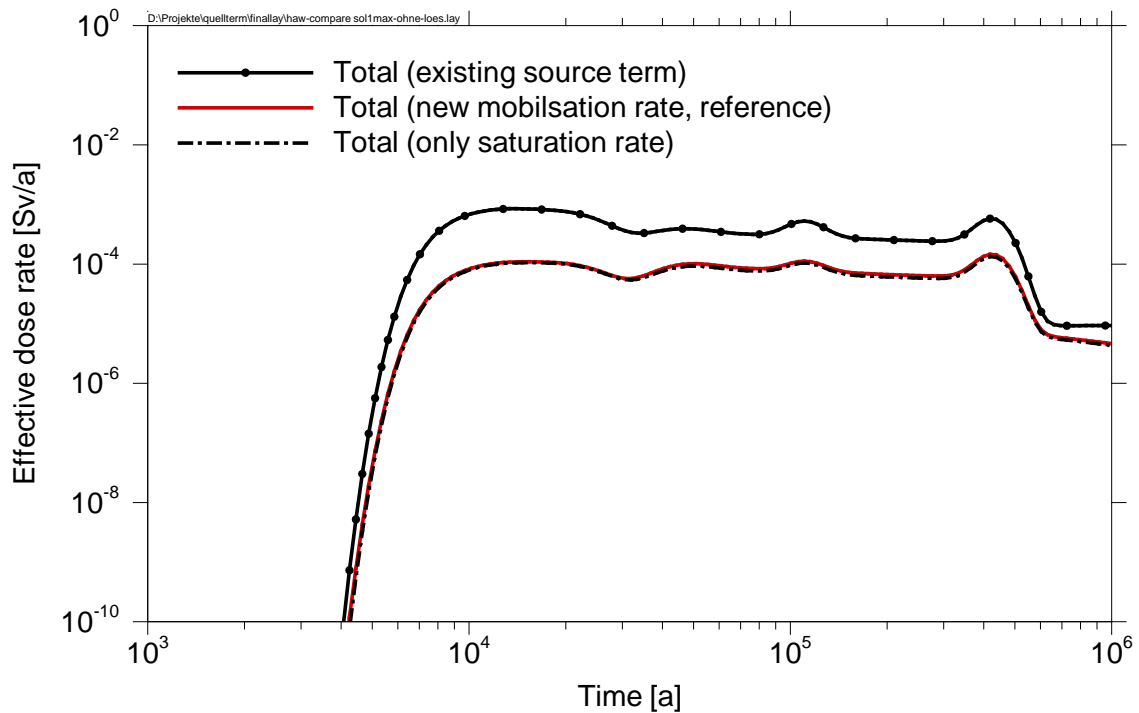

Fig. 55 Comparison of the existing and the new source term for vitrified HLW with regard to the effective dose rate (Mg-rich brine, maximum solubility limits)

Finally, a comparison between the existing source term and the advanced source term is carried out taking into account the changes in solubility limits, shown exemplarily in Fig. 56. The decrease due to the lower saturation rate is illustrated by the decrease of the curve for non solubility-limited Cs-135. The curves for Se-79 and Np-237 are even more decreased due to decreased solubility limits, whereas the increase of solubility

limits for uranium and neptunium lead to comparably lower decrease of effective dose rate.

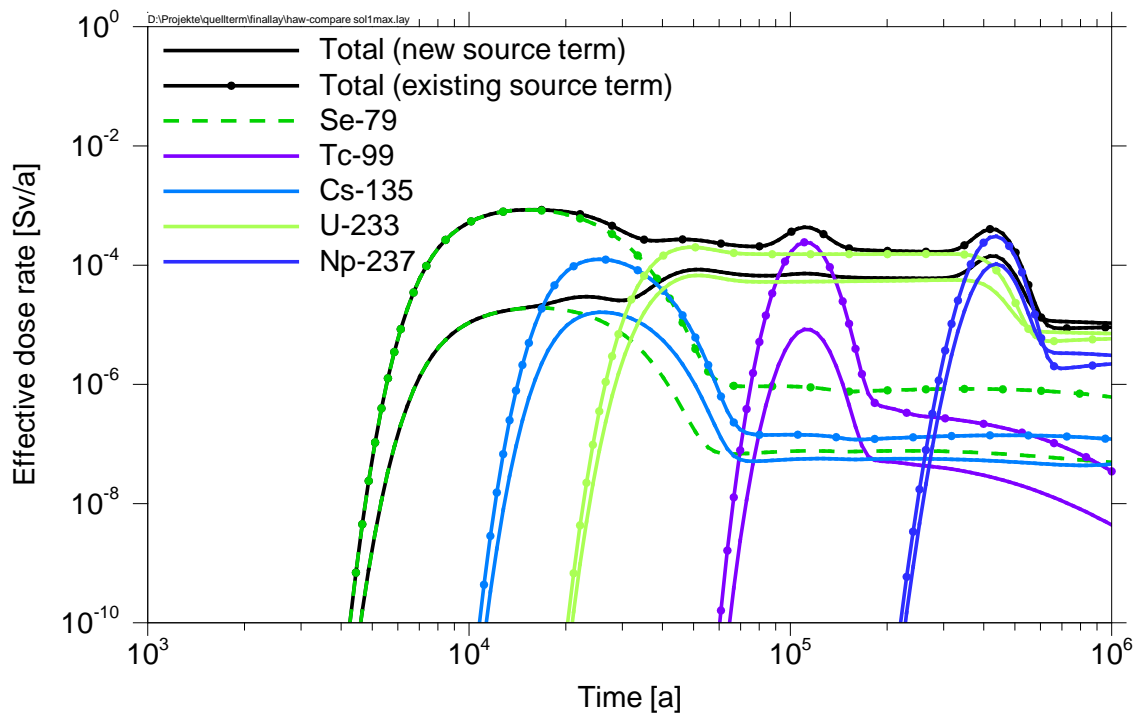

Fig. 56 Impact of radionuclides on the effective dose rate for the existing and the new HLW source term (MgCl_2 -rich brine and maximum solubility limits).

4.3 Gas workshop

Gases are generated in a repository for radioactive wastes by different processes. For a repository in rock salt, the prerequisites for occurrence of these processes are fulfilled both in the normal undisturbed evolution of the repository system and in the disturbed evolutions that are unlikely, but cannot be excluded. However, the different system evolutions do have a significant impact on the amount and the rate of the generated gases.

The state of knowledge on the gas issues related to final repositories in rock salt had been discussed on a workshop in May 1996, documented in /MUE 97/. In 10 years elapsed since the workshop a variety of national and international research projects have gathered new knowledge on that topic. Therefore, the actual state of the art with regard to the gas generation and transport in repositories for HAW in salt formations was discussed on a follow-on workshop in April 2007. Twelve institutions were invited

to present the current state of knowledge. The results of the workshop are well documented in /RUE 08/. The following six aspects discussed on the workshop are shortly summarised.

4.3.1 Gas generation

Gases can be generated in a repository for radioactive wastes by the following different processes:

- corrosion of metals: The corrosion of metals is primarily important with regard to the high amount of iron deposited with the waste containers. The anaerobic corrosion of iron is generating hydrogen gas by transforming iron into magnetite under the consumption of water; the maximum amount of Hydrogen produced is $0.535 \text{ Nm}^3_{\text{H}_2}/\text{kg}_{\text{Fe}}$. The kinetics of the process is not fully investigated. Therefore, it is not clear whether iron is completely converted into magnetite or only into an intermediate stage like iron oxide. Slow kinetics of the process might lower the maximum amount of gases produced.
- microbial degradation of organic substances: These is occurring by different processes which are depending on the supply of water and nutrients like nitrate or sulphate. Besides Hydrogen, also CO_2 , CH_4 or H_2S might be produced. In contradiction to a repository for LAW the microbial degradation can be neglected in a repository for HAW due to the low amount of organic material disposed of.
- Radiolysis: The water molecules are directly disintegrated by the ionising radiation producing hydrogen gas. The amount of gases produced by radiolysis is typically small compared to the one by metal corrosion.

As stated before, the presence of water is a prerequisite for processes generating gas. For a repository in salt rock in the normal undisturbed evolution the availability of water is limited. The different sources for water are

- the natural moisture in the rock salt of about 0.1 - 1%,
- the moisture which is disposed of along with the crushed salt backfill of about 2 kg up to 20 kg water per cubic meter of crushed salt, and
- small amounts of brine leaking through the shaft seal.

In the cases of a disturbed evolution scenarios much larger amounts of water are available. Then, additional sources of water are

- undetected brine reservoirs in the salt host rock, and
- water intruding from the overburden on different pathways, e.g. a broken shaft seal.

For the undisturbed evolution of a repository the amount of gases produced is typically limited by the availability of water, i.e. not all metals present in the repository will be converted. The amount and the inflow rate of water from the host rock formation are only known for timescales of a few years. The extrapolation on large timescales is a subject of high uncertainty. Therefore, these values need to be better determined for long time-scales.

4.3.2 Potential disturbances of the barrier integrity

New experiments performed by T. Popp (IfG Leipzig) indicate that the mechanics of gas transport in the salt host rock is similar to the one described for clay host rocks. According to this, the transgression of the rock pressure by the gas pressure due to gas production does lead to the creation of reversible pathways, i.e. an increase of the local permeability of the salt rock by widening the space between crystal surfaces.

In contrast to fracturing, this process does not disturb the crystal structure. The permeability of the salt rock is increased until equilibrium is reached between gas production and permeation. If gas pressure is decreasing again below rock pressure the initial permeability of the salt formation is restored. Borehole experiments have shown that gas transport over several meters does occur and also that the surfaces of the salt crystal structure are impregnated by gases, i.e. some of the gas are stored in the salt rock formation. These contradict the former theory of the formation of a so called “secondary porosity” of salt rock. However, insight knowledge about the exact process of gas transport and penetration depth into the salt formation does not yet exist.

4.3.3 Potential disturbances of the integrity of seals

Like the host rock barrier geotechnical seals can be affected by high gas pressures. The gas pressure might affect the permeability of the seal itself and the connection of

the seal to the host rock. Weak zones could lead to preferential flow of brines through or around the seal.

The new findings for the gas transport in the salt rock described above make it necessary to re-evaluate the processes impacting the seals, especially for the shaft seal. Model calculations by *Lux* have shown that the transport of gases occurs in direction of the fastest decrease of the main stress. For a shaft seal this might imply that the gas transport occurs around the seal.

Currently, it is unclear if gas pressure affects the integrity of geotechnical barriers. It has still to be evaluated whether technical measures can lead to a design of the seals to meet the requirements.

4.3.4 Transport of gases in the repository mine

As a consequence of the gas production, gas pressure gradients are built up in the repository mine. These pressure gradients are one of the driving forces for advective gas transport. If the mine will be dry, the gas transport is single-phase flow. However, if larger amounts of brine are present in the mine, the brine might either be displaced by the gas or the gas and the brine are transported together as two-phase flow. There exist mathematical models for the calculation of the two-phase flow in porous media, but it is not resolved if these are valid for very low porosities found in compacted crushed salt. In particular, the relationships between the following parameters of compacted crushed salt have to be known to calculate the two-phase flow:

- relative permeability and saturation,
- capillary pressure and saturation, and
- porosity and permeability.

The relationship of porosity and permeability of compacted crushed salt was determined in experiments down to porosity values of 5 %. For lower porosities this relationship is unknown. Until now, the relationship for higher porosities is extrapolated to smaller values and this approach has to be verified. Further, it has to be studied whether the porosity of crushed salt which decreases by compaction can fall below a certain value. This residual porosity could have an influence on the brine and gas

transport over very long timescales as they are accounted for in long-term safety assessments.

4.3.5 Impact of gases on the chemical milieu of the near-field

Gases produced in the repository can influence the geochemical milieu and, therefore, processes and effects in the repository. The major impacts are on the solubility and on the sorption behaviour of radionuclides and on the dissolution rate of the waste matrix. For HAW repositories Hydrogen is the only gas that has to be considered to affect the geochemical milieu. With increasing partial pressure of Hydrogen, the geochemical milieu will be more and more reducing, influencing the redox state of redox sensitive radionuclides like uranium, plutonium, neptunium, selenium and technetium.

The dependency of long-term safety relevant transport and retention parameters from the geochemical milieu has to be either assessed or conservatively estimated for the whole bandwidth of the geochemical milieu occurring in the waste repository. Currently, in long-term safety assessment the temporal variability of these parameters is not considered but it is used to estimate the most conservative value of the bandwidth. It has to be examined, if more realistic approaches can be applied in the future.

4.3.6 Transport of gases in the far field

Besides large amount of non-radioactive gases, small amounts of radioactive gases are produced in the repository. Some of these volatile radionuclides are already existent in the waste in the so called instant release fraction of the spent fuel, while others are generated by contact of waste with brine. For long-term safety the most important radioactive gases are $^{14}\text{CO}_2$ and $^{14}\text{CH}_4$. Gases containing C-14 can be produced by the contact of spent fuel with brine. C-14 exists at least partially in the form of short chain organic compounds that can be transformed into gas by microbial degradation.

The small amount of radioactive gases is diluted in the large amount of non-radioactive gases. Therefore, non-radioactive gases can act as carrier gas for radioactive gases. For the undisturbed evolution of a repository in salt rock it depends on the penetration depth of the gases into the host rock formation whether radioactive gases are released to the biosphere or not.

The transport pathway of the gases in the geosphere is still insufficiently investigated. On the one hand, the C-14 containing gas can be transported in gaseous form through the geosphere into the atmosphere. There it will be diluted in the atmospheric air, is participating the carbon cycle and can lead to a radiation exposure of the population. On the other hand, the gases can partially be dissolved in the geosphere water and used for food production. Since the groundwater flow is usually high, under certain circumstances all gases may be dissolved in the groundwater. This exposition pathway was considered in recent performance assessment calculations but highly simplified using conservative assumptions. More detailed investigations are needed to develop better models for the way, radioactive gases lead to potential radiation exposures of the population.

4.4 Impact of climatic changes

As discussed above a time frame for the safety assessment of radioactive waste repositories of about 1 Million years is proposed in the course of the revision of the German safety criteria. During such a time frame significant climate changes will occur. The objective of the study described here is to assess possible effects of climatic changes on a hypothetical repository in rock salt at a potential site in Northern Germany. Main focus was to study the impact on flow and transport processes in the overburden of the salt dome and on processes in the biosphere. It is not relevant for the normal evolution of a repository for heat generating waste if complete confinement of waste is reached by closure of all void volumes and transport pathways due to convergence of rock salt. However, in a safety case also altered scenarios with radionuclide mobilisation and release from the host rock, which cannot be excluded, need to be considered. Detailed and comprehensive descriptions of this investigation can be found in /NOS 08b/.

Due to the comprehensive information about geological, hydrological and near-surface characteristics available the Gorleben site was chosen as reference site for this study. The study comprised the following tasks:

- description of the main factors influencing the climate,
- evaluation of paleodata and compilation of ancient climates within the last several 100,000 years and their impacts on the reference site,

- brief discussion of climate models, their capabilities and prognoses performed for very long time scales relevant for performance assessment,
- identification and characterisation of potential future climate states at the reference site, and
- development of flow and transport models as well as biosphere models for the selected climate states and numerical calculations with these models to identify the impact of the respective climate states.

The primary factors affecting the long-term climate evolution for time scales >10,000 years up to one million years are the orbital parameters. The impact of the orbital parameters on the average insolation and the resulting cyclic changes between glacials and interglacials can be described by the Milankovich theory. Due to this theory, the occurrence of glacials is correlated with insolation minima in summer in 65° Northern altitude. Corresponding climate data from Antarctic ice cores can be reproduced by model calculations, assuming a transition into an ice age when summer insolation at 65° N fell below a critical value. Currently, the impact of anthropogenic factors on the climate evolution, especially of the greenhouse gases, raises increasing interest. It is discussed and shown by some model calculations that very high anthropogenic emissions in the next decades/centuries might cause long-term changes of the climate over several tens of thousands up to hundred thousand years. Furthermore, the amplitude of insolation (and therewith the insolation minima) is comparably low for the coming 50,000 years due to the currently low eccentricity of the earth's orbit. As a consequence most climate scientists do not expect the next glacial within the coming 50,000 years.

However, due to the high uncertainty covered with climate modelling, especially over such long time frames, special attention was drawn to paleo-climatological information from Quaternary and Holocene. During Quaternary cycles the time frame of glacials has exceeded those of interglacials by far. Last interglacials covered time frames of app. 10,000 years, whereas interglacials occurred over time periods of 60,000 to 100,000 years. The analyses also showed that there is no representative glacial/interglacial cycle for the considered site, but distinct differences between the cycles occurred.

While the Elsterian and the Saalian glacials caused a several 100 m thick ice cover above the investigation area for a time period of about 10,000 years, the inland ice

sheets of the last Weichselian glacial did not extend that far and left the site without an ice cover. During such glacial time periods without ice cover the periglacial conditions with permafrost down to depth of 40 m to 140 m have prevailed for several ten thousand years at the site. The formation of inland ice sheets led to strong subsidence of the sea-level, which caused values of about 110 m to 140 m lower than today at the past glacial maxima. The increasing distance of several 100 km to the sea led to an increasingly continental climate at the reference site.

There appeared also strong differences between the last interglacials. Whereas during the warmest period of the Holsteinian interglacial a transgression of the North Sea occurred at the investigation area, this was not the case during the Eemian Interglacial. Whether a future climate optimum will lead to a transgression of the site mainly depends on the amount of deglaciation of currently existing glaciers and inland ice sheets. A retreat of the whole ice volume existing today, which may not be expected according to the actual state of knowledge but occurred in earlier times, would result in a sea level rise of about 70 m. Due to the low elevation of the region Gorleben this might cause a maximum sea-level of 50 m above today's ground.

Flow and transport modelling in the overburden of the salt dome requires a large effort for the development of models and in particular high computing costs for modelling of each climate state. Therefore this part of the investigation was restricted to few selected models for extreme climate states, where significant differences in the models and the simulation results have been expected. Based on the paleoclimatic information discussed above the following climate stages have been selected:

- continuation of the climate conditions occurring today (as reference),
- a warmer interglacial state with a potential maximum sea level (leading to transgression of the reference site), and
- a glacial state accompanied by the formation of a glacier similar to a Weichselian one with formation of permafrost in front of the glacier.

In order to analyse the effects of the selected climate states conceptual models for flow and transport have been developed, implemented into the codes d^3f and r^3t , and exploratory calculations have been performed for the three climate states. A simplified hydrogeological model with an upper and lower aquifer and a separating clay aquitard in between was applied. Due to uncertainties about the location of hydraulic

connections in the argillaceous aquitard layer between the upper and lower aquifer two models, model 1 with only one and model 2 with two hydraulic windows in the aquitard, have been applied. The calculations have been performed for time periods of several 100,000 years. It was assumed, that each climate state did not change during this time. This allowed the detailed investigation of relevant effects and processes and principle differences in flow and transport caused by each climate state. For the transport calculations a limited number of radionuclides with different sorption properties were regarded and the impact of changes in groundwater mineralisation on the K_d -values was taken into account.

Exemplary results of this work are shown in Fig. 57 and Fig. 58. The results show that groundwater flow and radionuclide transport are strongly different in the models for the different climate states. Major differences occur in the dominating transport mechanism (advection vs. diffusion) but also in flow direction and radionuclide retardation causing different arrival locations in the near-surface aquifer. The important role of sorption is illustrated by the difference between the strongly sorbing radionuclide Zr-93 and the weakly sorbing I-129. Whereas Zr-93 in no case reaches the model surface within 1 million years I-129 arrives there in all climate states.

Under climate conditions, as they occur today, steady state conditions of the flow field and salt concentrations are reached after about 150,000 to 200,000 years. The dominant transport process is advection. The impact of hydraulic windows is quite strong, since they cause different transport directions of the radionuclides. In model 1 the single hydraulic window in the southern part causes transport in southern direction and radionuclide arrival at the surface in the south, whereas in model 2 with two hydraulic windows the preferred flow direction is northwards causing radionuclide arrival at the surface above the northern hydraulic window. However, all radionuclides except Zr-93 reach the surface within 1 million years.

In the warmer climate state assuming a flooding of the area with a 50 m high column of sea water diffusion processes dominate in the whole area so that more than 700,000 years are required to reach steady state salt concentrations. A steady state flow field, however, is reached after less than 50,000 years. Radionuclide transport by diffusion is comparably slow demonstrated by the fact that only weakly sorbing I-129 and the uranium isotopes (with their daughters) reach the model surface within 1 million years. Since diffusion dominates the results for model 1 and 2 are similar, i.e. the number of hydraulic windows in the aquitard is nearly of no relevance for this climate state.

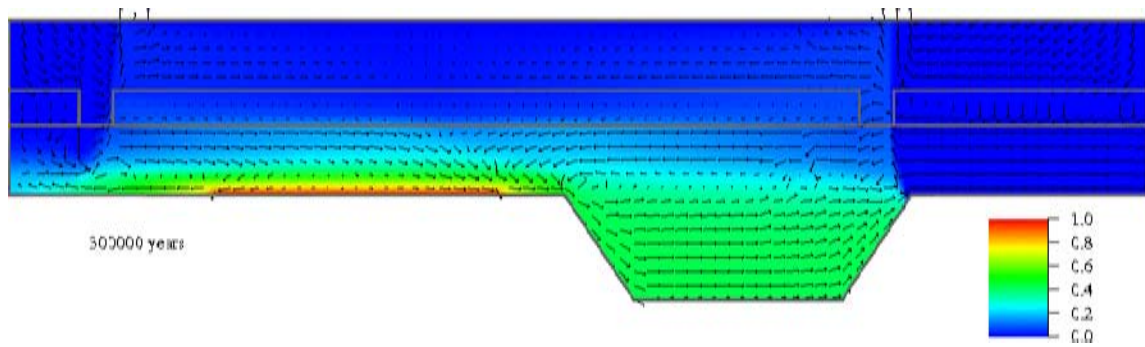

a: *Constant Climate*, 300,000 a

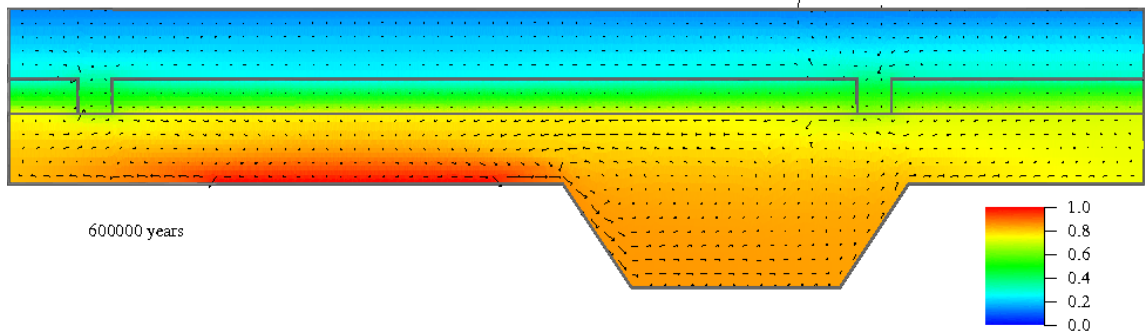

b: *Sea Water Inundation*, 600,000 a

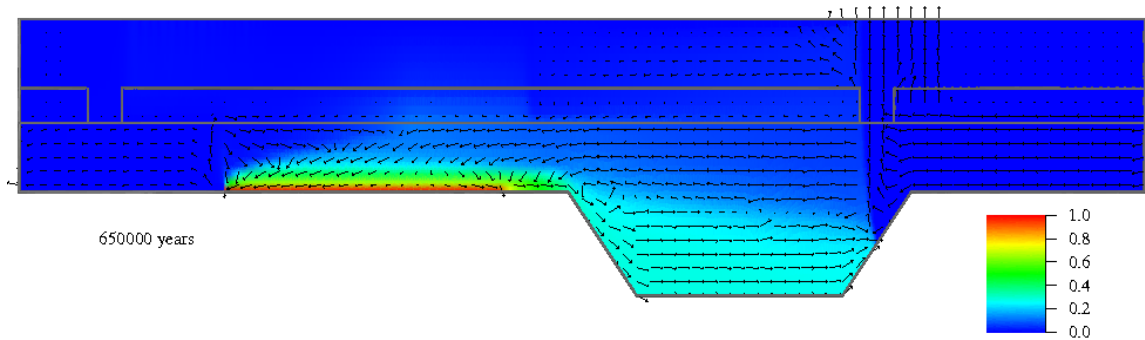

c: *Permafrost*, 650,000 a

Fig. 57 Steady-state flow fields for Constant climate conditions (a), for Sea water inundation (b) and Permafrost (c)

For the cold climate with periglacial conditions it is assumed that the permafrost extends over the entire thickness of the upper aquifer of 100 m. For permafrost zones a reduction of permeability from 10^{-12} m^2 to 10^{-20} m^2 is assumed. However, unfrozen zones, so-called taliks, may form in the upper aquifer below the river Elbe and Seege which maintain their original permeability of $1 \cdot 10^{-12} \text{ m}^2$. For the aquitard and the lower aquifer no permafrost conditions are assumed. A second characteristic of the model is a high freshwater inflow into the lower aquifer at the northern edge of the model area caused by the nearby inland ice sheets. As a result higher advection velocities in the unfrozen lower aquifer occur than in the other climate states. Under such conditions the number and the position of the hydraulic windows are also of high relevance. Together

with the extension and position of the taliks in the upper aquifer, they determine the flow velocity in the lower aquifer and the distribution of the salt concentration. For model 2 fresh water conditions occur in the aquitard and the upper aquifer. In this case Cs-135 do not reach the surface due to the increased sorption values under freshwater conditions and of course due to the reduced transport velocity in the low permeable frozen upper aquifer.

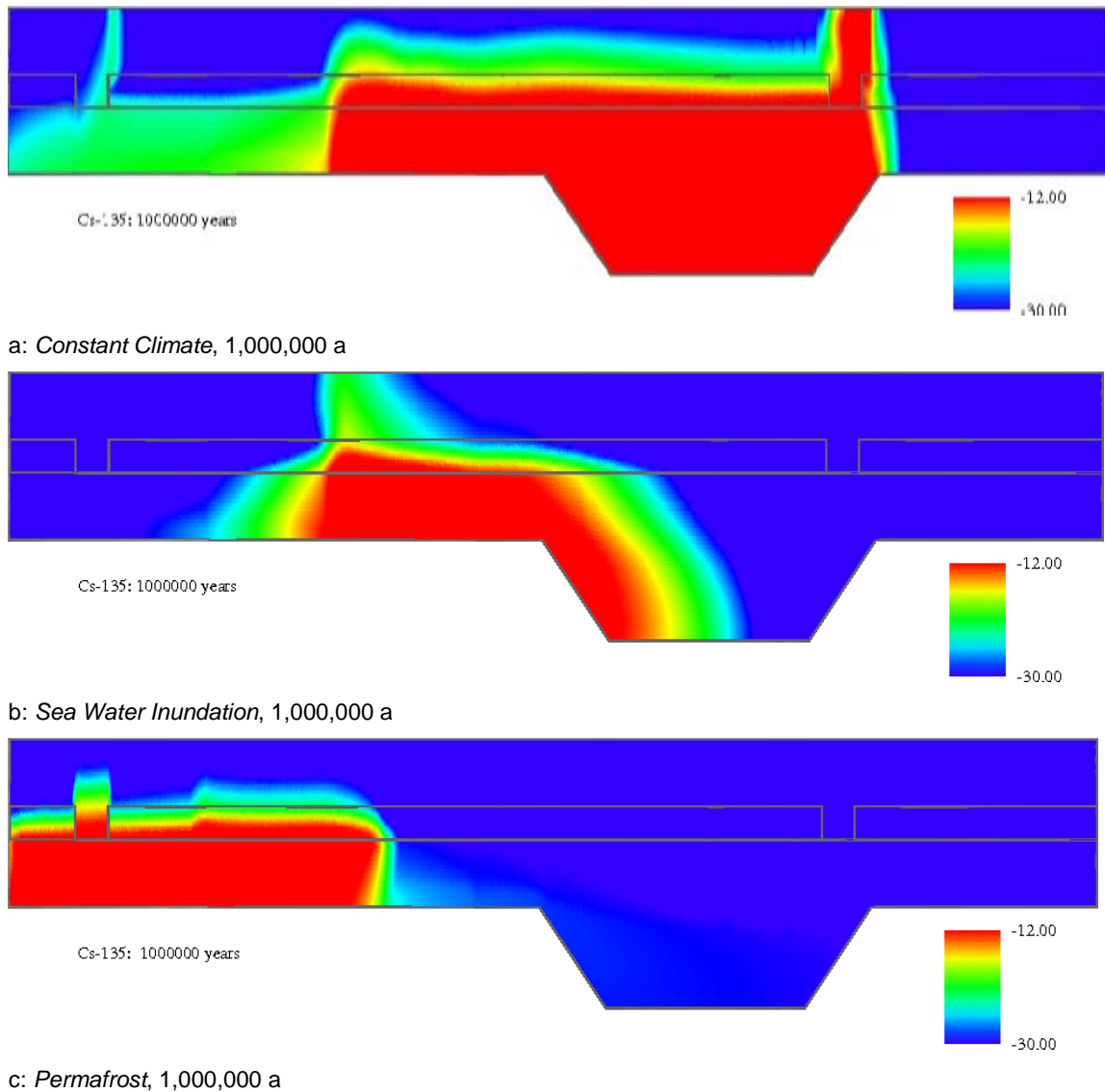

Fig. 58 Distribution of Cs-135 in the model area after 1 million years for stationary climate conditions (a), for Sea water inundation (b) and Permafrost (c)

For biosphere modelling in total six different climate states, i.e., steppe (Bs), Mediterranean (Cs), temperate (Cfb), boreal (Dfa/Dfb), and tundra (Et) have been considered, respectively. Data for temperature, precipitation, and humidity were taken

from so-called analogue sites, which are characterised by those climates today: Marrakesh, Rome, Magdeburg, Rostow, Turku and Vardo, respectively.

Two geosphere-biosphere interfaces (GBIs) have been considered:

- Radionuclides enter the biosphere via withdrawal of contaminated groundwater (“well”)
- radionuclides enter the biosphere directly (in case of a high water table) and cause contaminations of soils (“rising groundwater”)

For both GBIs, the exposure via ingestion, inhalation of resuspended contaminated soil particles and external exposure due to stay on contaminated land was taken into account. For the estimation of the ingestion dose, it was assumed that contaminated groundwater is used as drinking water for humans and cattle, irrigation water and host water for fish production.

For all climate states dose conversion factors were calculated by different biosphere models. The impact of the climate state on the biosphere modelling was considered by differences in the

- consumption habits,
- required irrigation amounts,
- considered exposition pathways and GBIs,
- parameters for radionuclide behaviour in soils (migration and transfer to the plant), for erosion and resuspension, and feeding rations for animals.

The variations among all climates for Ra-226, Th-230, Pa-231, U-238, Np-237, Am-243, and Pu-239 are relatively small, mostly the differences are less than a factor of 5 (see Fig. 59). In general, the transfer for these radionuclides through food chains is relatively low, and the mobility within the plant subsequent to foliar deposition is low as well. Therefore, the intake of radionuclides with drinking water dominates over the other ingestion pathways. This does not mean that root uptake and migration are not influenced by environmental conditions, but even under conditions that cause enhanced transfers of actinides, the transfer to man changes only slightly. For the geosphere biosphere interface there is a tendency for increased dose conversion factors with increased aridity as also shown in Fig. 59.

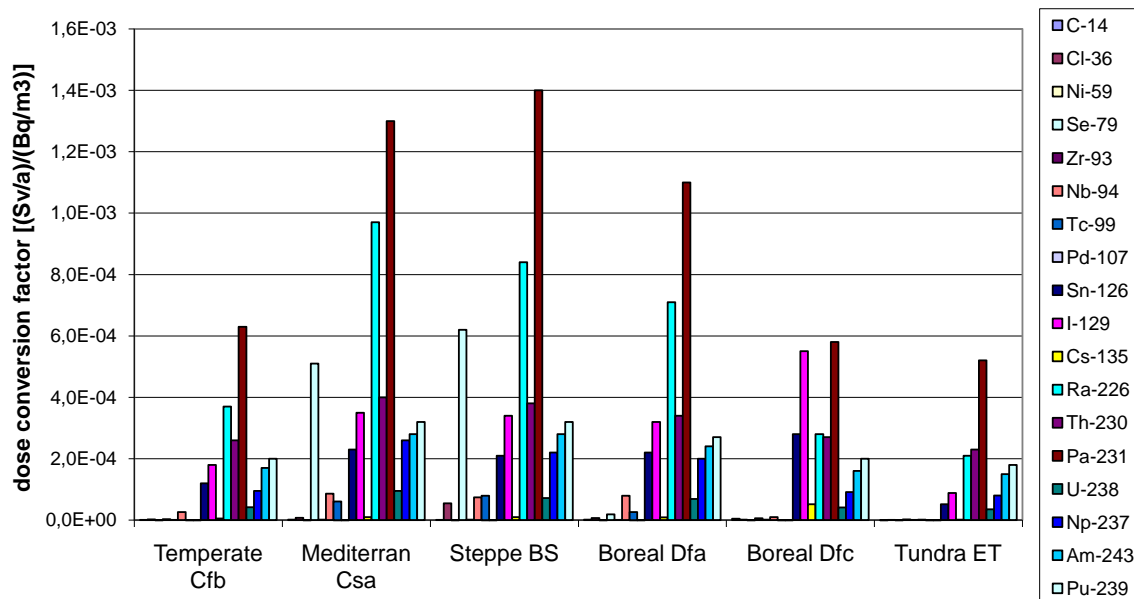

Fig. 59 Dose conversion factors of several radionuclides for different climate states (geosphere-biosphere interface: well)

The results further show that the dose conversions factors for other radionuclides vary considerably for the different climate states. This variation is strongly dependent on the different geosphere-biosphere interfaces. For the temperate and the boreal climates, the interface “well” causes higher dose conversion factors, whereas in case of the tundra climate, dose conversion factors are higher for the interface “rising groundwater”.

For the GBI “well”, the highest variations between the different climates are found for ^{14}C , ^{36}Cl , ^{94}Nb , ^{135}Cs and for the redox-sensitive radionuclides ^{79}Se , ^{99}Tc , and ^{129}I as illustrated in Fig. 60. Variations are caused especially by the following factors:

- Due to the differences in temperature, precipitation and evapotranspiration at the reference sites the irrigation rates and therewith the input of radionuclides to soil varies considerably by a factor of about 6, which has a direct impact on the exposure via ingestion of foods, inhalation and external exposure.
- The root uptake and migration of ^{79}Se , ^{99}Tc , and ^{129}I depends largely on the soil characteristics. The root uptake of selenium and technetium is enhanced on well aerated and dry soil, as it is the case for steppe climate. In this case selenate and pertechnetate are the predominating chemical species which are readily available for root uptake. At the same time, due to the aridity, the migration to deeper soil layers is reduced compared to the other climates. On the other hand for ^{129}I , root

uptake is highest in wet and water-logged soils which occur especially under cold climates.

- The intake rates for the reference climates are different. For steppe climate a daily water consumption of 3 l d^{-1} is assumed compared to 2 l d^{-1} for the other climates to account for the higher water demand under hot conditions. Furthermore, in the steppe climate, the husbandry of small ruminants as sheep and goat is relevant. The transfer of some elements to sheep and goat is much higher than to beef, which causes an increased radionuclide intake by humans. Among the radionuclides considered in this study, this is especially the case for Cs-135 and I-129.

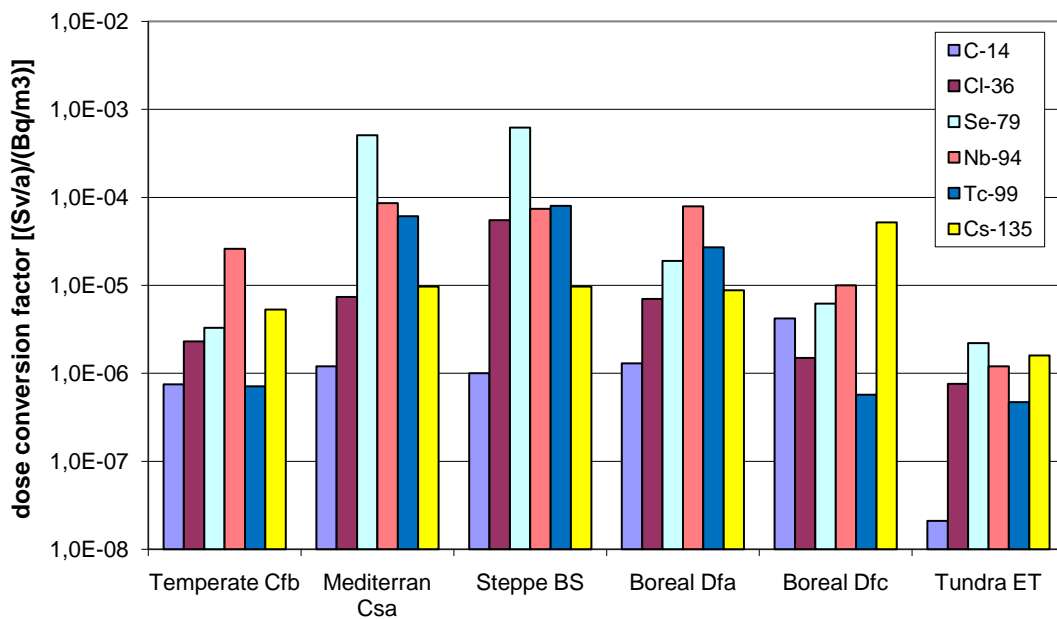

Fig. 60 GBI “well”: Dose conversion factors for selected radionuclides and different climate states

For the GBI “rising groundwater”, the steppe climate is not taken into account, since the assumption of hot climate and agriculture on areas affected by groundwater appears somewhat contradictory. For this interface, the variations among the climates are low, with the exception of the radionuclides ^{14}C , ^{129}I , and ^{135}Cs , whose dose conversion factors are by far highest for tundra climate.

- For ^{14}C , the high exposure for tundra climate is due to the high consumption of fish, which accumulates ^{14}C considerably.
- For ^{129}I , and ^{135}Cs the strong increase is caused by their different behaviour in soil. Under the conditions of tundra climate, in wet and water-logged soils, the

predominant iodine species is iodide which is readily available for root uptake. The transfer factors of cesium are also considerably enhanced for the low pH and high organic matter found in tundra climate, which causes high concentrations in grass and reindeer, berries and mushrooms.

For the interface “rising groundwater” by far highest differences in dose conversion factors for the different climate states are found for Cs-135 with nearly three orders of magnitude and for I-129 with more than two orders of magnitude. The differences for all other radionuclides are below one order of magnitude.

This first study on the implications of different future climate states on the long-term safety of a radioactive waste repository in rock salt was restricted to the processes in the overburden and the biosphere, where the highest impact is expected. It was also restricted to the consideration of single discrete climate states. However, yet it is not clear, which effects the transfer between different climate states might cause. Therefore, in a future project the investigation of transient conditions for flow and transport in the overburden as well as for the biosphere processes is planned. It is also planned to further study potential repercussions of the geosphere on the biosphere processes.

Moreover, in a later step, a complex hydrogeological model representing a more detailed description of the features at the site should be used to simulate flow and transport. It will be evaluated if additional effects and processes might play a role, if a more detailed model with additional features is applied.

4.5 New aspects of bentonite saturation – EBS Taskforce

4.5.1 Task Force on EBS

The still ongoing Task Force on Engineered Barrier Systems has the objectives

- to verify the ability to model THMC and gas migration processes in the bentonite buffer,
- to identify possible gaps in the conceptual models, and
- to refine and to improve codes (coupling and 3D-capability).

The work is divided into two tasks, Task 1 “THM processes in buffer materials (THM)” and Task 2 “Gas migration in buffer materials (Gas)”. Each task comprises two phases each of which is based on benchmark exercises. In between the codes were audited. In the first phase the codes were tested against well-controlled laboratory experiments, in the second, longer phase against field experiments. The results of the experiments were provided for each member of the Task Force together with the benchmark description, and emphasis was laid on an open discussion of problems and solutions during modelling.

4.5.1.1 THM-modelling of bentonite re-saturation

Phase 1 – lab-scale modelling

Laboratory experiments with different types of bentonite under different temperature conditions were chosen as a basis for the first phase of the benchmark exercise THM which aimed to show whether all relevant re-saturation phenomena are included in the numerical models. It turned out that heat flow modelling could be modelled satisfyingly. It was also concluded that the temperature fields were hardly affected by the varying water content.

By and large the simulated water content, too, met the measurements rather well. Generally, the agreement was better for isothermal tests than for non-isothermal tests. This was explained by the different treatment of the vapour transport and of the gas phase in different codes. However, some non-isothermal tests showed an unexpected decrease in the water uptake rate after some time in comparison to the model results. This effect was not understood. It could not be decided whether the measuring equipment had failed or a physical process was missing in the models.

Most problems were encountered calculating mechanical quantities since measurements of stress and strain are associated with relatively high uncertainties. Moreover, the mechanical material behaviour is not investigated for all possible combinations of thermal and hydraulic conditions. Only a minor influence of mechanical effects on the re-saturation behaviour was found.

Phase 2 – in-situ scale modelling

Presently only work on the first benchmark test of THM phase 2 - a long-term isothermal test and a non-isothermal test - is advanced far enough to allow some conclusions about the model performances. Modelling of heat flow stated again no problem. The hydraulic results for the buffer were satisfying but not the pore pressure in the rock. The development of the total stresses as well as the strains is not fully understood. The hydro-mechanical coupling of the models appeared not to be of major influence on the results. The experimenters concluded that already history matching of such an uptake experiment is still a challenge.

Alternative approaches

The team from POSIVA had derived THM-equations starting with thermodynamic basic equations and had used the code FreeFem++ for solving the resulting balance equations. This required only symbolic programming of the differential equations. However, while the tests of phase 1 could more or less be reproduced the attempt failed in phase 2.

Instead of modelling the bentonite-sand mixture in benchmark THM 2.1 as a homogeneous material one team of Clay Technology assumed incomplete mixing of bentonite and sand. This would lead to well-distributed but separate sand clusters in the buffer that form sinks for the water. Already a sand cluster fraction of 7% in the model strongly influenced the results.

Another team of Clay Technology had modified the equations of state for two-phase flow in such a way that liquid water flow only happened at extremely high saturations in the model. The results led to the conclusion that vapour diffusion is the dominating water transport mechanism in benchmark THM 2.1. At a later stage the team from CRIEPI confirmed the results of Clay Technology.

The alternative approach of GRS and the modelling results are described in detail in section 4.5.2. An almost identical conceptual approach was followed by the team from the University of Liberec. So far the code worked not as successful as the GRS model but it includes a heat balance equation and it has been extended to 3D in the meantime.

4.5.1.2 Modelling gas flow through fully saturated bentonite

The phenomenon of gas flow through fully saturated bentonite investigated in Task 2 “Gas” is apparently not well understood. All of the six teams that tackled this benchmark during this exercise had used THM-codes that are based on two-phase flow hydraulics. Three teams ended their work without having more than preliminary results. One team commented: “It seems that two-phase flow models are not suited to this type of problem”.

Two teams had tried to include mechanical processes like initiation of micro cracks at high gas pressures into their codes, one directly in the mechanical part of the code and one indirectly via the hydraulic equations of state. While no successful modelling was reported following the first approach, results of the second approach yielded a reasonable pressure development but also yielded water outflow that was not observed in the experiment. However, the resulting mathematical model cannot be interpreted as a classical two-phase flow.

One team did not focus on the benchmark exercise but on an insight modelling addressing the question of the role of heterogeneities (channelling) in the bentonite and whether two-phase flow parameters for this kind of problem can be determined in laboratory at all. Two-phase flow in a randomly generated permeability field was simulated and compared with measurements. Again, a feature was added that allowed widening of the pore channels at high pressures. It was possible to match the measurements but with another realisation of the permeability field the numerical results were far off.

A preliminary conclusion at the time is that gas flow through a fully saturated bentonite possibly depends on an extreme value of a quantity like pore channel diameter. This would make predictions quite difficult and rather call for formulations of uncertainties that can then be treated in an adequate manner.

4.5.2 Advancement of the vapour flow model

4.5.2.1 Verification of the vapour flow model of GRS

Based on the results of the EBS-project /KRO 04a/ a re-saturation concept had been developed during a recent project /NOS 05/ that explains re-saturation mainly by vapour flow in the pore space instead of liquid water flow. It is based on the idea that a narrow and completely water-saturated zone develops very fast at locations where bentonite comes into contact with liquid water. Here, the permeability is reduced to such an extent that the amount of liquid water that enters the bentonite balances the amount of water evaporating at the water-air interface inside the bentonite. This interface does therefore not proceed into the bentonite but instead provides a locally fixed boundary for water evaporation and subsequent vapour diffusion into the pore space. Under constant volume conditions water uptake by the clay minerals eventually comes to an end when further swelling is not possible anymore. From then on liquid water - still drawn by capillary forces - can proceed further into the bentonite again. More details of the conceptual model can be found in /KRO 04b/.

According to this conceptual model two processes are controlling re-saturation:

- water transport in the pore space due to vapour diffusion and
- hydration of water in the interlamellar space of the clay minerals.

The first process is well known but the second one required some attention. Hydration, meaning water transfer into the clay particles, is caused by a gradient in the chemical potential of the mobile vaporous water in the pore space and of the immobile hydrated water in the interlamellar space. While the chemical potential can rather easily be formulated for pore water and for hydrated water the relation between gradient and hydration rate was not known. In /KRO 04a/ the proportionality factor was assumed to be constant and estimated based on a special laboratory experiment. To verify the new approach the numerical code VAPMOD had also been developed. The comparison between measurements and model results seemed to confirm the new concept but it was not conclusive yet.

Since the proportionality factor between hydration rate and gradient of the chemical potential was the most uncertain parameter in the model it was investigated more closely in the framework of the present project. Based on several uptake experiments

with water vapour that were found in the literature a dependence of this proportionality factor on the water content could be recognised. An analytical formulation for this factor derived from the findings improved the model results but the fit between measurements and model results remained still too far off for verifying purposes /KRO 06/.

Parallel to that, the results of generic models used in the ARTE-project /BEC 03a/ were revisited and it was concluded that the process of hydration is fast in comparison to the diffusive transport of vapour in the pore space. Dropping the assumption of hydration dynamics in favour of an instantaneous hydration, i.e. assuming instantaneous equilibrium between relative humidity in the pore space and water content of the clay particles, it was shown that the balance equation for water in the bentonite can formally be transformed into the well known empirical “diffusion law” /KRO 05/. This “law” describes the isothermal re-saturation very well with respect to the water uptake rate and the transient water content distribution in the bentonite. The coefficients from the original balance equation forming the analogue to the “diffusion coefficient” in the empirical relation were thereby identified. For the uptake experiment performed during the EBS-project the “diffusion coefficient” was directly calculated and compared to the “diffusion coefficient” derived from a fitting procedure. It was found that the two values differed only by a factor of 2.7. Both lay within the rather narrow margins that were found for the empirical “diffusion coefficient” /KRO 05/.

Having demonstrated the viability of the vapour diffusion model under laboratory conditions it still had to be verified at repository conditions i.e. at an increased hydraulic pressure and a variable temperature. Since changes in the uptake behaviour should be as clearly related to the altered uptake conditions as possible it was decided to increase the complexity of the investigated problems step by step in the following sequence:

- uptake under increased hydraulic pressure, but constant temperature, then
- uptake under increased or varying temperature but atmospheric pressure and then
- uptake under increased hydraulic pressure and varying temperature.

The Task Force on EBS formed an excellent basis for this task providing detailed descriptions of several appropriate uptake experiments in the laboratory and in-situ as well as possible discussions with the experimenters. It turned out that a set of tests from CIEMAT was best suited for this purpose, an isothermal test with water

pressurised up to 1.2 MPa and a similar non-isothermal test which was divided into two phases /VIL 05/. The first phase comprised only heating of bentonite in a closed system thus yielding exclusively temperature-induced moisture redistribution. In the second phase pressurised water was injected, too, thereby adding the process of water uptake under a temperature gradient. A principal sketch of the non-isothermal CIEMAT test is given in Fig. 61. The isothermal test looked the same except for the heater.

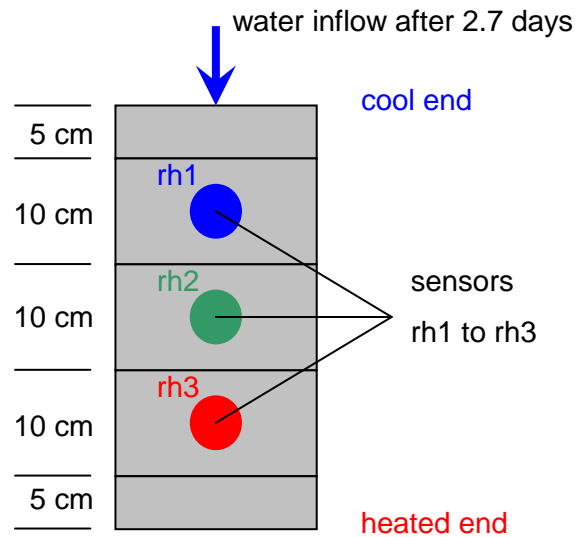

Fig. 61 Principal sketch of the non-isothermal CIEMAT test; from /KRO 08/.

In all cases the measurements could be reproduced reasonably well by the vapour flow model after certain adjustments. For the isothermal, pressurised test it was necessary to adjust the position of the inflow boundary, i.e. the water-air interface. Postulating that the pressure gradient in the narrow wetted zone between water inflow and water-air interface remains constant after increasing the hydraulic pressure the position could successfully be estimated /KRO 06/. Lack of this knowledge explains why the classical “diffusion law” approach had to fail in case of increased hydraulic pressure.

Beside these considerations, a realistic adsorption isotherm for calcium bentonite was used instead of the previously used linear ad hoc relation between relative humidity and water content. It appeared that the model results were quite sensitive to the formulation of the adsorption isotherm.

For non-isothermal modelling the mass balance equation for water in the bentonite had to be revised because temperature entered the equation as a second primary variable.

Several parameters in this equation including the adsorption isotherm are directly or indirectly temperature dependent and thus required appropriate mathematical formulations. New terms appeared in the balance equation, and the relation between the secondary variables became quite complex as shown in Fig. 62.

For these reasons the non-isothermal code VIPER (**V**apour transport **I**n **P**artially saturated bentonite as **E**ngineered barrier for **R**epositories) was written replacing the isothermal code VAPMOD. In the present version only the mass balance equation is solved. Temperature data has to be provided by external files so that heat flow is coupled to the hydraulics but not vice versa.

Additionally realised in VIPER is the idea that re-saturation stops when further hydration and thus further swelling is not possible anymore for geometrical reasons. Vapour transport in the pore space becomes very fast in this situation because it is not slowed down by hydration anymore. In the benchmark test such conditions evolved at the inflow boundary first. Where swelling was not possible anymore, the vapour partial density was kept at that value that was prescribed at the inflow boundary of the model. Physically, this assumption means that the water-air interface does not move and the non-shrinking pore space is very quickly filled with vapour. With these enhancements of the original conceptual model even the most complex physical problem of non-isothermal uptake of pressurised water could be reproduced /KRO 08/ as shown in Fig. 63.

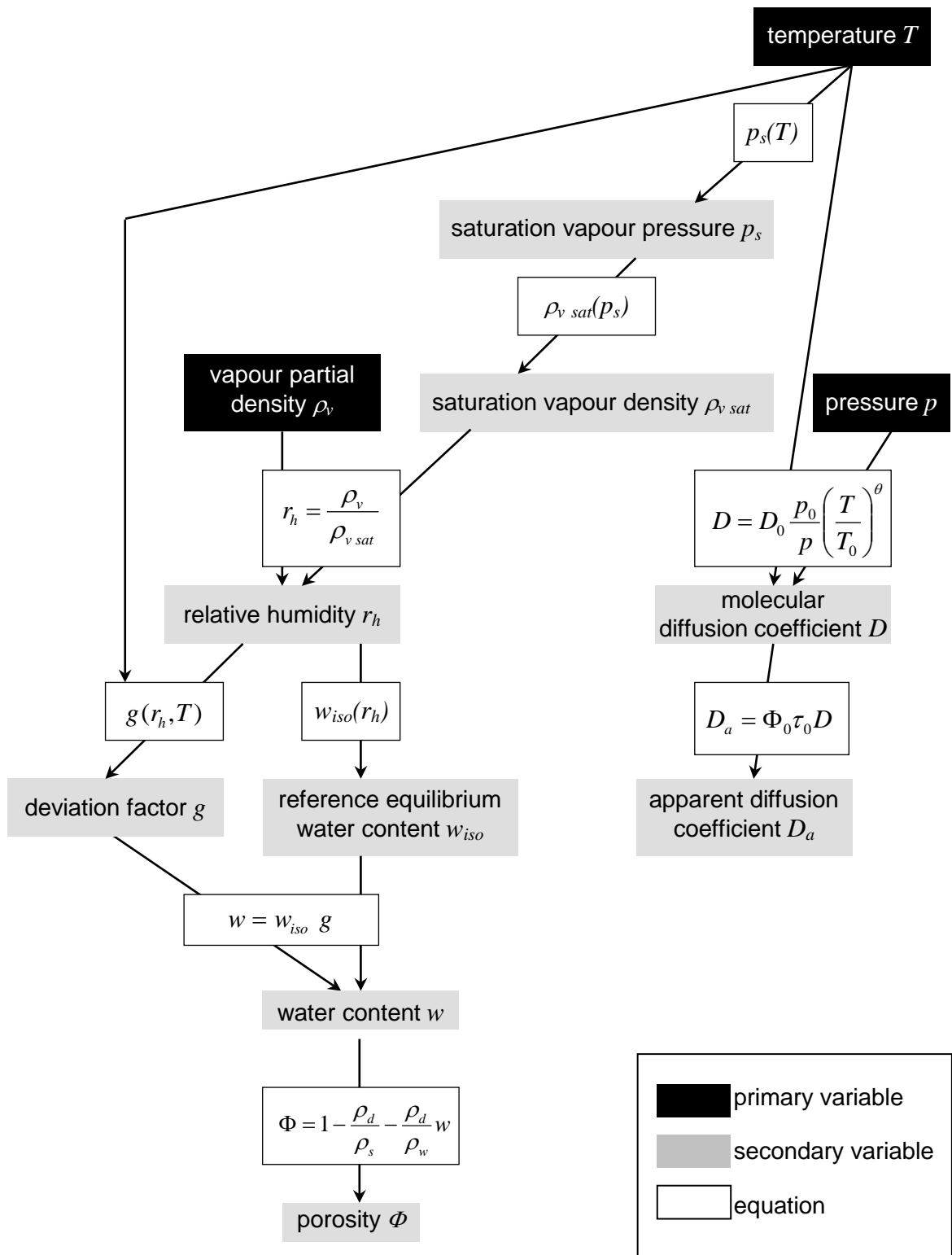

Fig. 62 Relation of primary and secondary variables in the non-isothermal vapour flow model; from /KRO 08/.

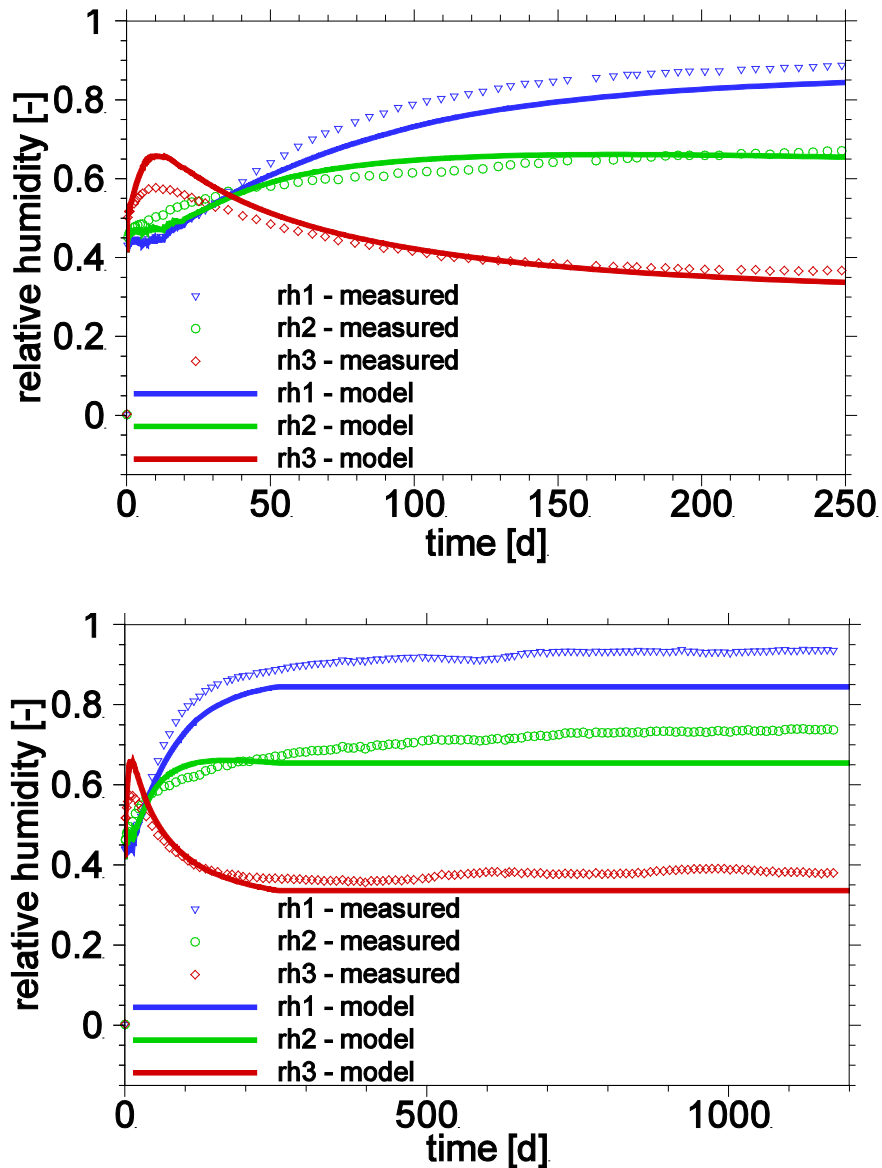

Fig. 63 Measured and calculated relative humidity data for phase 2 – water uptake; close-up (top) and full data set (bottom); from /KRO 08/.

4.5.2.2 Steady-state conditions

Modelling non-isothermal test cases with code VIPER raised the question of the final conditions at steady-state. In the present version of VIPER the postulated final re-saturation phase in which the water-air interface begins to proceed into the bentonite again is not realised. Full water saturation can therefore not be reached in a situation where water is entering the bentonite opposite to the heat source, and where a steady-state temperature gradient prevails as in the investigated test cases. The following consideration explains the reason: since vapour diffusion is the only transport

mechanism for water in the bentonite steady-state means that the vapour partial density must be constant. But saturation vapour pressure corresponds to the local temperature. The prevailing temperature gradient leads thus to a varying relative humidity and via the adsorption isotherm also to a varying water content that decreases with increasing temperature.

According to these assumptions water saturation would increase with the distance to the heater if the test reaches steady-state. This had been observed in the CIEMAT test cases as well as in the FEBEX Mock-up test /SAN 06/. However, in laboratory tests of CEA /GAT 05/ the sensor data indicated that full saturation would eventually have been reached if the tests had been run long enough. In case of the Canister Retrieval Test of SKB full saturation had actually been reached in the bentonite block at mid-height of the vertical heater /BÖR 07/. Note, that all experiments except the FEBEX Mock-up test were used as test cases in the Task Force on EBS. No consensus could be reached among the members of the Task Force about the question which of the two different types of result would represent steady-state conditions best.

The latest modelling attempt using code VIPER for simulating buffer re-saturation at mid-height of the Canister Retrieval Test seemed to confirm the assumption of a final re-saturation phase which is not yet realised in the code and involves liquid water flow commencing at a late stage of re-saturation. For a considerable time the sensor data for the relative humidity could be reproduced quite well. This includes the humidity peak after 40 days close to the heater. The peak is apparently the result of an accidental flooding of the inner gap between heater and the bentonite rings which had been described in /BÖR 07/. But then, as Fig. 64 shows, the calculated values for the sensors closer to the heater increasingly deviated from the measurements while the sensor data close to the water inflow boundary still looked good.

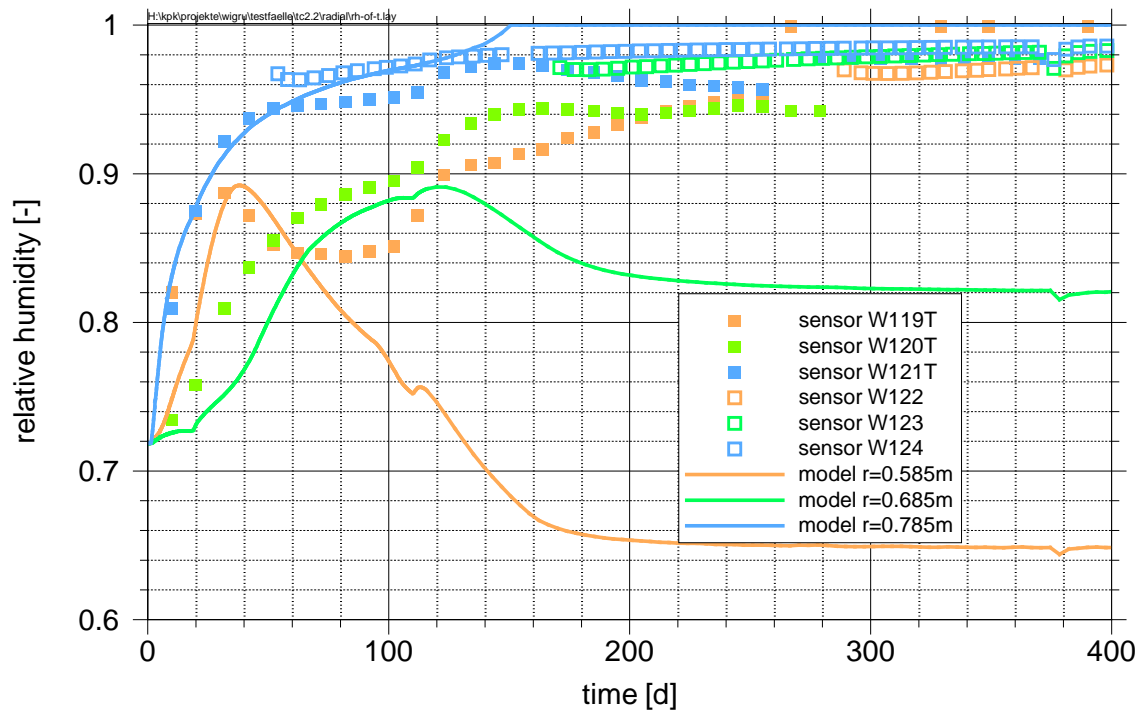

Fig. 64 Measurements and model results for the Canister Retrieval Test; axial distance r in the legend indicates distance to symmetry axis.

A consistent explanation could be a moving water front that pushes a preceding zone of high humidity into the bentonite after a certain time. This idea is backed by the fact that the initial water content of the bentonite rings of 17 % was comparatively high so that the experiment started already at an advanced state of re-saturation.

4.5.2.3 Possible further investigations

Further work appears to be advisable with respect to the problem of steady-state conditions after re-saturation under a thermal gradient, firstly, to get conclusive evidence about steady-state conditions, and, secondly, to adapt the conceptual model accordingly. Coincidentally, in 2007 at a workshop in Lund questions aiming in the same direction were raised with a view to re-saturation and long-term evolution of bentonite:

- What are the final equilibrium properties of the bentonite?
- Can we reach equilibrium?
- How do we know that we have reached equilibrium?

The conclusions referring to these questions were that, if it is not possible to reach equilibrium, a deep understanding of the relevant processes is necessary to make credible predictions.

Until now the vapour flow model has been tested against experiments on laboratory scale. To increase confidence in the model an in-situ test should be modelled as well. A promising start in this direction was the work for the Canister Retrieval Test.

In order to model the axis-symmetrical problem from the Canister Retrieval Test the one-dimensional formulation was expanded to include a varying cross-sectional area of the elements. However, in the long run an option for 2D-modelling will be necessary.

The applicability of code VIPER could be enhanced to re-saturation problems with bentonite-sand mixtures if the underlying adsorption isotherm is adapted accordingly. A referring modelling exercise could be based on the detailed documented test case THM 2.1, two in-situ tests of AECL in the Canadian URL.

Obviously no coupling of a mechanical model to code VIPER is required if the hydraulics can correctly be calculated with the TH-vapour diffusion model. In reverse this means that mechanical quantities like swelling pressure could directly be calculated from the results of VIPER using the already existing mechanical models from a common THM-code. This would further increase the field of possible applications for code VIPER and at the same time lower the required computational time for such a problem considerably.

5 Summary

The project contributed to increase the scientific knowledge for the long-term safety assessment and the safety case of a repository for radioactive wastes. Current national and international developments have been followed, r&d projects with relevance for the long-term safety analysis have been evaluated and, if possible, conceptual models to be used in long-term safety assessment have been derived.

One part of the project consisted of the documentation of the international status of the safety case. By evaluation of international guidelines and several recent, more advanced safety cases from other countries, the elements and components of the safety case for a HLW repository have been compiled and illustrated by several examples. Based on this, in a first step elements and components for the implementation of a German HLW repository in rock salt have been composed and briefly discussed. This work will be continued in the r&d project ISIBEL.

One important aspect of the safety case is that the robustness of the long-term safety assessment is strengthened by the use of multiple lines of evidence leading to complementary also qualitative safety arguments that can compensate for shortcomings in any single argument. In particular those arguments, which underpin the understanding of the key properties of the repository system, have been discussed. For the repository in rock salt a key property is the plastic behaviour of rock salt and the accompanying convergence, which leads to the closure of voids and other potential flow pathways for fluids in the normal evolution. Accordingly, arguments contributing to a deeper understanding of these key properties have to be used in the safety case. Several observations from natural systems or technical analogues are available and have been compiled.

The application of analogues to the safety case is to some extent dependent on the time scale they cover. Analogues for short-term processes, i.e. industrial analogues, have the advantage that the uncertainty of the initial conditions are relatively low and changes of the boundary conditions are of minor importance. Therefore, they can contribute to the understanding of short-term processes and especially to the confirmation of parameters and testing of models as it was exemplary shown for the healing process of the EDZ in rock salt. Arguments supporting the integrity of geological formations can only be derived from geological analogues. Such analogues

are of special importance for the German approach, since it is the philosophy that the geological barrier should play the most important role for the isolation of the waste. Especially for a potential HLW-repository in rock salt the long-term confinement of the waste in the host rock is the central part of the safety case. Analogue studies like profiles of content and isotope signatures of gases in fluid inclusions in not tectonically stressed salt formations showing that even gases have not migrated after formation of the layers or analyses of cap rock layers of salt domes indicating very low impact of subsidence even in time frames of 1 Million years strongly contribute to the multiple lines of evidence in a safety case underpinning the strength of geological disposal.

One other type of evidence and arguments in support of a safety case is the use of safety indicators complementary to dose and risk. These kinds of indicators together with performance indicators might be used to increase the robustness of results from consequence calculations (in case of salt for altered evolution scenarios). First experiences for the application of both kinds of indicators for repositories in rock salt and clay formations have been derived.

The feasibility of the three safety indicators “individual dose rate”, “radiotoxicity concentration in the biosphere water” and “radiotoxicity flux from the geosphere (overlying rock)” has been investigated. Due to the independently derived corresponding reference values the three safety indicators provide three different safety statements. The combination of the three indicators can give a stronger argument for the safety of a repository system, since the distinctive uncertainties of every single indicator are thus less important for the overall safety assessment. They have been successfully applied to both formations.

Performance indicators aim at providing a measure of the level of quality, reliability or effectiveness of a given compartment of the whole system, which cannot be done by safety indicators due to their global character. For both formations the three performance indicators “radiotoxicity inventory” in, radiotoxicity flux” and “integrated radiotoxicity flux” between defined compartments have been applied. The results show that in general the radiotoxicity inventories in the selected compartments and the corresponding fluxes between these compartments are good indicators for the evolution of the contaminant transport through the repository system. However, the inventories and fluxes inside the repository need a lot of interpretation and explanation and require a good knowledge about the repository system. The most illustrative performance indicator is the integrated radiotoxicity flux from different compartments. If

this indicator is compared with the initially emplaced radiotoxicity inventory, the performance of each compartment can be demonstrated in an illustrative way.

The proposed indicators fulfil the goal of providing a measure of the level of quality, reliability and effectiveness of a certain compartment in the presented repository system. Dependent on the lay-out of the repository system it might be necessary to introduce further indicators and add them to the proposed set. Further testing and developments concerning the use of safety and performance indicators for repositories in salt and clay are currently performed in the European project PAMINA.

Another important methodological aspect of the safety case is the definition and selection of scenarios. One special group of scenarios comprise the human intrusion scenarios. On the international level, human intrusion scenarios are considered in the safety assessment for deep geological repositories albeit not in a consistent manner. In some countries selected human intrusion scenarios are considered in the safety analysis, equivalent to other possible future evolutions. In other countries, human intrusion scenarios are considered in the safety case but separated from the other evolution scenarios. Also, various human intrusion scenarios are considered in the different nations, which differ significantly with respect to type and point in time of the initiating event, the exposition type and exposition pathway, the estimated probabilities of occurrence, the assessment of the consequences, and the group of affected persons. Here, the treatment of human intrusion scenarios in various recent national long-term safety studies considering different host-rock formations, have been compiled and illustrated.

Further progress has been achieved in the how to treat human intrusion scenarios in a German post-closure safety case. The German working group adopts the position that such a prediction is not possible. It follows, that future human intrusion cannot be treated within a systematic scenario development process. Therefore, human intrusion must be treated separately. Selected scenarios shall be used in order to assess measures which aim at reducing consequences from human intrusion. The working group recommended to confine the spectrum of human intrusion scenarios, for example, for salt as host rock to the sinking of an exploratory drilling, the construction of a mine and the preparation of a cavern. Finally the working group recommended that the regulator should establish the boundary conditions for the development of such scenarios.

A tool for radionuclide transport in clay formations to be used in long-term safety analysis does exist in Germany. Here, specific additional aspects with relevance for long-term behaviour of repositories in clay formations have been evaluated. On the one hand information about gas production and gas transport processes in clay formations have been compiled and their experimental evidences from current laboratory and in-situ studies have been discussed. Models that can be used for gas transport calculations currently only exist for the diffusion/advection and the two-phase flow. For the dilatancy controlled flow currently models for two phase flow or Darcy flow are applied, which both are strictly speaking not valid. With respect to this mechanism a number of investigations in the underground research laboratories at Bure and Mont Terri are still performed and more realistic models might be available in the near future.

On the other hand available information on the formation mechanisms of excavation damaged and disturbed zones in claystone, their properties with relevance to performance assessment and their sealing behaviour over time was compiled and evaluated. Results from investigations at Bure, Mont Terri and Tournemire have been used. The values for permeability, porosity and extension of the EDZ and their changes are available. These data together with models applied in the performance assessment studies for radioactive waste repositories in Callovo Oxfordian and Opalinus Clay form the basis for development of a conceptual model for a potential German repository in a claystone formation. However, it became clear, that in particular for the cretaceous clay formations in Northern Germany analysis of the characteristics of the excavation damaged and disturbed zone including its sealing behaviour is necessary to develop appropriate models.

Further results are also available for modelling the re-saturation of bentonite with the transport code VIPER. The aim of the work was focussed on the application to conditions with increased pressure at the water boundary and/or to non-isothermal conditions or such with increased temperature. Several suitable laboratory and in-situ uptake experiments to test the code became available in the EBS task force. In particular to describe water uptake under non-isothermal conditions further enhancements of the model were necessary. In general, the measurements could be reproduced reasonably well with the modified model.

One other part of the project dealt with the impact of specific geochemical processes on the long-term safety of the repository. Geochemical calculations have been performed to quantify the uncertainties of maximum radionuclide concentrations in

emplacement areas in the case of brine intrusion. These uncertainties might be due to uncertainties in the brine composition, redox conditions, and to uncertainties in the thermodynamic data itself. Beside this the impact of improved source terms for vitrified HLW and spent fuel was evaluated. In general the

In order to investigate the potential impact of the chemical form of C-14 in consequence calculations for repositories with spent fuel in waste in clay and salt rock, simulations with different conceptual models with respect to the retention of C-14 have been performed. Due to the fact that not enough data are available to describe the sorption behaviour of small organic molecules in the repository system organic C-14 was considered to be very mobile (as done in current safety analyses from other countries). The results show that C-14 becomes one of the most important radionuclides, when considered in organic form. For repositories in clay and rock salt even a low K_d -value would lead to a strong reduction, due to decay of a significant amount of C-14 during transport. This is due to the relatively short half life of C-14, which is in the order of typical travel times of ideal tracers through the host formation or the overburden. Therefore, sorption experiments with such molecules on relevant sorbents in the repository system would contribute to reduce conservatism.

The impact of future climate changes on the long-term safety of a radioactive waste repository in rock salt was investigated with respect to processes in the overburden and the biosphere, where highest impact is expected. All available paleo-information for a reference site in Northern Germany as well as relevant results from climate model calculations have been compiled and evaluated with regard to potential future environmental changes caused by different climates. Potential discrete climate states were selected and their impact on the conditions at the reference site described. Conceptual models for flow and transport as well as for biosphere processes have been developed implemented in numerical models and applied to the different climate states. The results show that changes in flow velocities and directions, sorption properties and enrichment processes in the soils might cause strongly different travel times, contamination locations, radionuclide concentrations in the near-surface aquifer and finally radiation exposures. However, so far simplified models and only discrete climate estates have been considered. As one important task for further investigations the study of transient conditions for flow and transport in the overburden as well as for the biosphere was identified in order to evaluate, if those transitions might cause increased releases and therewith elevated radiation exposures.

6 References

- /ALH 03/ Alheid, H.-J.: Lessons learned in Indurated Clays. In: Impact of the excavation damaged zone (EDZ) on the performance of radioactive waste geological repositories. Proceedings of the Cluster conference and workshop in Luxemburg, European Commission, 2003.
- /ALT 04/ Altmaier. M.; Brendler. V.; Bosbach. D.; Kienzler. B.; Marquardt. C.; Neck. V.; Richter. A.: Sichtung. Zusammenstellung und Bewertung von Daten zur geochemischen Modellierung. Report for the project "Sicherheitstechnische Einzelfragen: Geochemische Prozesse bei der Ausbreitung von Schadstoffen aus einem Endlager für radioaktive Abfälle". FZK-INE 002/04 (2004).
- /AND 05a/ ANDRA: Dossier 2005 Argile, Tome, Évolution phénoménologique du stockage géologique, 2005.
- /AND 05b/ ANDRA: Dossier Argile, Synthèse, Évaluation de la faisabilité du stockage géologique en formation argileuse, 2005.
- /ARB 08/ Arbeitskreis Szenarienentwicklung: Position des Arbeitskreises "Szenarienentwicklung" zur Thematik: Behandlung des menschlichen Eindringens in ein Endlager für radioaktive Abfälle in tiefen geologischen Formationen. atw **53**, 538-541, August/September 2008.
- /ARM 06/ Armand, G.: KEY Experiment. LSMHM Workshop, Bure, June 20-22th 2006.
- /BAL 08/ Baltès, B., Becker, A., Kindt, A. & Röhlig, K.-J.: Focus on Isolation and Confinement rather than on Potential Hazard: An Approach to Regulatory Compliance for the Post-Closure Phase. – in "Safety Cases for Deep Geological Disposal of Radioactive Waste: Where Do We Stand?", Symp. Proceedings, Paris, France, 23-25 January 2007, p. 295-302, OECD-NEA, 2008.

- /BAU 04/ Bauer, C.; Pépin, G.; Lebon P.: EDZ in the performance assessment of the Meuse/Haute-Marne site: Conceptual Model used and Questions addressed to the Research Program. In Proceedings of the European Commission CLUSTER EDZ Conference and Workshop on Impact of the Excavation Disturbed or Damaged Zone (EDZ) on the Performance of Radioactive Waste Geological Repositories, Luxembourg, 3 - 5 November 2003, European Commission Report EUR 21028 EN, 2004.
- /BEC 03a/ Becker, D.-A.; Buhmann, D.; Keesmann, S.; Kröhn, K.-P.; Rübél, A.: Untersuchung von Einzelthemen bezüglich der Modellierung von Endlagersystemen. GRS-200, Gesellschaft für Anlagen- und Reaktorsicherheit (GRS) mbH, Braunschweig, 2003.
- /BEC 03b/ Becker, D.-A.; Buhmann, D.; Storck, R.; Alonso, J.; Cormenzana, J.-L.; Hugli, M.; van Gemert, F.; O'Sullivan, P.; Laciok, A.; Marivoet, J.; Sillen, X.; Nordman, H.; Vieno, T.; Niemeyer, M.: Testing of Safety and Performance Indicators (SPIN), EUR 19965 EN, European Commission, Brussels 2003.
- /BEP 03/ Berest, P.; Blümling, P.: Working Group Report: EDZ in Indurated Clays. In: Impact of the excavation damaged zone (EDZ) on the performance of radioactive waste geological repositories. Proceedings of the Cluster conference and workshop in Luxemburg, European Commission, 2003.
- /BEF 06/ Bernier, F.; Li, X.L.; Bastiaens, W.; Ortiz, L.; Van Geet, M.; Wouters, L.; Frieg, B.; Blümling, P.; Desrues, J.; Viaggiani, G.; Coll, C.; Chanchole, S.; De Greef, V.; Hamza, R.; Malinsky, L.; Vervoort, A.; Vanbrabant, Y.; Debecker, B.; Verstraelen, J.; Govaerts, A.; Wevers, M.; Labiouse, V.; Escoffier, S.; Mathier, J.-F.; Gastaldo, L.; Bühler, Ch.: Fractures and Self-Healing within the Excavation Disturbed Zone in Clays. EU-report 22585, 2006.
- /BLÜ 05/ Blümling, P.; Bernier, F.; Lebon, P.; Martin, C.D.: The excavation damaged zone in clay formations – time-dependent behaviour and influence on performance assessment. In: Clays in Natural & Engineered Barriers for Radioactive Waste Confinement, 2nd International Meeting (Tour), Abstracts, ANDRA, 2005.

- /BFS 05/ Konzeptionelle und sicherheitstechnische Fragen der Endlagerung radioaktiver Abfälle. Wirtsgesteine im Vergleich. Synthesebericht des Bundesamts für Strahlenschutz. Salzgitter, 2005.
- /BLÜ 03/ Blümling, P.; Konietzky, H.: Development of an excavation damaged zone in claystone (Opalinus Clay). Geotechnical Measurements and Modelling, Natau, Fecker & Pimental (eds.), Swets & Zeitlinger, Lisse, 2003.
- /BOI 05/ Boisson, J.-Y.: Clay Club Catalogue of Characteristics of Argillaceous Rocks. NEA No. 4436, Radioactive Waste Management ISBN 92-64-01067-X, OECD 2005.
- /BOR 86/ Bornemann O.; Fischbeck R.: Ablaugung und Hutgesteinsbildung am Salzstock Gorleben. Z. dt. Geol. Ges. 137, 71-83, 1986.
- /BOS 02/ Bossart, P.; Meier, P.M.; Moeri, A.; Trick, Th.; Mayor, J.-C.: Geological and hydraulic characterisation of the excavation disturbed zone in the Opalinus Clay of the Mont Terri Rock Laboratory. Engineering Geology 66, 19-38, 2002.
- /BÖR 07/ Börgesson, L.: Canister Retrieval Test. Compilation made for the EBS Task Force, 2007.
- /BUH 08a/ Buhmann, D.; Mönig, J.; Wolf, J.; Heusermann, S.; Keller, S.; Weber, J. R.; Bollingerfehr, W.; Filbert, W.; Kreienmeyer, M.; Krone, J.; Tholen, M.: Überprüfung und Bewertung des Instrumentariums für eine sicherheitliche Bewertung von Endlagern für HAW – ISIBEL. Gemeinsamer Bericht von DBE TECHNOLOGY GmbH, BGR und GRS. DBE TECHNOLOGY GmbH Peine, 2008.
- /BUH 08b/ Buhmann, D.; Mönig, J.; Wolf, J.: Untersuchung und Ermittlung von Freisetzungsszenarien – Teilbericht zum Projekt ISIBEL: "Überprüfung und Bewertung des Instrumentariums für eine sicherheitliche Bewertung von Endlagern für HAW". Gesellschaft für Anlagen- und Reaktorsicherheit (GRS) mbH, GRS-233, Braunschweig 2008.

- /COL 05/ Colenco: Untersuchungen der menschlichen Einwirkungen auf ein Endlager für radioaktive Abfälle und der damit verbundenen Auswirkungen auf die Führung des Nachweises der Langzeitsicherheit. Colenco Bericht 3184/11, 2005.
- /CRU 06/ Cruchaudet, M.: Callovo-Oxfordian hydrogeology. LSMHM Workshop, Bure, June 20-22th 2006.
- /DEN 97/ Deng, B.; Campbell, T.J.; Burris, D.R.: Hydrocarbon Formation in Metallic Iron/Water Systems. *Environ. Sci. Technol.* 31, 1185-1190 (1997).
- /DUV 03/ Duveau, G.; Chen, W.Z.; Shao, J.F.; Ozanam, O.: Numerical Modelling of EDZ in Unsaturated Argillite: Influence of Constitutive Laws and Hydromechanical Parameters In: Impact of the excavation damaged zone (EDZ) on the performance of radioactive waste geological repositories. Proceedings of the Cluster conference and workshop in Luxemburg, European Commission, 2003.
- /ERI 90/ Eriksson, G. und Hack, K.: ChemSage - A Computer Program for the Calculation of Complex Chemical Equilibria. *Metallurgical Transactions B.* (21B). 1013 (1990).
- /GAT 05/ Gatabin, C.; Billaud, P.: Bentonite THM mock-up experiments, sensors data report. Report Réf. NT DPC/SCCME 05-300-A, CEA, Paris, 2005.
- /HER 07/ Herrmann, A.G.; Röthemeyer, H.: Naturbeobachtungen am Geosystem Salzstock Gorleben. Das unsichtbare sichtbar machen. *Forschung, Erkenntnis, Besinnung. atw Internationale Zeitschrift für Kernenergie*, 52, 333-341, 2007.
- /HOR 96/ Horseman, S.T.; Higgo, J.J.W.; Alexander, J.; Harrington, J.F.: Water, Gas and Solute Movement through Argillaceous Media. Report CC-96/1, NEA, 1996.
- /HSK 93/ Hauptabteilung für die Sicherheit der Kernanlagen (HSK) Schutzziele für die Endlagerung radioaktiver Abfälle. Richtlinie für schweizerische Kernanlagen HSK-R-21d. Villigen, November 1993.

- /HÄF 01/ Häfner, F.; Belohlavek, K.; Behr, A.; Förster, S.; Pohl, A.: In-situ-Ermittlung von Strömungskennwerten natürlicher Salzgesteine in Auflockerungszonen gegenüber Gas und Salzlösungen unter den gegebenen Spannungsbedingungen im Gebirge. Abschlussbericht, BMBF-Kennzeichen 02C05276, Technische Universität Freiberg, 2001.
- /HÄF 04/ Häfner, F.; Voigt, H.-D.; Behr, A.: Zeitliche Veränderung der Ausdehnung und der hydraulischen Eigenschaften von Auflockerungszonen um Hohlräume in Gesteinen mit visko-plastischen Eigenschaften. Abschlussbericht, BMBF-Kennzeichen 02C0820, Technische Universität Freiberg, 2004.
- /KIE 00/ Kienzler, B.; Schüßler, W.; Metz: Berechnung der maximalen Radionuklidkonzentration im geochemischen Milieu des Nahfeldes der Abfälle. Final report for a research project „Erstellung eines integrierten Nahfeldmodells von Gebinden hochaktiver Abfälle im Salzstock Gorleben: geochemisch fundierter Quellterm für HAW-Glas, abgebrannte Brennelemente und Zement“. Forschungszentrum Karlsruhe. FZK-INE 002/00 (2000).
- /IEA 06/ International Atomic Energy Agency: Geological Disposal of Radioactive Waste. Safety Requirements. – IAEA Safety Standards Series No. WS-R-4, Vienna, 2006.
- /IAE 03/ IAEA: Safety indicators for the safety assessment of radioactive waste disposal. Sixth report of the Working Group on Principles and Criteria for Radioactive Waste Disposal. IAEA-TECDOC-1372, Vienna, 2003.
- /IAE 94/ IAEA: Safety indicators in different time frames for the safety assessment of underground radioactive waste repositories. IAEA-TECDOC-767, Vienna 1994.
- /ISH 08/ Ishiguro, K.: Compilation of priority radionuclides from viewpoint of long-term safety assessment. Tokio 2008.
- /JAR 94/ Jaritz W.: Die Entwicklungsgeschichte des Standortes Gorleben als natürliches Langzeitverhalten eines Barrierensystems. Z. dt. Geol. Ges. 145, 192-206, 1994.

- /JOC 08a/ Jockwer, N.; Wieczorek, K.: Gas Migration In The Opalinus Clay As A Function Of The Gas Pressure. WM2008 Conference Phoenix, AZ.
- /JOC 08b/ Jockwer, N.; Wieczorek, K.: Investigations on gas generation, release, and migration in the frame of FEBEX. GRS-243, Gesellschaft für Anlagen- und Reaktorsicherheit (GRS) mbH, Braunschweig, 2008.
- /JOC 08c/ Jockwer, N.; Wieczorek, K.: Gas migration in the Opalinus Clay as a function of the gas injection pressure. GRS-XXX, Gesellschaft für Anlagen- und Reaktorsicherheit (GRS) mbH, Braunschweig, 2008.
- /JOH 04/ Johnson, L.; Schwyn, B. (eds): Proceedings of a workshop on the release and transport of C-14 in repository environments. NAGRA Interner Bericht 04-03, February 2004.
- /KRO 08/ Kröhn, K.-P.: Simulating non-isothermal water uptake of compacted bentonite without coupling of hydraulics to mechanics. Proceedings of the Workshop on "Long-term performance of smectitic clays embedding canisters with highly radioactive waste" held in Lund, 2007, Applied Clay Science (in press), 2008.
- /KRO 06/ Kröhn, K.-P.: Further Investigations confirming the dominance of vapour transport during bentonite resaturation. GRS-222, Gesellschaft für Anlagen- und Reaktorsicherheit (GRS) mbH, Braunschweig, 2006.
- /KRO 05/ Kröhn, K.-P.: New Evidence for the Dominance of Vapour Diffusion During the Re-saturation of Compacted Bentonite. Engineering Geology, Volume 82, Issue 2, 2005.
- /KRO 04a/ Kröhn, K.-P.: Modelling the re-saturation of bentonite in final repositories in crystalline rock. Abschlussbericht des BMWA-Vorhabens 02 E 9430, GRS-199, Gesellschaft für Anlagen- und Reaktorsicherheit (GRS) mbH, Braunschweig, 2004.

- /KRO 04b/ Kröhn, K.-P.: Proposal of an alternative re-saturation model for bentonite buffers - the conceptual model, the numerical model and the data base. in: Pusch, R., Svemar, Ch.: Proceedings from the TaskForce-related meeting on Buffer & Backfill modelling" in Lund. SKB International Report IPR-04-23, 2004.
- /LIE 01/ Liedtke, L.; Engelhardt, I.; Fiene, M.; Kröhn, K.-P.; Kull, H.; Jakobs, H.; Thorenz, C.: Äspö Hard Rock Laboratory – Two-phase flow in fractured crystalline rock, Investigations in Niche 2175. International Progress Report IPR-02-09, SKB, 2001.
- /LUE 99/ Lührmann, L.; Noseck, U.; Storck R.: Spent Fuel Performance Assessment (SPA) for a hypothetical repository in crystalline formations in Germany. Gesellschaft für Anlagen- und Reaktorsicherheit (GRS) mbH, GRS-154, Braunschweig 1999.
- /MAR 08/ Marschall, P.; Cuss, R.; Wieczorek, K.; Popp, T.: State of the Art on Gas Transport in the Tunnel Nearfield / EDZ. NF-PRO Deliverable D4.4.1, 2007.
- /MAR 05/ Marschall, P.; Horseman, S.; Gimmi, T.: Characterisation of Gas Transport Properties of the Opalinus Clay, a Potential Host Rock Formation for Radioactive Waste Disposal. Oil & Gas Science Technology, Vol. 60 No.1, 121-139, 2005.
- /MAR 03/ Martin, C.D.; Lanyon, G.W.; Blümling, P.; Mayor, J.C.: The Excavation Disturbed Zone around a Test Tunnel in the Opalinus Clay. In: Impact of the excavation damaged zone (EDZ) on the performance of radioactive waste geological repositories. Proceedings of the Cluster conference and workshop in Luxemburg, European Commission, 2003.
- /MAT 03/ Matsui, H.; Sugihara, K.; Sato, T.: In-situ Experiments on Excavation Disturbance in JNC's Geoscientific Research Program. In: Impact of the excavation damaged zone (EDZ) on the performance of radioactive waste geological repositories. Proceedings of the Cluster conference and workshop in Luxemburg, European Commission, 2003.

- /MAZ 03/ Mazurek, M., Pearson, F. J. and Bock, H. (2003): Features, Events and Processes Evaluation Catalogue for Argillaceous Media. NEA4437, Radioactive Waste Management ISBN 92-64-02148-5, OECD 2003.
- /MCE 03/ McEwen, T.: Review of the Conclusions of Previous EDZ Workshops. In: Impact of the excavation damaged zone (EDZ) on the performance of radioactive waste geological repositories. Proceedings of the Cluster conference and workshop in Luxemburg, European Commission, 2003.
- /MEI 02/ Meier, P.; Trick, Th.; Blümling, P.; Volckaert, G.: Self-healing of fractures within the EDZ at the Mont Terri Rock Laboratory: Results after one year of experimental work. - In "Proceedings International workshop on Geomechanics": Hoteit, N. et al. (eds): Hydromechanical and Thermohydromechanical Behaviour of Deep Argillaceous Rocks, Paris, 11-12 October 2000; Swets & Zeitlinger, (Lisse), 2002.
- /MIE 03/ Miehe, R.; Kröhn, K.-P.; Moog, H.: Hydraulische Kennwerte tonhaltiger Mineralgemische zum Verschluss von Untertagedeponien (KENTON). GRS-193, Gesellschaft für Anlagen- und Reaktorsicherheit (GRS) mbH, Braunschweig, 2003.
- [MEN 05] Mengel, K.: Herkunft und Migration mineralgebundener Gase in marinen Evaporiten. Abschlussbericht. Technische Universität Clausthal, Clausthal-Zellerfeld 2005.
- /MUE 08/ Müller-Lyda, I.; Mönig, J.; Noseck, U.: Elemente eines Safety Case zur Realisierung eines Endlagers in Deutschland. GRS-238, Gesellschaft für Anlagen- und Reaktorsicherheit (GRS) mbH, Braunschweig, 2008.
- /MUE 97/ Müller-Lyda, I. (ed.): Erzeugung und Verbleib von Gasen in einem Endlager für radioaktive Abfälle. GRS-129, Gesellschaft für Anlagen- und Reaktorsicherheit (GRS) mbH, Braunschweig, 1997.
- /NAG07/: Fundamental Processes of Radionuclide Migration: Topics and processes dealt with in the IP FUNMIG and their treatment in the Safety Case of geologic repositories for radioactive waste. NAGRA, NAB07-25, Wetingen, 2007.

- /NAG 04/ NAGRA: Effects of Post-disposal Gas Generation in a Repository for Spent Fuel, High-level Waste and Long-lived Intermediate Waste sited in Opalinus Clay. NAGRA, NTB 04-06, Wettingen, 2004.
- /NAG 03/ NAGRA: EDZ: pneumatic testing Experiment "ED-A". Poster, 2003.
http://www.mont-terri.ch/posters/ED_A.pdf.
- /NAG 02a/ NAGRA: Projekt Opalinuston - Synthese der geowissenschaftlichen Untersuchungsergebnisse. Entsorgungsnachweis für abgebrannte Brennelemente, verglaste hochaktive sowie langlebige mittelaktive Abfälle. NAGRA, NTB 02-03, Wettingen, 2002.
- /NAG 02b/ NAGRA: Projekt Opalinus Clay - The long-term safety of a repository for spent fuel, vitrified high-level waste and long-lived intermediate-level waste sited in the Opalinus Clay of the Züricher Weinland. NAGRA, NTB 02-05, Wettingen, 2002.
- /NAG 02c/ NAGRA: Project Opalinus Clay - Models, Codes and Data for Safety Assessment. NAGRA, NTB 02-06, Wettingen, 2002.
- /NEA 08a/ NEA-OECD: Safety Cases for Deep Geological Disposal of Radioactive Waste - Where Do We Stand? Nuclear Energy Agency, Symposium Proceedings Paris, France 23. - 25. January 2007.
- /NEA 08b/ NEA/OECD: International Experiences in Safety Cases: Outcomes of the NEA IINTESC Initiative. Final Report. Nuclear Energy Agency, to be published.
- /NEA 08c/ Nuclear Energy Agency: Timing of High-level Waste Disposal, NEA No. 6244, Paris 2008.
- /NEA 08d/ NEA-OECD: The Evolving Roles of Geoscience in the Safety Case: Responses to the AMIGO Questionnaire. A report of the NEA Working Group on Approaches and Methods for Integrating Geological Information in the Safety Case (AMIGO). Nuclear Energy Agency, Paris 2008.

- /NEA 07/ NEA/OECD: Linkage of Geoscientific Arguments and Evidence in Supporting the Safety Case. Second AMIGO Workshop Proceedings Toronto, Canada, 20.-22. September 2005. Nuclear Energy Agency, Paris 2007.
- /NEA 05/ NEA-OECD: NEA Sorption Project, Phase II: Interpretation of radionuclide sorption onto substrates relevant for radioactive waste disposal using thermodynamic sorption models (by J.A. Davis, M.Ochs, M. Olin, T.E: Payne, C.J. Tweed). Nuclear Energy Agency, Paris 2005.
- /NEA 04a/ NEA-OECD: Post-closure Safety Case for Geological Repositories. Nature and Purpose. Nuclear Energy Agency, Paris 2004.
- /NEA 04b/ NEA/OECD: Geological Disposal: Building Confidence Using Multiple Lines of Evidence. First AMIGO Workshop Proceedings Yverdon-les-Bains, Switzerland, 3-5 June 2003, Nuclear Energy Agency, Paris 2004.
- /NOS 08a/ Noseck U.; Müller-Lyda, I.; Steininger, W.: Overview on Natural Analogue Studies in Germany. atw 53, 342-348, 2008.
- /NOS 08b/ Noseck, U.; Fahrenholz, Ch.; Flügge, J.; Pröhl, G.; Fein, E.: Impact of climate change on far-field and biosphere processes for HLW repositories in rock salt. GRS-241, Gesellschaft für Anlagen- und Reaktorsicherheit (GRS) mbH, Braunschweig, August 2008.
- /NOS 08c/ Noseck, U.; Wolf, J.; Moog, H.; Hagemann, S.: Chemical effects in the near field of a HLW repository in rock salt. GRS-242, Gesellschaft für Anlagen- und Reaktorsicherheit (GRS) mbH, Braunschweig, November 2008.
- /NOS 07/ Noseck U.; Brewitz, W.; Müller-Lyda, I.: To what extent can natural analogues contribute to the safety case for a repository in rock salt? In: Safety Cases for the Deep Disposal of Radioactive Waste - Where do we stand? OECD/NEA. Symposium Proceedings, Paris, France 23. - 25. January 2007.

- /NOS 05/ Noseck, U.; Brewitz, B.; Becker, D.; Buhmann, D.; Fahrenholz, C.; Fein, E.; Hirsekorn, P.; Keesmann, S.; Kröhn, K.-P.; Müller-Lyda, I.; Rübel, A.; Schneider, A.; Storck, R.: Wissenschaftliche Grundlagen zum Nachweis der Langzeitsicherheit von Endlagern. GRS-204, Gesellschaft für Anlagen- und Reaktorsicherheit (GRS) mbH, Braunschweig, Juli 2005.
- /OND 01/ ONDRAF/NIRAS: SAFIR 2. Safety Assessment and Feasibility Interim Report 2. NIRON 2001-6E, Brussels, 2001.
- /ORT 97/ Ortiz, L.; Volckaert, G.; De Cannière, P.; Put, M.; Sen, A.; Horseman, S.T.; Harrington, J.F.; Impey, M.; Einchcomb, S.: MEGAS: Modelling and experiments on gas migration in repository host rocks. Final report-phase 2. Europäische Kommission, EUR 17453 EN, Brüssel, 1997.
- /POP 07/ Popp, Till; Salzer, K.: EDZ Initial phase characterization and modelling – Influence of bedding planes. Institut für Gebirgsmechanik (IFG) GmbH, NF-PRO Deliverable D4.2.15, Leipzig, 2007.
- /POT 02/ Potthoff, S.; Perau, E.: Parameteridentifikation bei Zweiphasen-Strömungen – Theorie und Numerik. Bauhaus-Universität Weimar, Schriftenreihe Geotechnik, Heft 08, Weimar, 2002.
- /REB 06/ Rebours, H.: Geological shaft and drift follow up - EDZ observation. LSMHM Workshop, Bure, June 20-22th 2006.
- /REJ 06/ Rejeb, A.; Cabrera, J.: Time-dependent evolution of excavation damaged zone in the argillaceous Tournemire site. EUROSAFE Forum 2006. "Radioactive Waste Management: Long Term Safety Requirements and Societal Expectations". Paris, 13 & 14 November 2006.
- /ROT 05/ Rothfuchs, T.; Jockwer, N.; Miehe, R.; Zhang, C.-L.: Self-sealing Barriers of Clay/Mineral Mixtures in a Clay Repository - SB Experiment in the Mont Terri Rock Laboratory. GRS-212, Gesellschaft für Anlagen- und Reaktorsicherheit (GRS) mbH, Braunschweig, 2005.

- /RSK 08/ Gemeinsame Stellungnahme der RSK und der SSK zum GRS-Bericht „Sicherheitsanforderungen an die Endlagerung hochradioaktiver Abfälle in tiefen geologischen Formationen“, approved by RSK at the 408. Meeting on 09.05.2008, approved by SSK at the 224. Meeting on 03.07.2008.
- /RUE 08/ Rübél, A.; Mönig, J. (eds.): Gase im Endlager im Salz. GRS-242, Gesellschaft für Anlagen- und Reaktorsicherheit (GRS) mbH, Braunschweig, 2007.
- /RUE 07/ Rübél, A.; Becker, D.-A.; Fein, E.: Radionuclide transport modelling to assess the safety of repositories in clays. GRS-228, Gesellschaft für Anlagen- und Reaktorsicherheit (GRS) mbH, Braunschweig, 2007.
- /RUE 04/ Rübél, A.; Noseck, U; Müller-Lyda, I.; Kröhn, K.-P.; Storck, R.: Konzeptioneller Umgang mit Gasen im Endlager. GRS-205, Gesellschaft für Anlagen- und Reaktorsicherheit (GRS) mbH, Braunschweig, 2004.
- /RUJ 07/ Rugama, Y.; Suyama, K.; Raap, B.: Activities of OECD/NEA Expert Group on Assay Data of Spent Nuclear Fuel. Proceedings of ICAPP Nice, France, May 13-18, 2007.
- /SAN 06/ Sánchez, M.; Gens, A.: FEBEX Project, Final report, Final report on thermo-hydro-mechanical modelling. Publicación técnica 05-2/2006, ENRESA, 2006.
- /SIE 01/ Siemann, M.; Ellendorf, B.: The composition of gases in fluid inclusions of late Permian (Zechstein) marine evaporites in Northern Germany. Chemical Geology, 173, S. 31 - 44, 2001.
- /SIE 07/ Siemann, M.: Herkunft und Migration mineralgebundener Gase der Zechstein 2 Schichten in Zielitz. Kali und Steindalz, 03/2007, S. 26 – 41, 2007.
- /SKB 06/ SKB: Long-term safety for KBS-3 repositories at Forsmark and Laxemar – a first evaluation, Main Report of the SR-Can project. SKB, Technical Report TR-06-09, Stockholm, 2006.

- /SKI 02/ The Swedish Nuclear Power Inspectorate: The Swedish Nuclear Power Inspectorate's Regulations concerning Safety in connection with the Disposal of Nuclear Material and Nuclear Waste. SKIFS 2002:1. Stockholm 2002.
- /SMA 95/ Smailos, E.; Gago, J.A.; Azkarate, I.; Fieh, B.: Corrosion Studies on Selected Packaging Materials for Disposal of Heat-Generating Radioactive Wastes in Rock-Salt Formations. Forschungszentrum Karlsruhe, FZKA 5587, Karlsruhe, 1995.
- /STE 96/ Steininger, W.: Natural analogues for a repository in rock salt, the German approach. In: Proceedings of the 6th EC Natural Analogue Working Group Meeting, 12.-16. September 1994, Santa Fe. EC-Nuclear Science and Technology, EUR 16761, Brussels, 1996.
- /SVE 06/ Svensson U.: The Laxemar Repository.-Modelling changes in the flow, pressure and salinity fields, due to a repository for spent nuclear fuel. SKB R-06-57, Svensk Kärnbränslehantering AB, Stockholm, 2005.
- /SVE 05/ Svensson U.: The Forsmark Repository.-Modelling changes in the flow, pressure and salinity fields, due to a repository for spent nuclear fuel. SKB R-05-57, Svensk Kärnbränslehantering AB, Stockholm, 2005.
- /SWI 01/ Swift, B.T.; Hoch, A.R.; Rodwell, W.R.: Modelling gas migration in compacted bentonite: Gambit Club phase 2 final report. Posiva OY, Posiva report 2001-02, Helsinki, 2001.
- /THE 07/ THEREDA: Entwicklung einer thermodynamischen Referenzdatenbasis. Verbundvorhaben der GRS, FZK-INE, FZD. Gefördert von BMWI, BMBF und BfS, Laufzeit: 01.07.2006 - 30.06.2009.
- /VIL 05/ Villar, M.V.; Martín, P.L.; Barcala, J.M.: "Infiltration test at isothermal conditions and under thermal gradient", Technical report CIEMAT/DMA/M2140/1/05, CIEMAT, Madrid, 2005.

- /WIE 04/ Wieczorek, K.; Schwarzianeck, P.: Untersuchung zur Auflockerungszone im Salinar(ALOHA2). GRS-198, Gesellschaft für Anlagen- und Reaktorsicherheit (GRS) mbH, Braunschweig, April 2004.
- /WIG 08/ Wissenschaftliche Grundlagen zum Nachweis der Langzeitsicherheit von Endlagern. FKZ 02 E 10548. Forschungsvorhaben der GRS gefördert von BMWi, Laufzeit: 01.08.2008 – 31.07.2012.
- /WIL 06/ Wileveau, Y.: SUG experiment at -445 m and at -490 m of depth - geological and geomechanical Survey of Galleries. LSMHM Workshop, Bure, June 20-22th 2006.
- /WIL 03/ Wileveau, Y.; Lebon, P.; Côme, B.; Konietzky, H.: In Situ Measurements and EDZ Analysis in Vertical Shaft of the Meuse/Haute-Marne Underground Research Laboratory: Application to the Kimmeridgian Marls. In: Impact of the excavation damaged zone (EDZ) on the performance of radioactive waste geological repositories. Proceedings of the Cluster conference and workshop in Luxemburg, European Commission, 2003.
- /WOL 08/ Wolf, J.; Rübél, A.; Noseck, U.; Becker, D.-A.: Safety and performance indicators for repositories in clay and salt formations. GRS-240, Gesellschaft für Anlagen- und Reaktorsicherheit (GRS) mbH, Braunschweig, August 2008.
- /ZHA 07/ Zhang, C.-L., Rothfuchs, T.; Jockwer, N.; Wieczorek, K.; Dittrich, J.; Müller, J.; Hartwig, L.; Komischke, M.: Thermal effects on the Opalinus Clay - A joint Heating experiment of ANDRA and GRS at the Mont Terri URL (HE-D Project), GRS-224, Gesellschaft für Anlagen- und Reaktorsicherheit (GRS) mbH, Braunschweig, 2007.
- /ZHA 93/ Zhang, Z.X.: Untersuchungen zum Nachweis der Langzeitsicherheit bei der Endlagerung abgebrannter Hochtemperaturreaktor-Brennelemente in untertägigen Gebirgsformationen. Forschungszentrum Jülich, JUEL-2796, 119 S., 1993.

List of Figures

Fig. 1	Correlation of safety case, safety assessments, long-term safety assessment and additional elements of the safety case.	4
Fig. 2	Normalised safety indicators for repository in rock salt. Scenario: „Failure of shaft and drift seals“; normalized safety indicator of 1: reference value	12
Fig. 3	Normalised safety indicators for the reference case for a repository in clay; normalized safety indicator of 1: reference value	13
Fig. 4	Integrated radiotoxicity flux from different compartments for all radionuclides with initially emplaced radiotoxicity inventory for the combined failure of shaft and drift seals scenario.....	16
Fig. 5	Integrated radiotoxicity flux from different compartments for all radionuclides with initially emplaced radiotoxicity inventory for the brine inclusion scenario	16
Fig. 6	Key processes for the normal evolution (top) and for a brine intrusion scenario (bottom) for a HLW-repository in rock salt. The colour of the bars indicates the importance of the process at a distinct time: grey = high; white = low	21
Fig. 7	Location of salt domes in Northern Germany and extension of ice covers during the last glacials	23
Fig. 8	Stratigraphic layers on top of the Gorleben salt dome with cap rock breccia /BOR 86/	24
Fig. 9	Permeability of an excavation disturbed zone around a lined and an open bulkhead drift constructed 1911 in the Asse mine /WIE 04/.....	26
Fig. 10	Permeability versus distance from the rim of an excavation disturbed zone around a lined and open bulkhead drift in the Asse mine /WIE 04/..	26
Fig. 11	Effective doses by using the borehole as a well for drinking water and irrigation at Forsmark site (red line) and at Laxemar site (blue line) /SKB 06/.....	32
Fig. 12	Effective doses by cuttings spread on the ground /SKB 06/.....	32
Fig. 13	Schematic representation of the ‘exploitation drilling’ scenario (AES1) and the normal evolution scenario (NES) with a pumping well.....	35

Fig. 14	Radionuclide activity concentrations (Bq/m ³) within the Lower Rupelian aquifer, the boom Clay and the adjacent Neogene aquifer /OND 01/.....	36
Fig. 15	Diffusion of dissolved gases	78
Fig. 16	Two-phase flow	80
Fig. 17	Relationship between gas entry pressure and intrinsic permeability /MAR 05/.....	82
Fig. 18	Capillary pressure versus saturation as measured for the Opalinus Clay at the Benken site /NAG 02a/.....	85
Fig. 19	Gas permeability measurements (solid lines) and modelling (dotted lines) for the Opalinus Clay at the Benken site /NAG 02a/. Pressures measured are the fluid injection pressure and injection/extraction pressures at the sample observed on guard rings.....	86
Fig. 20	Pathway creation by pore space widening	87
Fig. 21	Pathway creation by fracturing.....	88
Fig. 22	Pressure evolution (a) and gas flow rate (b) from the gas threshold test O5 performed in the Benken borehole /MAR 05/	90
Fig. 23	Gas injection test on an Opalinus Clay core sample /POP 07/.....	91
Fig. 24	Pressure trends for different pressure steps in the injection interval of one of the boreholes of the HG-C Experiment /JOC 08a/.....	92
Fig. 25	Borehole layout (upper figure) and gas inflation and gas break through in the interval perpendicular to bedding in the HG-C Experiment /JOC 08c/.....	93
Fig. 26	Transport capacity of the three gas transport mechanisms determined from scope calculations /NAG 04/.....	94
Fig. 27	Evolution of the gas pressure at the gas entry face and gas outflow rate for clay/sand mixtures of 35/50 (above) 50/50 (below) /ROT 05/.....	97
Fig. 28	Conceptual model of the EDZ at Mont Terri; from /MAR 03/.....	103
Fig. 29	Hydraulic conductivity of the EDZ, drift in Mont Terri /NAG 02a/.....	104
Fig. 30	Alternative conceptual model for the EDZ /BOS 02/.....	104
Fig. 31	Hydraulic conductivity of the EDZ, drift ED-A-experiment /NAG 03/.....	105
Fig. 32	Measurements of the hydraulic conductivity /CRU 06/.....	106

Fig. 33	Frequency of pore diameters /AND 05a/.....	107
Fig. 34	Texture and structure of the pore space in the Callovo-Oxfordian /AND 05a/.....	108
Fig. 35	Conceptual model of the EDZ at the Bure site /AND 05a/.....	109
Fig. 36	Fishbone-like failure pattern in a drilling core at bure site /REB 06/.....	109
Fig. 37	Shape of the EDZ depending on direction of excavation and stress field /AND 05a/.....	110
Fig. 38	Calculated form and extension of the EDZ, variations depending on the stress field and depth /AND 05a/.....	111
Fig. 39	Model results for the structure of the EDZ and for the fracture connectivity /AND 05a/.....	112
Fig. 40	Location of boreholes in the KEY-experiment /ARM 06/.....	112
Fig. 41	Hydraulic conductivity from the KEY-experiment /ARM 06/; data from boreholes KEY1001 through KEY1006 in red; from KEY1101 through KEY1109 in blue, cf. Fig. 40.....	113
Fig. 42	Conceptual models of the EDZ in Tournemire; for the old railway tunnel (left) and for the gallery from 2003 (right) /REJ 06/.....	114
Fig. 43	Decrease of transmissivity in the EDZ in an open drift (blue circles) and including simulated swelling pressure of a bentonite buffer (red squares) /NAG 02a/.....	117
Fig. 44	In-situ measurements of fracture sealing in the EDZ in the Opalinus clay; mechanical load (red line), hydraulic conductivity (triangles) /BEF 06/.....	118
Fig. 45	Laboratory measurements of fracture sealing in the Opalinus clay /BEF 06/.....	119
Fig. 46	Compressive strength of different claystones as a function of water content /MAR 03/.....	121
Fig. 47	Drift seal design by ANDRA, include concrete (white) and bentonite (yellow) /AND 05b/.....	122
Fig. 48	Radionuclide activity flux out of the host rock formation for the reference case /RUE 07/: C-14 assumed to exist in organic form (solid line) or in inorganic form (dashed line).....	128

Fig. 49	Scenario “Failure of shaft and drift seals“: Effective dose rate for the different forms of C-14 and impact on the total dose rate.....	129
Fig. 50	Scenario “Brine inclusions“: Effective dose rate for the different forms of C-14 and impact on the total dose rate	129
Fig. 51	Scenario “Failure of shaft and drift seals“: Effective dose rate for the different forms of C-14 in dependence of solubility limits. Solubility limits L in [mol/l], K_d -value in [m^3/kg]	131
Fig. 52	Scenario “Failure of shaft and drift seals“: Effective total dose rate and dose rate for C-14 considering its distribution on organic and inorganic fractions in the waste (s. text for explanation)	132
Fig. 53	Comparison of the existing and the new spent fuel source term for $MgCl_2$ -rich solution and minimum solubility limits	135
Fig. 54	Comparison of the different mobilisation rates for the existing and the new source term for HLW (silica saturation at $T=200^\circ C$: $5.22 \text{ mol}/m^3$) ...	136
Fig. 55	Comparison of the existing and the new source term for vitrified HLW with regard to the effective dose rate (Mg-rich brine, maximum solubility limits)	137
Fig. 56	Impact of radionuclides on the effective dose rate for the existing and the new HLW source term ($MgCl_2$ -rich brine and maximum solubility limits).	138
Fig. 57	Steady-state flow fields for Constant climate conditions (a), for Sea water inundation (b) and Permafrost (c).....	147
Fig. 58	Distribution of Cs-135 in the model area after 1 million years for stationary climate conditions (a), for Sea water inundation (b) and Permafrost (c).....	148
Fig. 59	Dose conversion factors of several radionuclides for different climate states (geosphere-biosphere interface: well).....	150
Fig. 60	GBI “well“: Dose conversion factors for selected radionuclides and different climate states	151
Fig. 61	Principal sketch of the non-isothermal CIEMAT test; from /KRO 08/.	158
Fig. 62	Relation of primary and secondary variables in the non-isothermal vapour flow model; from /KRO 08/.	160

- Fig. 63 Measured and calculated relative humidity data for phase 2 –
water uptake; close-up (left) and full data set (right); from /KRO 08/. 161
- Fig. 64 Measurements and model results for the Canister Retrieval Test;
axial distance r in the legend indicates distance to symmetry axis. 163

List of Tables

Tab. 1	Elements (E), components (K) and potential associated aspects of a safety case for a geological repository (after /NEA 08b/)	5
Tab. 2	Scenario: Abandoned Borehole Penetration of the Repository; Peak doses and main contributors for different waste types /AND 05/	29
Tab. 3	Comparative rating of the relevance of different human intrusion scenarios and geosystems (from /SKR 05/)	40
Tab. 4	Isotopes of primary interest for the disposal of spent fuel and high-level vitrified waste (shown with the symbol ■)	53
Tab. 5	Task evaluation table for the salt-specific tasks	73
Tab. 6	Thickness of the EDZ and the zone of de-saturation for the tunnel and the two galleries at the Tournemire site /REJ 06/	115
Tab. 7	Compilation of hydraulic data for three claystone formations.	125
Tab. 8	Inventory distribution of C-14 forms on UO ₂ matrix and metal parts and instant release fractions	131

**Gesellschaft für Anlagen-
und Reaktorsicherheit
(GRS) mbH**

Schwertnergasse 1
50667 Köln
Telefon +49 221 2068-0
Telefax +49 221 2068-888

Forschungsinstitute
85748 Garching b. München
Telefon +49 89 32004-0
Telefax +49 89 32004-300

Kurfürstendamm 200
10719 Berlin
Telefon +49 30 88589-0
Telefax +49 30 88589-111

Theodor-Heuss-Straße 4
38122 Braunschweig
Telefon +49 531 8012-0
Telefax +49 531 8012-200

www.grs.de